

## System manual heatcon! System





heatcon! System  
System manual  
Edition: 11.2024  
Art: 0450000547-2448

The heatcon! system is constantly being further developed. Therefore, the documentation develops dynamically. Please check on <https://ebv-gmbh.eu/downloads/?lang=en> for a newer version of the heatcon! system manual is available.



We reserve the right to make technical and content changes to this document at all times without prior notice.

EbV assumes no responsibility for any errors or omissions in this document.

All rights to this document and the contained themes and figures are reserved. Reproduction, disclosure to third parties or use of the content, either in whole or in part, is forbidden without the prior written consent of EbV.

Copyright© 2024 EbV - Elektronikbau- und Vertriebs GmbH  
All rights reserved

# 1 Table of contents

<b>1</b>	<b>Table of contents</b>	<b>4</b>
<b>2</b>	<b>List of abbreviations</b>	<b>8</b>
<b>3</b>	<b>Safety</b>	<b>10</b>
3.1	General Information	10
3.2	Structure of the warning instructions	10
3.3	Intended use	10
3.4	Personnel qualifications	11
3.5	Safety instructions for operating	11
3.5.1	Hazards due to water temperatures > 60 °C	11
3.6	Warranty conditions	11
<b>4</b>	<b>System description</b>	<b>12</b>
4.1	General Information	12
4.1.1	System overview	15
4.2	System expansion	16
4.3	System overview	17
<b>5</b>	<b>Components</b>	<b>18</b>
5.1	heatcon! MMI	18
5.2	heatcon! EC	19
5.2.1	Device versions	20

5.3	heatcon! EM 100 / heatcon! EM 101	22
5.4	heatcon! EM 110 – OT	24
5.5	heatcon! GBA	28
5.6	heatcon! RC 130	29
5.7	Single room control heatapp!	30
<b>6</b>	<b>Operation and extended configuration</b>	<b>31</b>
6.1.1	Menu overview	47
6.1.2	MMI Basic display konfigurieren	48
6.1.3	Speed button functions MMI	49
<b>7</b>	<b>Initial operation</b>	<b>61</b>
7.1	Conditions and requirements	61
7.2	Inbetriebnahme mit dem Einrichtungsassistent	61
7.3	Update heatcon! EC	61
7.3.1	Installation Updates via USB Stick	62
7.3.2	Assignment of the inputs and outputs	63
7.3.3	Setup wizard in heatcon! MMI and web browser	68
7.4	Single room control heatapp!	79
<b>8</b>	<b>Parameter description</b>	<b>80</b>
8.1	Calling the expert menu	80
8.1.1	heatcon MMI	80
8.2	heatcon! MMI	82
8.3	Menu – System	84
8.4	Menu – Domestic hot water (1) (2)	85

8.5	Menu – Room 1 ... n / Room group 1 ... n.....	91
8.6	Menu – Heating circuit .....	97
8.7	Menu - Total flow .....	101
8.8	Menu – Cascade .....	103
8.9	Menu – Energy generator -1 or 2.....	105
8.10	Menu – Heating buffer (1) (2) .....	112
8.11	Menu – Solar .....	115
8.12	Menu – Solid.....	119
8.13	Menu – Return flow.....	122
8.14	Menu – Extras.....	124
8.15	Menu – Configuration .....	126
8.15.1	Menu – Information .....	126
8.15.2	Menu – function .....	126
8.15.3	Menu – Hardware.....	138
<b>9</b>	<b>Function descriptions.....</b>	<b>141</b>
9.1	General controller functions .....	141
9.1.1	Outside temperature measurement and processing .....	141
9.1.2	Frost protection function .....	143
9.1.3	Anti-lock function .....	144
9.1.4	Pump-function.....	145
9.1.5	Heat balancing.....	150
9.2	Energy/heat generation.....	152
9.2.1	Energy manager.....	152

9.2.2	Energy generator -types .....	156
9.2.3	General Energy generator functions .....	164
9.2.4	Heating / Domestic hot water .....	166
9.2.5	Boiler Pump modulating start protection .....	166
9.2.6	Full load shutdown – minimum charge control.....	167
9.2.7	Energy generator pums .....	167
9.2.8	Return flow hold-up .....	168
9.3	Energy generator -Cascade.....	170
9.3.1	Cascade parameterization.....	172
9.3.2	Information .....	172
9.3.3	Basic settings .....	173
9.3.4	Cascade concept.....	174
9.3.5	Requirement management .....	175
9.3.6	Switching behavior .....	175
9.3.7	Switching sequence / priority control .....	176
9.3.8	Main supply regulation.....	178
9.4	Heating circuit -functions .....	179
9.4.1	Heating function.....	179
9.4.2	Heating circuit Pump .....	180
9.4.3	Mixing valve control .....	180
9.4.4	Return flow limitation .....	185
9.4.5	Cooling methods of the heatcon! System .....	185
9.4.6	Parameter settings passive cooling mode.....	185

9.4.7	Passive cooling mode .....	186
9.4.8	Cooling curve .....	187
9.4.9	Calculating room Setpoint temperature.....	188
9.4.10	Connection room Setpoint temperature ⇔ flow temperature .....	189
9.4.11	Functionality of room unit.....	191
9.4.12	Active cooling .....	191
9.4.13	Parameter settings active cooling mode .....	192
9.4.14	Cooling (app) .....	194
9.4.15	Manual cooling .....	195
9.4.16	Operating manual room cooling.....	196
9.5	<i>Room groups and rooms.....</i>	<i>198</i>
9.5.1	Room temperatures .....	199
9.5.2	Room temperature control .....	200
9.5.3	Weather-guided heating operation (outside temperature control) ....	201
9.5.4	Switch on optimization .....	205
9.5.5	Screed drying function.....	207
9.5.6	Room blocking.....	213
9.6	<i>Domestic hot water-functions .....</i>	<i>214</i>
9.6.1	Hot water control via the storage sensor .....	214
9.6.2	Hot water control via an external thermostat.....	216
9.6.3	Hot water operation .....	216
9.6.4	Legionella protection function .....	218
9.6.5	Shutdown type .....	218

9.6.6	Hot water charging via Heating usage.....	219
9.6.7	DHW circulation pump .....	220
9.6.8	Hot water tank 2.....	221
9.7	<i>Heating buffer functions.....</i>	<i>222</i>
9.7.1	Heating buffer variants and components.....	223
9.7.2	Function description – charge control.....	225
9.7.3	Function description – discharge control .....	228
9.7.4	Hydraulic examples – heating buffer function .....	230
9.8	<i>Differential control (solar, solid fuel, and general differential control) .....</i>	<i>244</i>
9.8.1	Differential control solar – double buffer system with charge valve switchover	248
9.8.2	Differential control solar – double collector array .....	250
9.8.3	Differential control solar – double collector system and double buffer system with charge valve switchover.....	252
9.8.4	Pump – differential control .....	253
9.8.5	Heat balance – differential control .....	253
9.9	<i>External Request.....</i>	<i>254</i>
9.9.1	Setpoint connection via 0-10V .....	254
9.9.2	Request contact heating buffer.....	254
9.9.3	Switching contact .....	254
9.10	<i>Thermostat.....</i>	<i>256</i>
<b>10</b>	<b><i>Troubleshooting .....</i></b>	<b><i>257</i></b>
10.1	<i>Display of fault messages.....</i>	<i>257</i>
10.2	<i>Fault messages of connected burner control systems.....</i>	<i>261</i>

10.3	<i>heatcon! Error codes</i> .....	262
10.4	<i>Fehlermeldungen</i> .....	264
<b>11</b>	<b>Accessories</b> .....	<b>291</b>
11.1	<i>Outside sensor Outside temperature</i> .....	291
11.2	<i>Immersion sensor KVT</i> .....	292
11.3	<i>Immersion sensor PT1000</i> .....	293
11.4	<i>Flow sensor VF</i> .....	294
11.5	<i>heatcon! Sensor-Set</i> .....	295
11.6	<i>heatcon! Device bus cable</i> .....	295
<b>12</b>	<b>Technical data</b> .....	<b>296</b>
12.1	<i>heatcon! EC</i> .....	296
12.2	<i>heatcon! EM 100</i> .....	299
12.3	<i>heatcon! EM 101</i> .....	300
12.4	<i>heatcon! EM 110 – OT</i> .....	301
12.5	<i>heatcon! EM – GBA</i> .....	302
12.6	<i>Cable lengths and cross-sections</i> .....	303
12.7	<i>Resistance values for sensors of type KTY20</i> .....	304
12.8	<i>Resistance values for sensors of type PT1000</i> .....	304
<b>13</b>	<b>Appendix</b> .....	<b>305</b>
13.1	<i>Hydraulic examples</i> .....	305
13.1.1	Single or two-stage GEN with unmixed heating circuit and DHW .....	305

13.1.2	Single or two-stage H-GEN with one unmixed heating circuit and DHW separate circuit with a main Pump (HP) as a feed Pump .....	308
13.1.3	Single or two-stage GEN with unmixed heating circuit, DHW and circulation pump	311
13.1.4	Single or two-stage H-GEN with one unmixed, one mixed heating circuit and DHW	314
13.1.5	Single or two-stage H-GEN with one unmixed, two mixed heating circuits and DHW	317
13.1.6	Buffer loading control for heating circuit and DHW Requests .....	319
13.1.7	Buffer - discharge control to HC and DHW with solid and solar .....	321
13.2	<i>heatcon! EC connections for print and notes</i> .....	324
13.3	<i>Switching times table</i> .....	325
13.4	<i>Login data</i> .....	327
13.5	<i>Access data lost - Forgotten password</i> .....	328
13.5.1	Forgotten password function .....	328
13.5.2	Reset without access data .....	333

## 2 List of abbreviations

A10VP	Output 0-10V / PWM
ABS	Setback mode
ADR	Adress switch
AF	Outside sensor (OS)
AF2	Outside sensor 2 (OS2)
AGF	Exhaust gas sensor
ARS	Normally open relay output (ONOR)
ARSP	Normally open potential free relay output (ONOPR)
AT	Outside temperature
BCP	buffer charging pump
BDP	buffer discharge pump
BDV	buffer discharge valve
BE	Operator /Owner
BLZ	GEN / burner runtime (BRC)
BR1	Energy generator / burner stage 1
BR2 AUF	Energy generator / burner stage 2 ON
BR2 ZU	Energy generator / burner stage 2 OFF
BRSP	Burner block
BULP	Buffer load pump
BUS	System data bus
BUSFS	Solid fuel buffer sensor
BZ	GEN / burner runtime (BRC)
CBS	collector buffer sensor
CEST	Central European Summer Time
CF	Common flow
CFS	Collector flow sensor
CHP	Feed pump
CIP	circulation pump
CP	Condenser pump / HP main pump
CPS	DHW circulation pump sensor
DHC	Diverter valve heating circuit (heating/cooling)
DHCP	Dynamik Host Configuration Protocol
DHW	Hot water
DHWDI	Hot water diverter valve (DHWDI)
DIF1PF	Dif1 Buffer sensor

DIF1SOP	DIF1 Solar pump
DIF1VF	DIF1 Flow sensor
DIFF	Differential control
DP	delivery pump
DVV	Diverter valve
E/A	Input/Output I/O
ECO	Eco mode
EEZ	Energy generator
EFI	Sensor/pulse input (ISP)
EHWW	Electric heater hot water
EI	Pulse input
ELF	Discharge valve sensor heating buffer
ELH	DHW electrical heating element
EM	Extension module
EO	Opto-coupler input (IOC)
FGS	ExhOfft gas sensor
FKF	Solid boiler sensor
FMI	Fault message input
FPF	Solid buffer sensor
FS	Flow sensor (FS)
FSP	Solid fuel pump
GB	Device bus
GBA	Device bus adapter
GEN	Energy generator (GEN)
h2B	heatcon! 2-wire bus
HBD	Hydraulic buffer discharge
HK	Heating circuit (HC)
HCP	heating circuit pump
HF	Expert
HK1 AUF	Heating circuit 1 valve open (HC1 OPEN)
HK1 P	Heating circuit 1 Pump
HK1 ZU	Heating circuit 1 valve closed (HC1 CLOSED)
HK2AUF	Heating circuit 2 valve open (HC2 OPEN)
HK2P	Heating circuit 2 Pump
HK2ZU	Heating circuit 2 valve closed (HC2 CLOSED)
HK3P	Heating circuit 3 Pump
HP	Heat buffer (HB)

HPE	Hydraulic buffer discharge (HBD)
HPP	Heating buffer pump
HTM	Heat quantity
IHDHW	Electrical heating usage hot water
KKP	Boiler circuit pump (BCP)
KSPF	Collector buffer sensor
KVLF	Collector flow sensor
LAN	Lokal Area Network
MESZ	Central European Summer Time (CEST)
MMI	Control unit with display
MOD	Modulation
OEM	OEM manufacturer
OHC	Burner runtime
OS	Outside sensor
P	Pump
PEP	Buffer storage loading pump
PEV	Buffer storage unloading pump
PER	Parallel (H-GEN) GEN release
PF	Buffer storage sensor (BS)
PF1	Buffer storage sensor (BS) 1
PF2	Buffer storage sensor (BS) 2
PI Regler	Proportional-integral controller
PLP	Buffer charge pump
PP	Primary pump
PWM	Pulse width modulation
PWF	Parallel energy generator activation
RC	Room Control
RED	Reduce mode
RF	Room sensor (RS)
RLB	Return flow limit
RLF	Return sensor
RLH	Return flow control/increase
S	Sensor
SBS	solid fuel boiler sensor
SBUS	Solar collector buffer storage sensor
SCFS	Storage charging flow sensor
SCP	Storage charging pump



SCV	storage charging valve
SF	DHW sensor
SFP	solid fuel pump
SLP	Storage charging pump
SLV	Solar charge valve
SLVF	Solar charge valve sensor (SLVS)
SoCFS	Solar collector flow sensor
SMA	Fault signal output
SME	Fault signal input
SOP	Solar circuit pump
SoCFS	Solar collector flow sensor
SS	Storage sensor
STL	Safety temperature limiter
STB	Safety temperature limiter
SVL	Sum flow
SVLF	Sum flow sensor
UHK	Diverter valve HC (heating/cooling)
ULV	Diverter valve
UWW	Hot water diverter valve (DHWDI)
VF (VLF)	Flow sensor (FS)
VF 1	Flow sensor (FS) 1
VF2	Flow sensor (FS) 2
WEZ	Heat generator (oil/gas) (H-GEN)
WF	Heat generator sensor (boiler sensor)
WMZ	Heat meter
WW	Hot water
ZAF	Forced drainage
ZKP	Circulation pump
ZKPF	Circulation pump sensor
ZUP	DHW circulation pump

## 3 Safety

### 3.1 General Information

Any person charged with working on the device or system, must have read and understood this manual, especially the chapter on "Safety". Instruction may be necessary, dependent on the professional qualifications of the persons in question. The relevant accident prevention regulations and other generally accepted safety regulations must be complied with.

### 3.2 Structure of the warning instructions

Explanation of the warning instructions in this manual:

#### **DANGER**

Brief description of the hazard

The signal word **DANGER** indicates a directly threatening hazard. Non-observation leads to severe injuries or death.

#### **WARNING**

Brief description of the hazard

The signal word **WARNING** indicates a possible hazard. Non-observation may result in severe injuries or death.

#### **CAUTION**

Brief description of the hazard

The signal word **CAUTION** indicates a possible hazard. Non-observation can result in slight or moderate injuries.

#### **ATTENTION**

Brief description

The signal word **Attention** indicates possible property damage. Non-observation can lead to damage to the device or plant.

#### **NOTE**

The signal word **NOTE** indicates further information about the device or its use.

### 3.3 Intended use

The device or system is intended solely for the use described in the section "System", on page 12 with supplied and approved components. Any other use is classified as an improper use. The manufacturer shall not be liable for any damage resulting from this. The user/operator is solely responsible for the risk. Observance of the information contained in the operating instructions forms part of the intended use. Hazards can arise from the system if it is not used as intended.

### 3.4 Personnel qualifications

The electrical installation, initial operation and servicing of the device may only be performed by qualified electrical technicians who have been authorised by the operator. The technicians must have read and understood these operating instructions and follow their procedures.

Requirements to be met by a qualified electrical technician:

- Knowledge of general and special safety and accident prevention regulations.
- Knowledge of the relevant electrical regulations (e.g. DIN VDE 0100 Part 600, DIN VDE 0100-722) plus the relevant national regulations.
- Ability to identify risks and avoid possible hazards.

### 3.5 Safety instructions for operating

#### 3.5.1 Hazards due to water temperatures > 60 °C

During operation, there is a risk of scalding at all heating system hot water outlets in the following cases because of hot water temperatures > 60°C:

- Automatic anti-legionella system

If the automatic anti-legionella system is activated, the domestic hot water will automatically be heated up to a temperature of 65 °C in order to kill legionella bacteria in the hot water system on the selected day and at the selected time.

- Manual mode/ Emission measurement

In the manual mode / emission measurement mode the domestic hot water can be heated up to the maximum possible boiler temperature because the burner and all Pumps are switched on and the valves will be completely opened.

Heating and domestic hot water are not temperature controlled in these modes. These modes are especially used by the emission measurement specialist or by the installer in case the controller is defective.

However, the high water temperatures can be avoided if the boiler thermostat is adjusted to a max. boiler temperature of 60 °C.

Observe the following points to prevent scalding:

- Inform all users of the danger.
- Mix enough cold water or switch the domestic hot water loading Pump off manually (if there is a switch at the Pump).

### 3.6 Warranty conditions

Improper use, non-observation of these instructions, use of inadequately qualified personnel and independent changes exclude any liability on the part of the manufacturer for the resulting damage. The manufacturer's warranty becomes void.

#### **ATTENTION**

Impairment of device function if incorrect spare parts are used!

If unauthorised parts are used correct functioning is not assured. Use spare parts authorised by customer service.

## 4 System description

### 4.1 General Information

The heatcon! system is designed exclusively for the control of hot water heating and district heating systems including domestic hot water control. These systems should not exceed a flow temperature of 120 °C.

The heatcon! system consists of the following components:

#### **heatcon! EC**

The EC base controller is the main control unit and is installed in or on the energy generator.

#### **heatcon! MMI**

The MMI is a control unit for connecting to the EbV-system bus for operation of the whole system without an Internet browser.

#### **heatcon! RC 130**

The RC room station can be used as a remote-control unit for room groups via the wired h2B bus.

#### **heatcon! EM 100 / 101**

The EM Extension modulee serves as an extension on the inputs and outputs of an EC-Base controller within the system.

#### **heatcon! EM – GBA**

The heatcon! EM - GBA becomes the extended wiring of the heatcon! cascade is used.

#### **heatcon! EM 110 – OT**

The heatcon! EM 110- OT allows the OpenTherm cascade to be connected to a heatcon! EC 1351 pro.

#### **heatapp! App**

The app is installed on mobile devices such as smartphones or tablets (iOS or Android) and is used to control heatcon! systems.

The app is currently available in English, German, Dutch, French and Italian. If the tablet or smartphone is set to “English” the English app displays automatically.

### heatapp! sense-wire (wired room sensor)

heatapp! sense-wire is a wire is a wired temperature sensor for measuring the room temperature. The device is fitted on the wall and connected to the heatcon!. heatapp! sense-wire is used for control of a heating circuit based on the reference room principle.

### heatapp! gateway

heatapp! gateway is the main wireless interface of the system. heatapp! gateway receives and sends information to allheatapp! wireless components, e.g. for control of the radiators (heatapp! drive), anderfloor heating system (heatapp! floor) and for room temperature measurement (heatapp! sense) and to all other heatapp! wireless components, functioning as message interface for the heatcon! System.

In this way genuine single room heat regulation with demand Requests is possible in accordance with EN 1523.

### heatapp! single room control

To enable single room control, heatcon! requires system components for measurement and control of the actual temperature.

To do so, the heatcon! system operates the heatapp! wireless components. These communicate via Z-wave wireless with the heatapp! gateway.

The components are selected dependent on the installed heating system.

A few examples:

Heating system	heatapp! radio modulees	Description
Wall radiator	heatapp! drive	Wireless actuator for radiators Temperature measurement and temperature control is performed by the heatapp! drive.
Anderfloor heating system	heatapp! floor	Zone controllers for anderfloor heating systems Temperature measurement via heatapp! sense Temperature control via thermo-electric actuators connected to heatapp! floor
Electrical heat source (e.g. fan heater, infrared heating, etc.)	heatapp! single floor	Wireless switch for 230 V consumers Temperature measurement via heatapp! sense Temperature control via heatapp! single floor

To ensure reliable wireless coverage, heatapp! repeaters may be required.

heatapp! single room control is undergoing continuous development. Therefore, at this point, only a few typical examples are listed.

You can see the full range of heatapp! components under <https://heatapp.de/wie-funktioniert/>.

### **heatapp! connect (remote access)**

heatapp! connect must be activated in the setup wizard of the heatcon! system, if the heating system is to be operated from anywhere. heatapp! connect is a web server and creates the connection when you access your heating with the app while on the way.

heatapp! connect does not save any data. All data, access data and passwords are stored at home in the heatcon! EC and are only accessible to authorised users after login. This concept offers maximum data security.

### **heatapp! Installations-Kit for the installer**

The heatcon! system is set up for initial operation using the heatapp! installation kit. It contains a heatapp! USB-LAN adapter and a LAN cable. The installation kit is used to connect the heatcon! EC and the heatapp! gateway with the PC/laptop for initial configuration, so that the user interface can be called in the Internet browser.

### **ALTERNATIVE:**

heatapp! Installations-Stick for the installer

The heatcon! system is set up for initial operation using the heatapp! installation stick.

The heatapp! installation stick creates its own Wi-Fi network for connecting to the heatcon! EC and the heatapp! gateway.

The heatapp! installation stick must be removed after the configuration.

#### 4.1.1 System overview

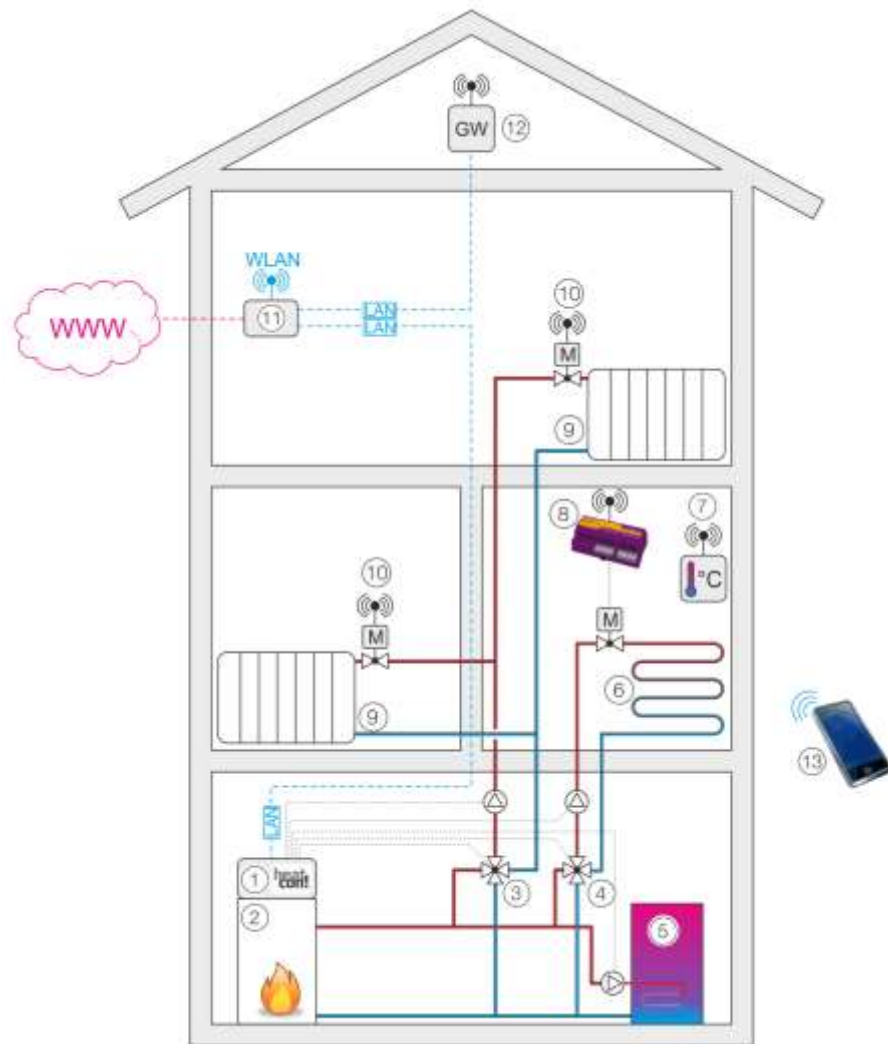

- 1 heatcon! EC
- 2 Energy generator
- 3 Mixer heating circuit 1
- 4 Mixer heating circuit 2 (Anderfloor heating)
- 5 DHW Storage
- 6 Anderfloor heating system (FBH)
- 7 heatapp! sense
- 8 heatapp! floor
- 9 Radiator
- 10 heatapp! drive
- 11 Wi-Fi-Router (customer-provided)
- 12 heatapp! Gateway
- 13 Smartphone (Mobilephone) / Tablet with heatapp! App

Fig. 1: System overview (example)

## 4.2 System expansion

The heatcon! system can be expanded with the following components:

- Up to 3 heatcon! EC basic controllers.
- Up to 6 heatcon! EM Extension modules (maximum of two Extension modules per heatcon! EC basic controller).
- Up to 4 heatcon! EM 110 - OT Extension modules on every heatcon! EC 1351 pro.
- 1 heatcon! EM - GBA Extension module for extended wiring of the heatcon! Cascade.
- heatcon! RC 130 room station at every heating circuit.
- Expandable with heatapp! wireless single room control for up to 24 rooms.

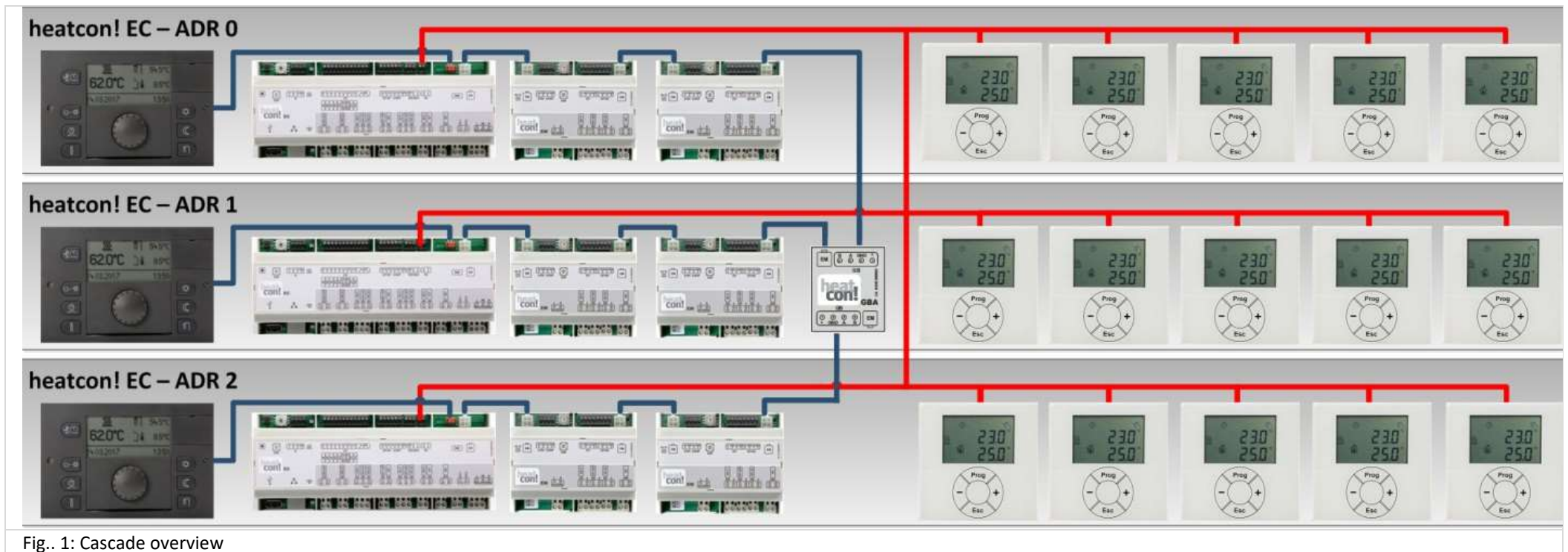
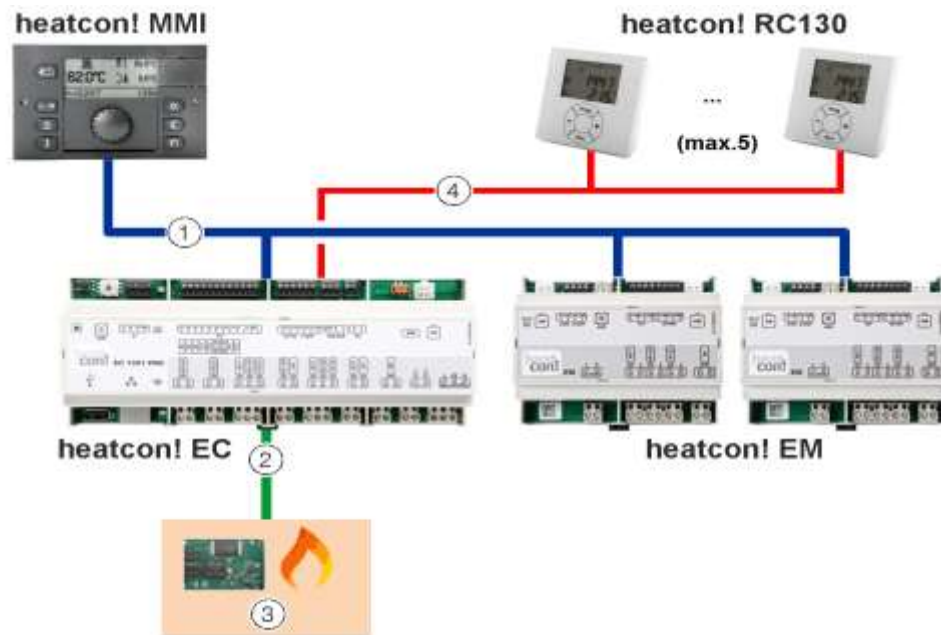

Fig.. 1: Cascade overview



### 4.3 System overview

heatcon! with room station heatcon! RC



heatcon! with single room control heatapp!

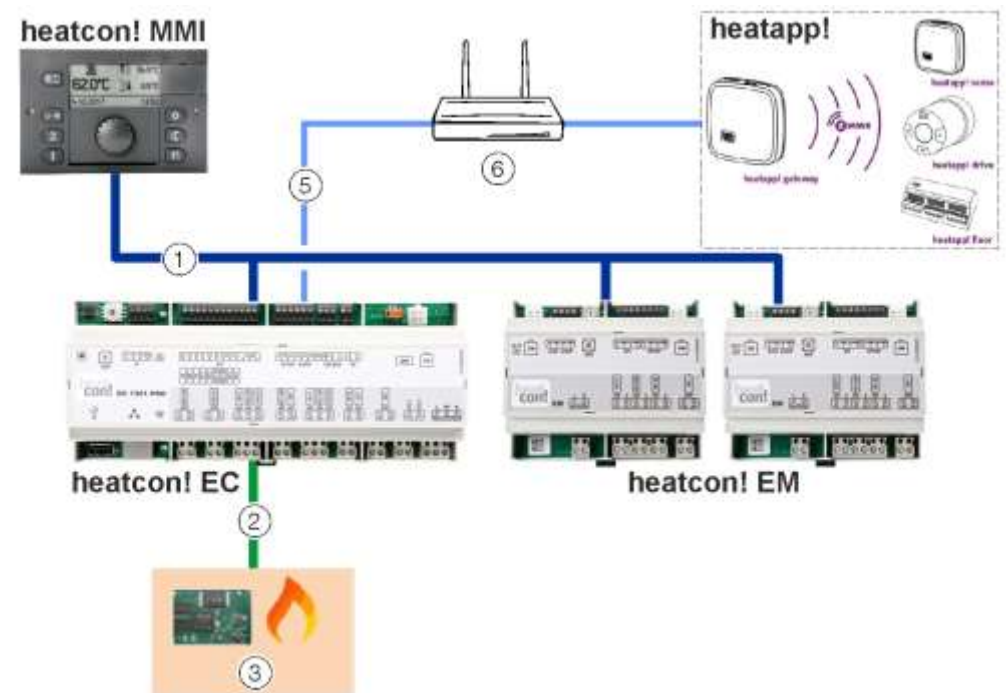

Fig. 2: System overview heatcon!

- 1 EbV system bus
- 2 GEN-Bus (Energy generator)
- 3 Energy generator

- 4 h2B-bus
- 5 Network connection (Ethernet)
- 6 Router

## 5 Components

### 5.1 heatcon! MMI

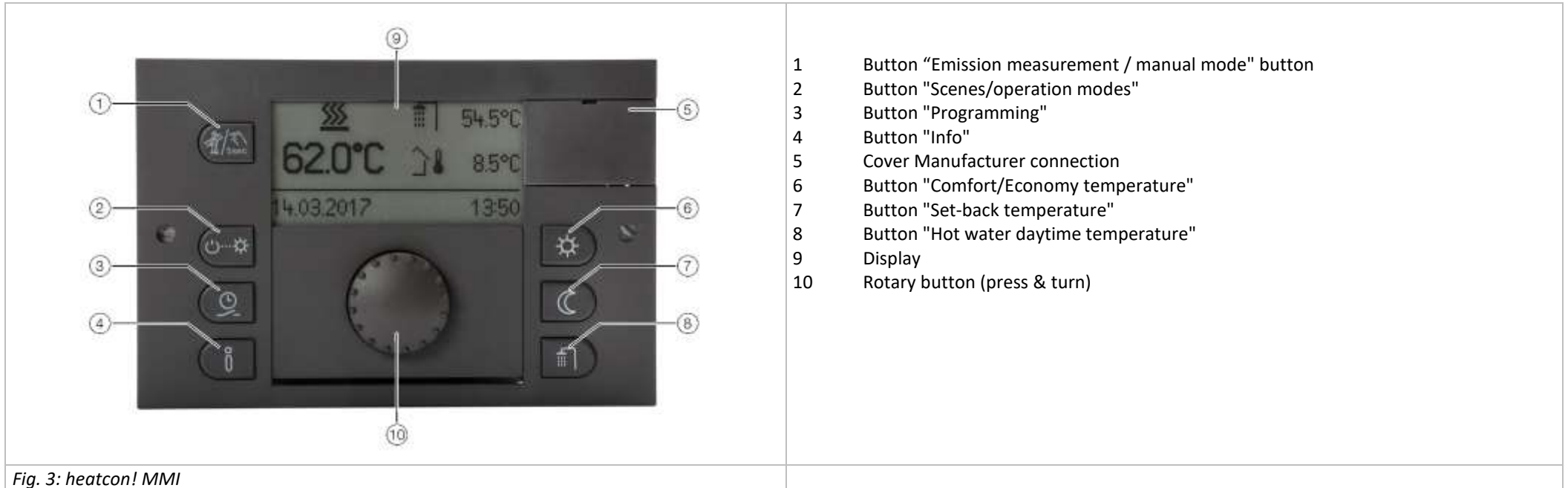

Fig. 3: heatcon! MMI

The heatcon! MMI is the control unit for the heatcon! System for operation without an Internet browser. The buttons are used to call the corresponding menus. Navigation through the menus and setting of values is performed using the rotary knob. For more information on operation, see chapter "Operation", on page 27. At each heatcon! EC a heatcon! MMI can be connected.

The assignment is made directly to the desired heatcon! EC.

Connect to:	Address of EC:	MMI-No.:	Operatin on:
EC 1	ADR 0	MMI 1	heatcon-0
EC 2	ADR 1	MMI 2	heatcon-1
EC 3	ADR 2	MMI 3	heatcon-2

#### NOTE

The setup of the heatcon! MMIs must be carried out one after the another, as the address assignment in the bus system is automatic.

## 5.2 heatcon! EC

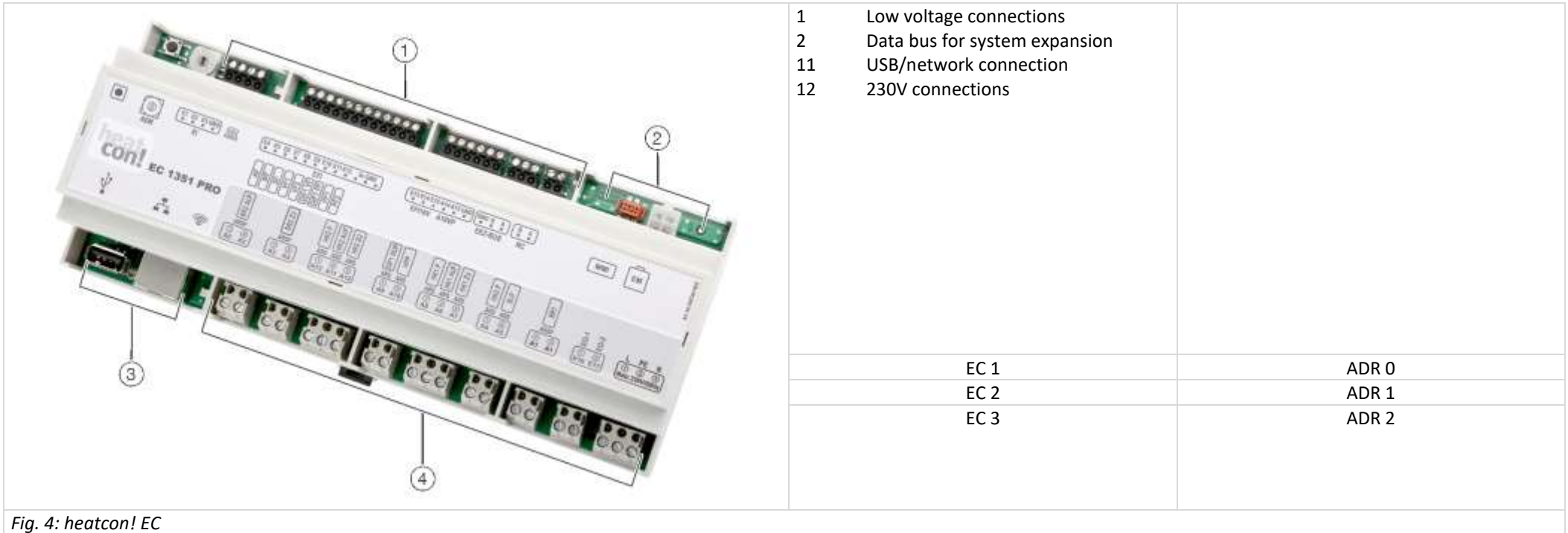

Fig. 4: heatcon! EC

The heatcon! EC is the central control and regulation unit and is installed in or on the energy generator.

All components (Pumps, valves, sensors) of the heating system are connected and controlled here.

The heatcon! EC is connected to the energy generator. The heatcon! EC offers various options here. A direct communication option is available in the heatcon! EC 1321 Pro via an OpenTherm® interface, in the case of a heatcon! 1351 Pro via an RS 485 interface. The other control options of the heatcon! EC to the energy generator are the classic potential-free relay contact or 0-10V control.

Additional data bus connections are available for system expansion.

The heatcon! EC can be used as a mini-cascade. With one heatcon! EC can be used to control and regulate two energy generators in a cascade network.

In the heatcon! EC, the addresses 0 ... 2 can be used with the rotary coding switch. This allows a maximum of 6 energy generators to be connected when using the mini-cascade.

Via the RS 485 communication interface of the heatcon! EC 1351 Pro, up to 8 OpenTherm generators can be connected via the RS 485 communication interface of the heatcon! EM 110 additional modules can be used to cascade up to 8 OpenTherm®-capable automatic units to one heatcon! EC can be cascaded. This means that when using 3 heatcon! EC, a maximum of 24 OpenTherm® capable automats can be cascaded.

### NOTE

Invalid addresses 3... 15 are interpreted as address setting 0!

### 5.2.1 Device versions

The *heatcon EC* is available in different versions. The versions differ in the available functions.

Inputs/outputs/connections	EC1321 PRO	EC1351 PRO	EM 100/101
230V/50Hz connection	1	1	1
LAN interface	1	1	-
USB interface	1	1	-
h2 bus (connection <i>heatcon RC</i> )	1	1	-
H-GEN bus (OpenTherm)	1	-	-
H-GEN bus (RS485)	-	1	-
Device bus 1 (MMI)	1	1	-
Device bus 2 (EM)	1	1	2
Pulse inputs (PI)	3	3	-
Sensor/pulse inputs (ISP)	9	9	2
Sensor/pulse/0-10V inputs (ISP10V)	3	3	2
Opto-coupler inputs (IOC, 230V)	2	2	-
Relay output, normally open potential-free (ONOPR)	3	3	1
Relay output, normally open (ONOR)	10	10	3
0-10V- / PWM output (A10VP)	2	2	2

Functions	EC1321 PRO	EC1351 PRO	EM 100/101
Energy generator single stage	2	2	-
Energy generator two stage/modulating OFF/ON	1	1	-
Energy generator over 0-10V	2	2	-
Energy generator control system actuation	1	1	-
Hot water function	1	1	-
Heating buffer function	1	1	-
Heating circuit 1 (mixer, unmixed circuit)	1	1	-
Heating circuit 2 (mixer, unmixed circuit)	1	1	-
Heating circuit 3 (unmixed circuit)	1	1	-
Heating circuit 4 (mixer, unmixed circuit)	-	-	1
Heating circuit5 (mixer, unmixed circuit)	-	-	(1) zweites EM
Differential control 1	1	1	-
Differential control 2	1	1	-
Differential control 3	1	1	-
Room operation via <i>heatcon! RC</i>	X	X	X
Operation via <i>heatapp! App</i>	X	X	X
Initial setup via PC	X	X	X

### 5.3 heatcon! EM 100 / heatcon! EM 101

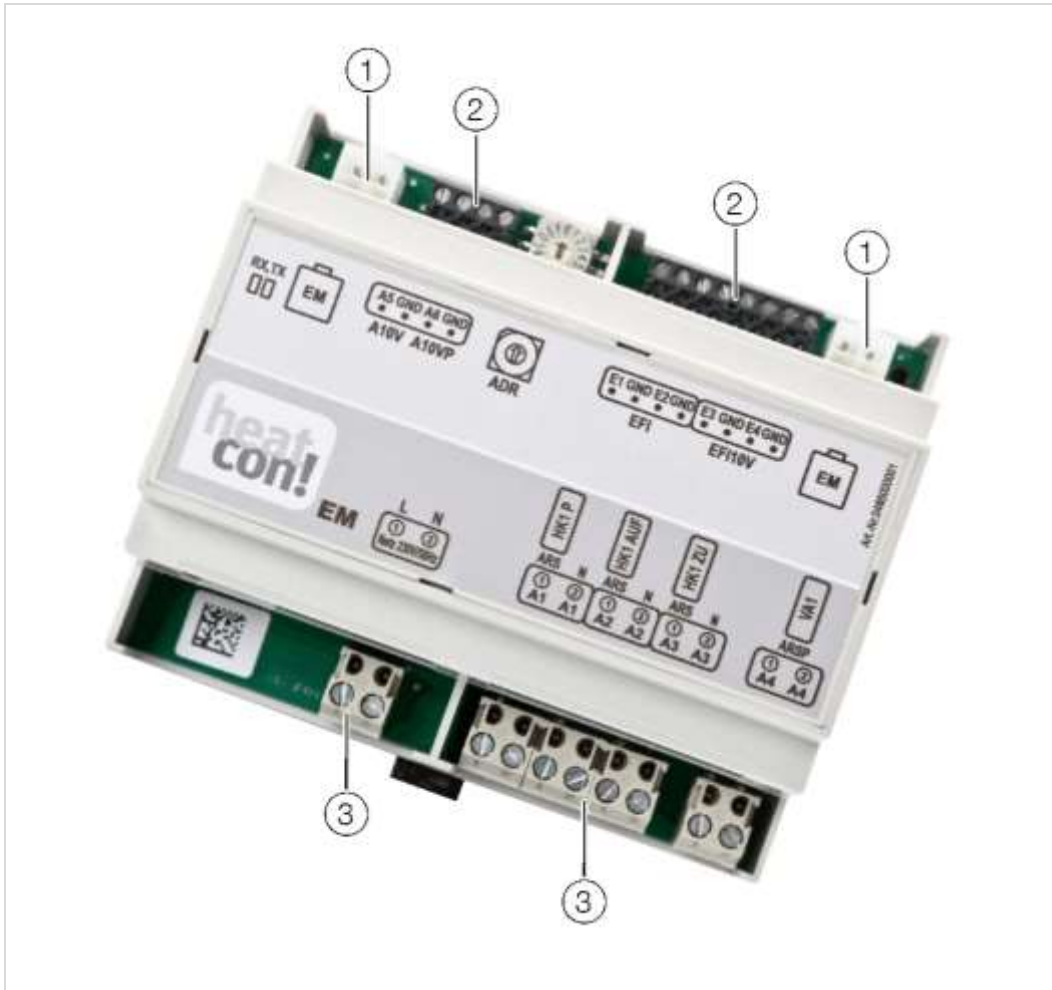

Fig. 5: heatcon! EM 100

- 1 EbV device bus
- 3 230V connections

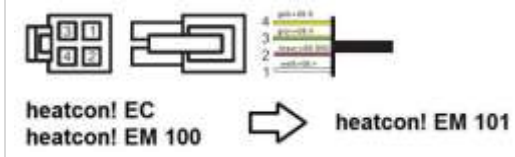

Fig. 6: heatcon! EM 101

- 2 Low voltage connections

- 4 yellow = GB: B
- 3 green = GB: A
- 2 brown = GB: GND
- 1 white = GB: +

The heatcon! EM is an expansion for the inputs and outputs of a heatcon! EC inside the system. The heatcon! EM is offered in two versions: The EM 100 for top hat rail mounting and the EM 101 for wall mounting.

Here other components (Pumps, valves, sensors) of the heating system are connected and controlled.

The heatcon! EM is connected via the EbV-device bus with the heatcon! EC. Every heatcon! EC can be extended with a maximum of 2 heatcon EM.

**NOTE**

---

Addresses 6 .... 9 and A ... F on the rotary coding switch have no function!

---

By using up to 2 heatcon! EM, the heatcon! EC

- up to two additional heating circuits
- up to four 0-10V/PWM outputs
- up to two variable potential-free outputs
- can be extended.

The address settings on the EM have the following default functions:

Connect at:	Adress EC:	EM1-No.:	Adress EM:	Function
EC 1	ADR 0	EM1-A	ADR 0	e.g. heating circuit extension 4 on EC 1
EC 1	ADR 0	EM1-B	ADR 1	e.g. heating circuit extension 5 on EC 1
EC 2	ADR 1	EM1-A	ADR 2	e.g. heating circuit extension 4 on EC 2
EC 2	ADR 1	EM1-B	ADR 3	e.g. heating circuit extension 5 on EC 2
EC 3	ADR 2	EM1-A	ADR 4	e.g. heating circuit extension 4 on EC 3
EC 3	ADR 2	EM1-B	ADR 5	e.g. heating circuit extension 5 on EC 3

## 5.4 heatcon! EM 110 – OT

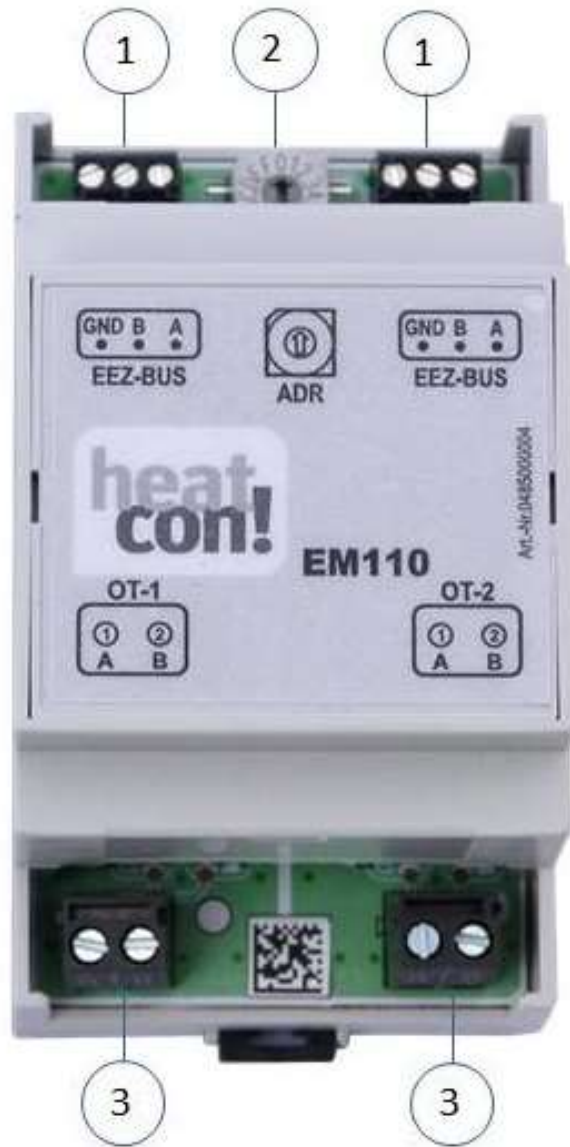

- 1 GEN Bus (Energy generator bus 485)
- 2 Adress switch
- 3 OpenTherm Bus

Fig. 7: heatcon! EM 110 - OT



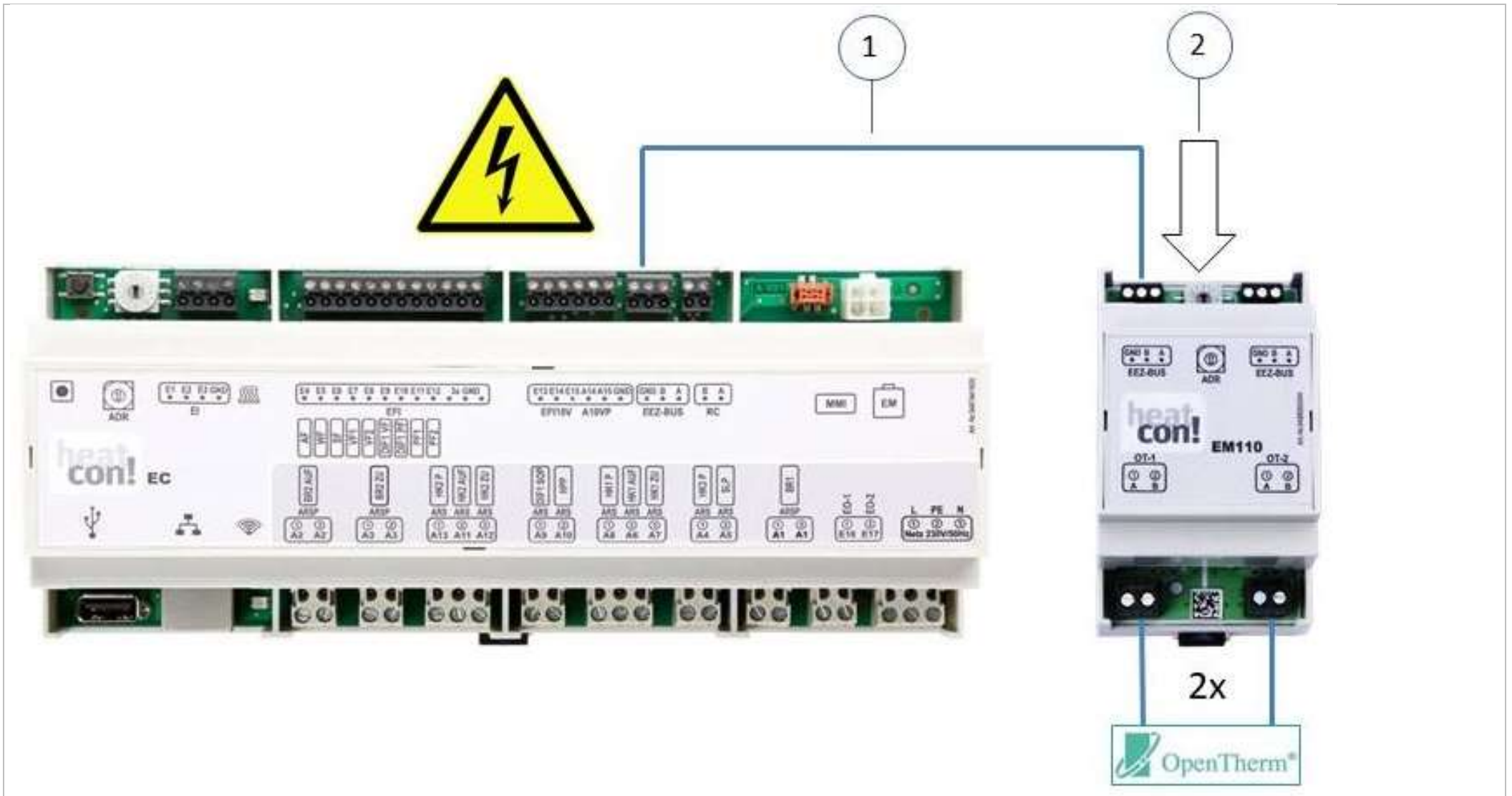

Fig. 8: Connection heatcon! EM 110 - OT to the heatcon! EC

1	GEN-Bus
2	Adress-switch

Every heatcon! EM 110-OT offers the possibility to connect two OpenTherm machines. On a heatcon! EC 1351pro can connect up to four heatcon! EM 110-OT.

## Addressing

The addressing takes place at the heatcon! EM 110 - OT

EC	Addressing EM 110	No.OT	Address Assignment Automat
EC1	Address 0	OT1 OT2	Adr. 0 Adr. 1
EC1	Address 1	OT3 OT4	Adr. 2 Adr. 3
EC1	Address 2	OT5 OT6	Adr. 4 Adr. 5
EC1	Address 3	OT7 OT8	Adr. 6 Adr. 7
EC2	Address 0	OT9 OT10	Adr. 0 Adr. 1
EC2	Address 1	OT11 OT12	Adr. 2 Adr. 3
EC2	Address 2	OT13 OT14	Adr. 4 Adr. 5
EC2	Address 3	OT15 OT16	Adr. 6 Adr. 7
EC3	Address 0	OT17 OT18	Adr. 0 Adr. 1
EC3	Address 1	OT19 OT20	Adr. 2 Adr. 3
EC3	Address 2	OT21 OT22	Adr. 4 Adr. 5
EC3	Address 3	OT23 OT24	Adr. 6 Adr. 7

The outdoor sensor value is only transmitted by the automatic OT units connected to the EM 110 with address 0.

Provided that the connected OpenTherm burner control supports the functions, the following can be set

Heating set point

- domestic hot water set point
- can be transmitted.

The interface converts the following OpenTherm data points, provided they are supported by the automatic burner control:

- outdoor temperature
- Flow temperature
- Return temperature
- Flue gas temperature (optional)
- Current boiler output (optional)

- Flame detection
- Water pressure (optional)
- Domestic hot water temperature (optional)

#### **Communication error**

- RS485 RMCI:

If there is no data communication on the RS485 RMCI interface, OpenTherm communication will be set off both interfaces after 20 seconds, thus resetting the automatic burner control to automatic operation without OT connection.

- OpenTherm 1 / 2

If no OpenTherm slave is connected to an interface, after a timeout of 60 sec. the corresponding address (OT1 / OT2) of the RMCI data Requests will no longer be answered. Thus the error message no data connection becomes active in the controller.

#### **Fault messages automat**

The OpenTherm does not provide differentiation between fault messages and blocking messages. Therefore OEM error codes from the OT data transmission are passed through as error codes.

#### **Power control**

If the connected automatic burner control supports power control, this is also supported by the interface.

#### **Minimum load control (OT)**

The OpenTherm minimum load control (short burner run times) is not supported!

## 5.5 heatcon! GBA



Fig. 9: heatcon! - GBA

- 1 Device bus plug contact
- 2 Device bus screw terminals

Pin assignment device bus cable

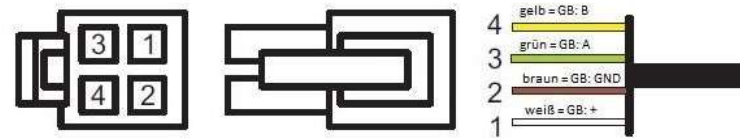

- 4 yellow = GB: B
- 3 green = GB: A
- 2 brown = GB: GND
- 1 white = GB: +

### To be used

The heatcon! GBA is required if extended wiring of the devices is necessary.  
 For connecting cascades with more than two heatcon! EC.  
 For larger distances between the heatcon! EC within a cascade.  
 The heatcon! GBA has no amplifier function (repeater).

## 5.6 heatcon! RC 130



The **heatcon! RC 130** is used as a remote control for room groups (heating circuits) in the **heatcon!** System. The temporary desired temperature can be set with the + or - keys. The RC 130 is integrated into the **heatcon!** system by means of addressing and can be assigned to a **heatcon!** EC and a room group (1 of max. 5) or, with individual room control, a room (1 of max. 24). This assignment is done exclusively at the **heatcon!** RC 130.

The **heatcon!** RC 130 is connected via a 2-wire bus with the **heatcon!** EC.

Each room group in the **heatcon!** System can be assigned a **heatcon!** RC 130.

The assignment of the RC130 to the active heating zones (room groups):

Fig. 10: *heatcon!* RC 130

Connect at:	Adress EC:	RC130-No.:	Adress on RC130:
EC 1	ADR0	1	EC01 RC01
EC 1	ADR0	2	EC01 RC02
EC 1	ADR0	3	EC01 RC03
EC 1	ADR0	4	EC01 RC04
EC 1	ADR0	5	EC01 RC05
EC 2	ADR1	6	EC02 RC01
EC 2	ADR1	7	EC02 RC02
EC 2	ADR1	8	EC02 RC03
EC 2	ADR1	9	EC02 RC04
EC 2	ADR1	10	EC03 RC05
EC 3	ADR2	11	EC03 RC01
EC 3	ADR2	12	EC03 RC02
EC 3	ADR2	13	EC03 RC03
EC 3	ADR2	14	EC03 RC04
EC 3	ADR2	15	EC03 RC05

## 5.7 Single room control heatapp!



Fig. 11: heatapp!

The *heatcon!* System can be expanded with the wireless single room control *heatapp!* to provide single room control for up to 24 rooms.

To do so, the *heatapp!* gateway must be connected via the Ethernet interface with the *heatcon!* EC.

Operation is via a tablet or smartphone using the *heatapp!* App.

For more information about the *heatapp!*-System see <https://ebv-gmbh.eu/en/downloads/heatapp!-system/>

## 6 Operation and extended configuration

### heatcon! ECxxx PRO operation



Configuration and operation of the *heatcon! EC PRO* can take place in three ways:

- Configuration and operation via the control unit *heatcon! MMI* (in-situ).
- Configuration and operation via PC (in-situ).
- Configuration and operation via *heatapp! App* installed on a tablet or smartphone. Remote control and remote maintenance via the Internet is possible.

The app accesses the *heatcon! EC PRO* at home. To do this, the *heatcon! EC PRO* must be connected to the router and the WLAN connection on the tablet or smartphone must be set up correctly.

Alternatively, access can also be made externally via a secure connection if *heatapp! connect* is activated.

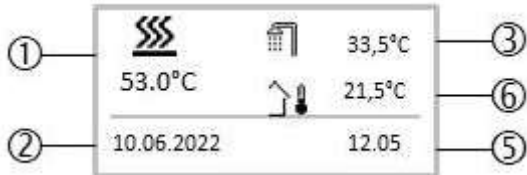
Operation via the *heatapp!* app or via the internet browser of a PC, tablet or smartphone requires that installation via PC, tablet or smartphone (mobilephone) has also been carried out.

heatcon! MMI	Computer or app operation												
<b>Basic display (MMI)</b>	<b>Tile view (Internet browser)</b>												
 <table border="1" data-bbox="91 858 1084 959"> <tr> <td>1</td> <td>Energy generator temperature</td> <td>4</td> <td>Outside temperature</td> </tr> <tr> <td>2</td> <td>Date</td> <td>5</td> <td>Time</td> </tr> <tr> <td>3</td> <td>Hot water temperature</td> <td></td> <td></td> </tr> </table>	1	Energy generator temperature	4	Outside temperature	2	Date	5	Time	3	Hot water temperature			
1	Energy generator temperature	4	Outside temperature										
2	Date	5	Time										
3	Hot water temperature												
<p>After switching on the power supply, the basic display of the <i>heatcon! MMI</i> is displayed. The following temperatures are displayed in the factory:</p> <ul style="list-style-type: none"> <li>• Energy generator - temperature</li> <li>• Hot water temperature</li> <li>• Outside temperature</li> </ul> <p>The temperatures shown in the basic display can be adjusted.</p>	<p>After completing the setup wizard, you will be taken to the tile view of the <i>heatcon! EC</i>. There are three important areas for completing the installation:</p> <p>Expert = for advanced installation and to retrieve the system's information.</p> <p>Establishment protocol = for logging the executed establishment</p> <p>System management = for creating a data backup to be able to reset the system to this status if necessary.</p>												



## heatcon! MMI

### Menu navigation

Operation takes place via the rotary button and the menu buttons on the heatcon! MMI.

#### Rotary button

The rotary button is used to navigate through the menus and change parameters and values.

Action		Description
Rotation		Navigation through the menus. Setting of parameters and values..
Brief press (1x)		Selecting menus and parameters. Confirmation of parameter inputs.
Long press (>3s)		Calling the main menu.

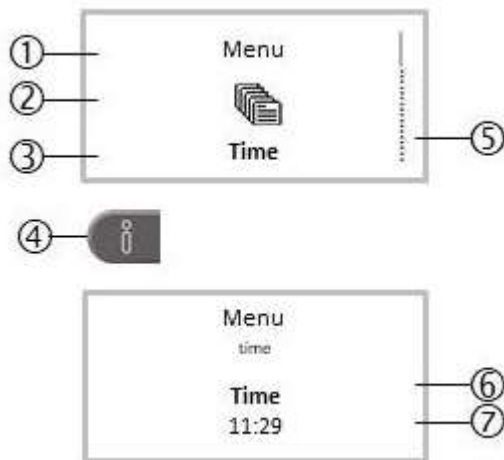

1	Menu level	5	Scroll-Balken
2	Menu-Symbol	6	Parameter
3	Submenu	7	Current value
4	Info-Taste		

### Selecting and changing of menus and parameters

## Computer or app operation

The Expert menu is divided and changes depending on configuration.

Information and changeable for each area. These differ selection of the energy A complete parameter list chapter Parameter from



into different sections the hydraulics and parameters are available depending on the generator. can be found in the page 80.

### Example room group 1: Level information



## heatcon! MMI

If the scroll bar is displayed in the menu, there are further selection options in the menu. These are navigated through by turning the rotary button.

If menus/parameters are highlighted in bold, they can be selected by pressing the rotary button.

To change parameters, select the parameters highlighted in bold by pressing the rotary button to edit them.

Now the value of the parameter is highlighted in bold and can be changed by turning the rotary button.







Press the rotary knob to save the setting.

### Function of the Info button

The info button has a special function in menus. Pressing the info button moves backwards through menu levels.

### Speed buttons

Functions are activated/deactivated via the speed buttons. Certain menus can be called directly to quickly change values.

Button	Description
	Quick press: Start emission measurement. Long press (about 5 seconds): Energy generators manual mode activation.
	Calls the menu "Scenes and operation modes". The Scenes and Operating Modes button has a special function in menus. Pressing the Scenes and Operating Modes button returns the display to the basic view.
	Calls the menu "Cycle times".
	Calls the menu "Information".
	Calls the menu "Comfort and Economy Temperature".
	Calls the menu "Set-back Temperature".
	Calls the menu "Hot Water".

## Extended installation MMI

## Computer or app operation

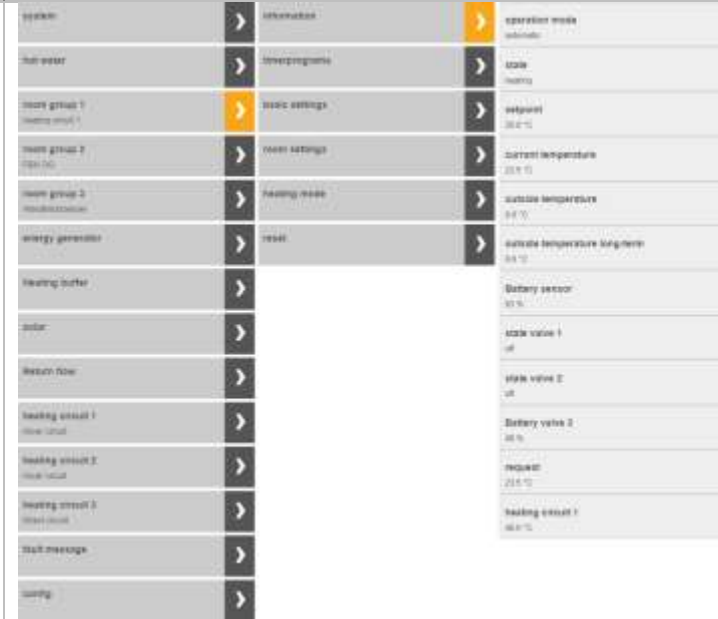

### Heating mode level



## Internetbrowser

## heatcon! MMI

Entering the specialist code 1 2 3 4 (access right)

- Press the rotary knob until Time appears in the display.
- Turn to the left until MMI appears and confirm by pressing the rotary knob.
- Turn to the right until Access right appears in the display and confirm by pressing.
- Enter the specialist code 1 2 3 4 by turning and pressing.



For further configuration of the Controller, the Configuration menu is called up.

- Enter the specialist code
- Then press the i key until MMI appears in the display again.
- Turn to the right until Configuration appears in the display and confirm by pressing.
- Select Function to activate further functions or Hardware to configure inputs and outputs.

## Computer or app operation

If the specialist's access data was entered during login, no additional specialist code is required.

If the login is as an owner, click on the "Manufacturer code" button at the bottom right and enter 1234.

**manufacturer-code**

For further configuration of the controller, the Configuration menu is called up.

Click on "Configuration"

Select Function to activate further functions or Hardware to configure inputs and outputs.

## My system

Not available on MMI.



In the "*My system*" area you can edit the name and location of the **heatcon!** system. Detailed information about **heatcon! EC** and **heatapp! gateway** are also displayed here.

1. Tap on the corresponding input fields to change the system name or system location.
2. Tap on "Save" to apply the settings.

Tap button  to return to the "*System*" menu.

## heatapp! gateway

Not available on MMI.



In the "**heatapp! gateway**" area, the currently connected **heatapp! gateway** is displayed together with all the device details.

- You can call the **heatapp! gateway** menu by tapping the button "To the **heatapp! gateway** menu".
- If another **heatapp! gateway** is to be connected, you can delete the connection of the **heatcon! EC** to the **heatapp! gateway** by tapping on the "Remove connected **heatapp! gateway**" button.

Tap button  to return to the "*System*" menu

### NOTE

The **heatapp! gateway** menu can only be called in the local network. Calling the **heatapp! gateway** menu via **heatapp! connect** is not possible.

## Establishment protocol

Not available on MMI.

In the "Establishment protocol" area an establishment protocol can be generated and sent by e-mail. The establishment protocol contains all the information about your heatcon! **configuration.**

Generating the establishment protocol

- A new report is created by tapping on the button "Generate a new establishment protocol".

The establishment protocol is saved in the heatapp! base until a new establishment protocol is generated.

This means that at any time you can access the last generated establishment protocol (button "Display establishment protocol") and / or send a PDF by e-mail (button "Send establishment protocol").

Sending an establishment protocol by e-mail

1. Tap on the button "Add a new e-mail address".
2. Enter the new e-mail address to which the establishment protocol is to be sent. You can enter more than one e-mail address.
3. Tap on "Send establishment protocol" to send the establishment protocol.

If the establishment protocol has been sent successfully, a corresponding message is displayed.



Tap button  to return to the "System" menu.

## Notifications

Not available on MMI.



The **heatcon!** system sends push and e-mail messages in the event of faults or service notifications.

Push messages are system notifications, which the **heatcon! EC** sends directly to the user interface of the mobile device (smartphone / tablet), so that the user is immediately informed. These may be fault messages or service notifications.

E-mail addresses that are to be used for the sending of automatic push messages can be saved under the "Notifications" menu item. These e-mail addresses can likewise be offered as possible distribution addresses when sending the establishment protocol.

Tap on the desired users to specify which individual users are to receive the notifications.

Tap button  to return to the "System" menu.

## Network

Not available on MMI.



The current network settings are displayed in the "Network" area. This is where you can change the network configuration, e.g. if for example a Wi-Fi is to be set-up after the initial configuration. You can also activate the connection to **heatapp! connect** from here.



You can also activate the continuous improvement process here to send anonymous reports to **heatapp!** In this way you actively help to improve the system further.



Tap button to return to the "System" menu.

**network**

heatcon! ec has to be integrated into the network to allow access. Please chose your network connection.

<input type="checkbox"/> network connection via LAN	192.168.108.115	<input checked="" type="radio"/>
<input type="checkbox"/> network connection via WLAN		<input type="radio"/>
<input type="checkbox"/> proxy server configuration		<input checked="" type="radio"/>
Internet connectivity		
Network connectivity		

Apply network configuration

### heatapp! connect

Would you like to operate the heating system from anywhere via Internet? Acitvate the connection to heatapp! connect.

yes  connection to heatapp! connect

Connected successfully to heatapp! connect.

### Participation in the continuous improvement process

Allow the system to send anonymous usage data to participate in the continuous improvement process.

no Activate participation in the continuous improvement process

## Date / Time

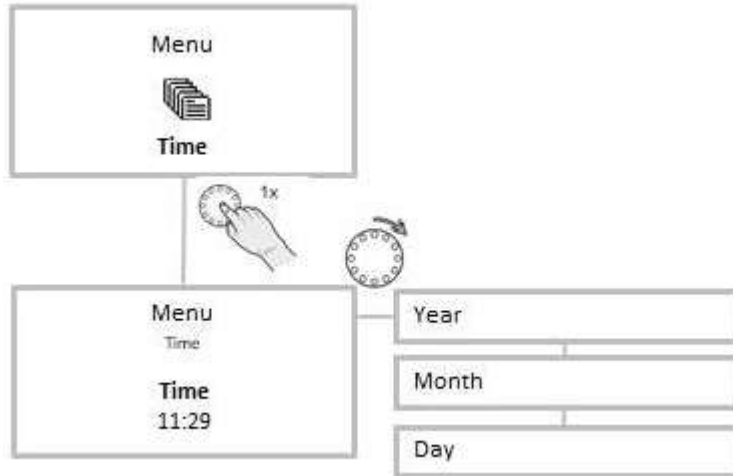

You can make the settings for the real-time clock in the "Date / time" area. For example, this is necessary, if the manual time setting was selected (summer / winter time).

You can select between the following variants:

- Time synchronisation via the Internet
- Time synchronisation via an internal NTP server
- Manual time setting

Tap on "Save" to apply the settings.



Tap button to return to the "System" menu.

**Date / time**

system time: 13.09.2018 12:02 (Europe/Berlin)

time zone: Europe/Berlin

**time synchronisation**

automatic internet synchronisation

automatic time sync with your own NTP server

manual time setting

The time and date will be synced automatically with the standard time servers through the internet connection.

**Save**

---

**time synchronisation**

automatic internet synchronisation

automatic time sync with your own NTP server

manual time setting

Add the NTP server for automatic time synchronisation.

ntp server:

**Save**

---

**time synchronisation**

automatic internet synchronisation

automatic time sync with your own NTP server

manual time setting

Please enter the current time for the biological time.

transfer: **Transfer time to the device**

date: 2018 09 13

time: 08 30 12

**Save**

## Setup wizard



See also section "Initial operation", on page 61.



The "Setup wizard" menu item relaunches the setup wizard. This may be for example be due to a move and changed connection to the boiler.  
See also section "Initial operation", on page 41.

## System management

Not available on MMI.



In the "System management" area, you can update the **heatcon!** system software and perform a data backup.

Updating the system software

EbV works constantly to improve the **heatcon!** system. To ensure our customers can benefit from this, we have developed an update system, which means you are always offered the latest version.

You decide whether you want to install the offered update or would prefer to retain the existing version.

A display appears below the current software indicating whether a software update is available.

### NOTE

Software updates are only displayed, if the **heatcon!** system is connected to the Internet.

If you perform a software update of the **heatcon! EC**, please check whether the new software is compatible with the software of the **heatapp! gateway**.

If necessary, you may also need to perform a software update for the **heatapp! gateway**.  
When updating the device software by downloading via the Internet additional costs may be charged depending on the customer's actual Internet tariff.



## ATTENTION

It is not possible to update the MMI 200 via the Internet. An update of the MMI 200 is only necessary in exceptional cases (new functions of the MMI). Please send the MMI 200 to the manufacturer EbV.

The "**Restart system now**" button triggers a restart.

Restarting the system deletes the data in "Live View". Monitor data is only retained if it is saved on a USB stick.

### NOTE

A restart of the heatcon! system deletes the stored data of the "Live View". If the USB data backup of the monitor is activated, the data on the USB stick will of course be retained and can still be used.

Reset to factory settings

The "Reset now" button, resets the device to the factory settings

### NOTE

Upon resetting, all set data is irrevocably lost and a new setup is necessary. Please only use this option, if expressly Requested to do so by our customer support or your expert.

### Monitor

The monitor shows current and historical data of your heating system. If you wish to store the data for more than 24 hours, insert a USB memory stick into the system and activate the storage option.

The system will store the data until the USB memory space is exhausted. The oldest data will then be overwritten automatically.

### NOTE

- Before removing the USB memory stick from the system, please disable the option to avoid data loss.
- The data will be overwritten automatically without warning. If you want to keep the data permanently, always make sure that there is enough memory on the USB memory stick.

### System data backup

You can perform a data backup using a USB stick. Using this back-up system you can transfer the installation to a new device or after resetting of the system, quickly return to the backed up condition.

1. Insert a USB stick in a free USB port of the heatcon! system.
2. Tapping the "OK" button saves a backup file on the USB stick.

### Restoring the backed-up system data

If you want to restore a **heatcon!** system that is in the delivered condition using a backup from a USB stick, you must first run the setup wizard to recreate the basic settings.

Alternatively, open the setup wizard via PC / Laptop and enter the following link in the address bar to go to the system management page:

With USB-LAN adapter or installation stick: **10.0.0.1/admin/system/index** (USB switch needed)

Via the IP address with Computer / Laptop: **IP address/admin/system/index**

1. Insert a USB stick with a data backup file in a free USB port of the heatcon! system.
2. Select the required backup file.
3. Tapping the "Update" button transfers the selected backup to the system.

Tap button  to return to the "System" menu.

## Monitor

Not available on MMI.



The monitor shows current and historical data of your heating system..

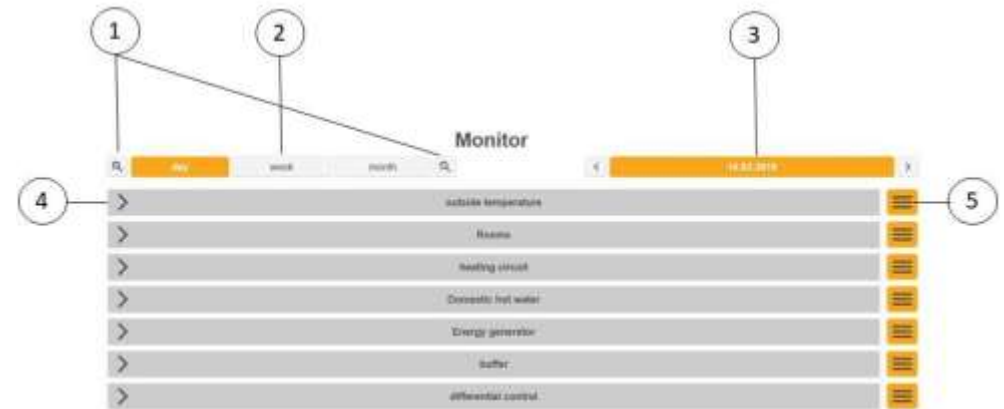

Fig. 12: Monitor homepage

1 Zoom in / zoom out the X-axis (horizontal axis)

2 Selection day / week / month

3 Selection date

4 Representation of the individual areas

5 Menu

Tap / click on the arrow (4) to open the display of the respective area.

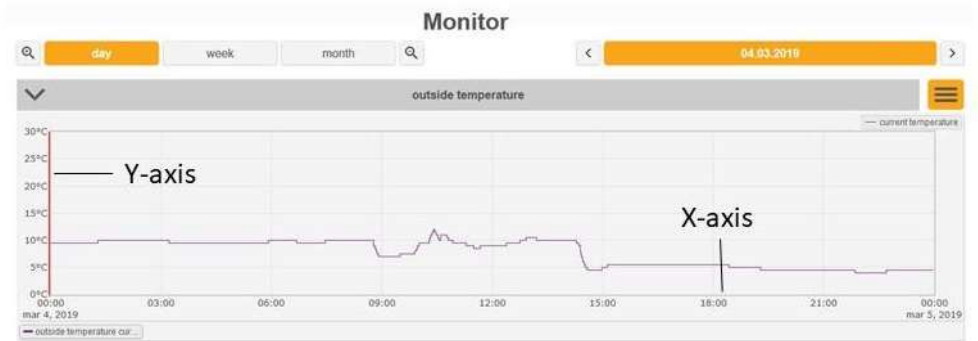

Fig. 13: Monitor Outsidetemperatur

Selection options are available by tapping / clicking on the menu.

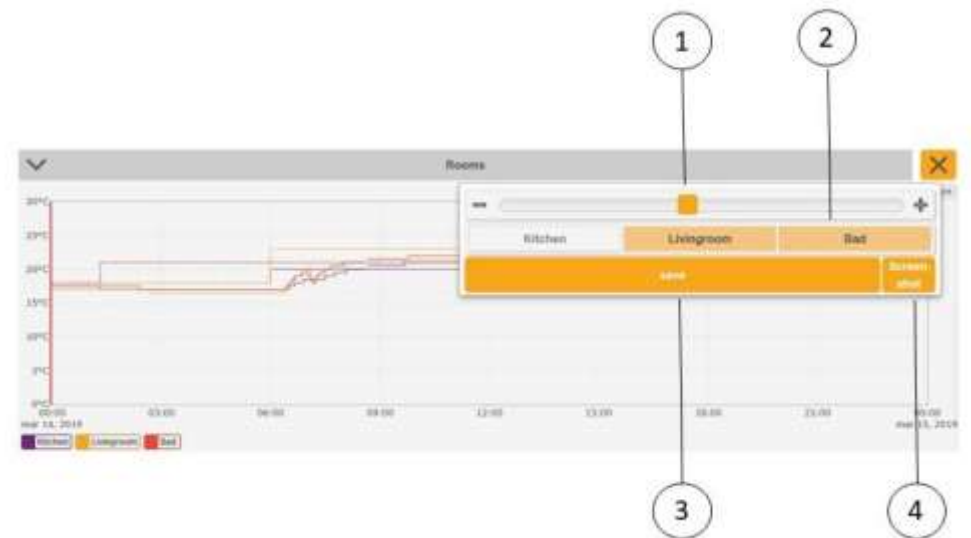

Fig. 14: Monitor Menu

1 Zoom in / zoom out the Y-axis (vertical axis)

3 Safe

2 Selection of room / heating circuit / sensor and so on

4 Create screenshot (only possible on computer / laptop)

The selected areas are highlighted in orange in the menu. White areas are not selected.

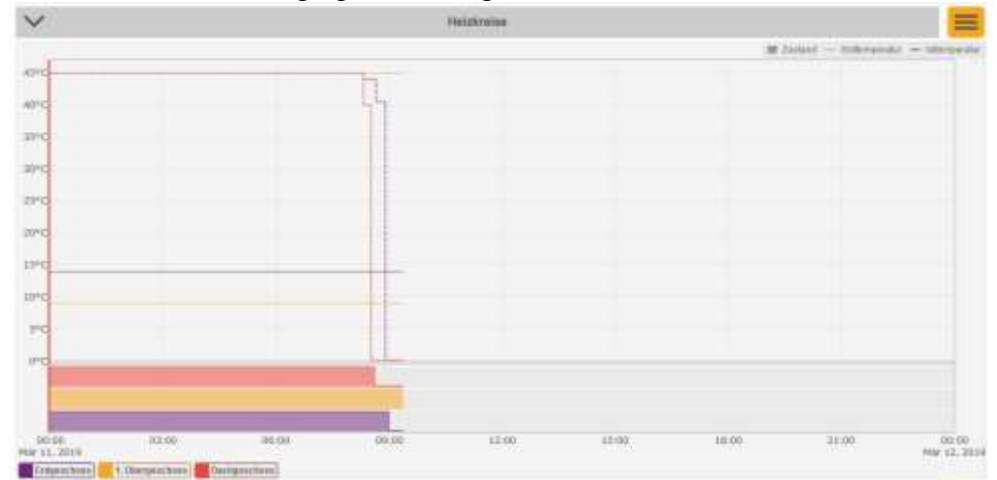

Fig. 15: Monitor State

All selected areas (outdoor sensors, rooms, heating circuits, etc.) are displayed below the diagram as a legend. Individual areas can be hidden by clicking / tapping. The status is displayed below the diagram. A full bar shows the activity, an empty bar the inactivity of the respective device (heating circuit, Pump, energy generator and so on).

The red vertical line moves by double-clicking / tapping on the desired time. This allows the comparison of the individual graphs. This makes it easy, for example, to find out where the Request comes from.

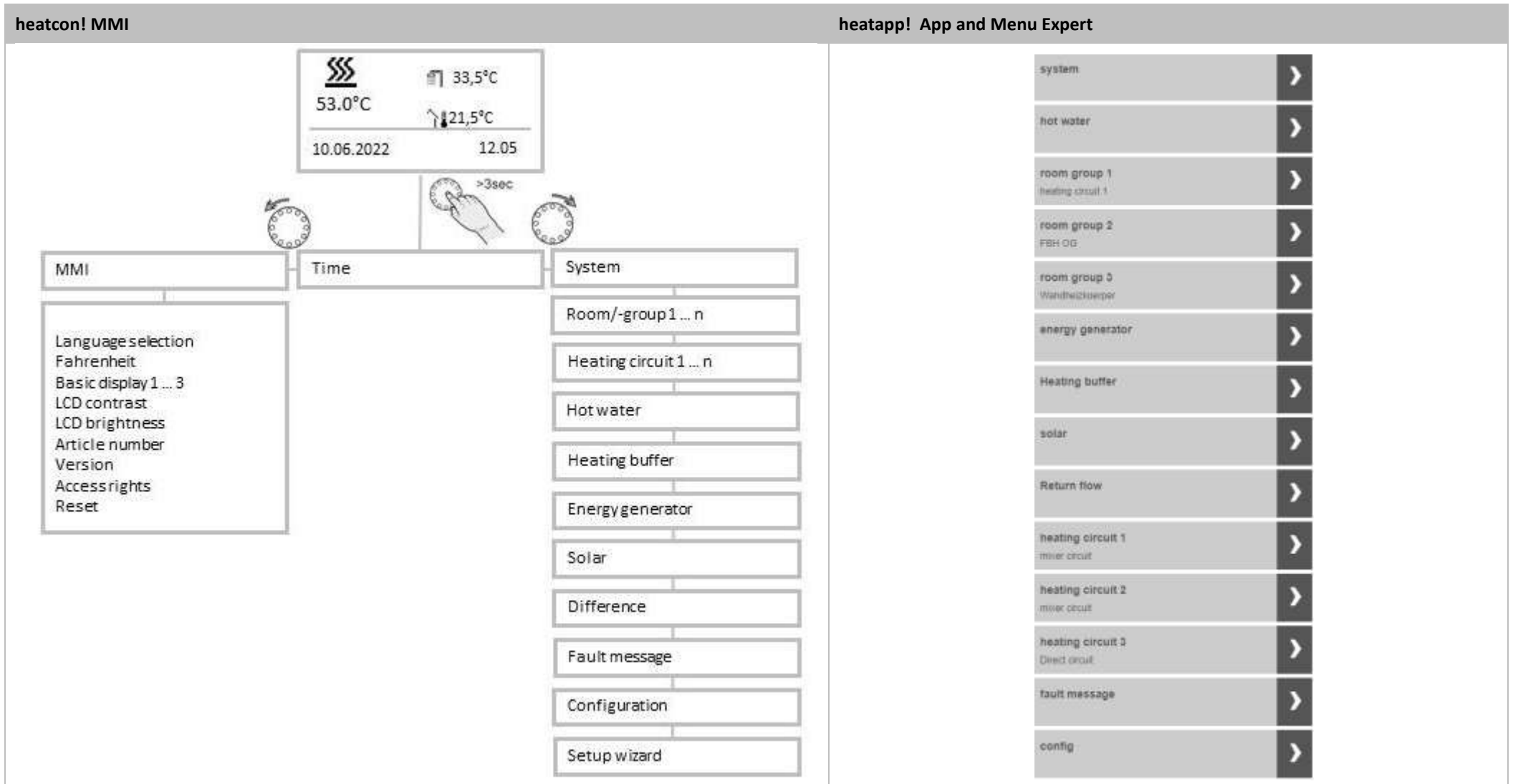

Fig. 16:: Monitor as analytical tool

## 6.1.1 Menu overview

### NOTE

The scope of the displayed menus and parameters depends on the system configuration and may differ from the diagram.



## 6.1.2 MMI Basic display konfigurieren

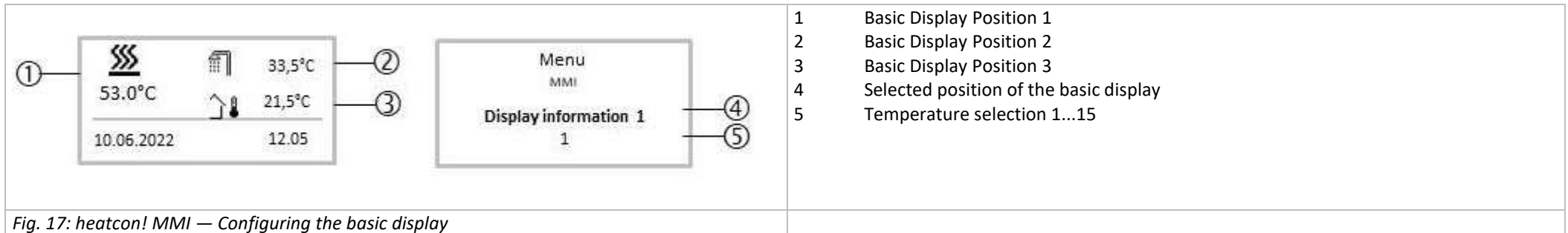

Fig. 17: heatcon! MMI — Configuring the basic display

The temperatures shown in the basic display can be selected via the MMI menu. The basic display has three display positions that can be filled with 15 different temperatures.

Examples are given in the following table:

Selection	Symbol	Description
OFF	—	No display.
1		Energy generator - temperature
2		Hot water temperature.
3		Outside temperature.
4		Flow temperature heating circuit 1
5		Flow temperature heating circuit 2
6		Flow temperature heating circuit 3
7		(only modulating Pump with FS)

Selection	Symbol	Description
8		Cooling buffer temperature (not used)
9, 10, 11		Flow temperature differential controller 1...3
12		Common flow temperature
13		Return temperature
14		Thermostat switching state
15	—	Not used
16		Energy generator 2 - temperature



## 6.1.3 Speed button functions MMI

### 6.1.3.1 Emission Measurement

#### ▲ CAUTION

**Risk of scalding!**

**Risk of scalding during activated emission measurement by heating of the hot water above 60°C.**

- **Only qualified personnel may activate the "Emission Measurement" function.**
- **Before activating the "Emission Measurement" function, inform the users of the hot water system of the risk of scalding.**
- **When using hot water taps, mix in sufficient cold water.**

When emission measurement is activated, the energy generator regulates for the duration of 20 minutes according to the maximum temperature limit set for the energy generator. The remaining time is continuously displayed.

With 2x single-stage GEN, the emission measurement can be activated individually for each stage.

With 1x two-stage GEN, both stages are in operation (measurement with nominal output).

All heating circuits and also the hot water preparation regulate their Setpoint to the respective maximum temperature.

Off for blocked GEN (summer/winter block or external GEN block) the emission measurement can be activated. The blocking is cancelled for this time..

#### **Activating:**

To activate emission measurement, press the Emission measurement/manual mode" button.

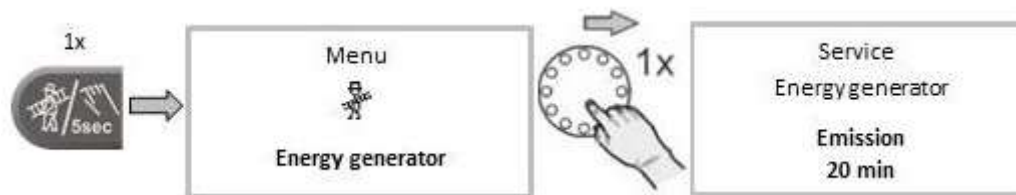

Fig. 18: Emissions measurement

#### **Deactivating:**

To deactivate emission measurement, press the Emission measurement/manual mode" button again.

### 6.1.3.2 Manual mode

If manual mode is activated, the required heat generator temperature is set manually with the rotary button according to the relevant heat demand (does not have any effect if operated as a heating circuit expansion).

All the Pumps are active, while the available mixing valves are de-energized and can be actuated by hand if required for the heat demand.

Activating:

1. To activate manual mode, press the "Emission measurement/manual mode" button for 5 seconds and then release.
2. Set the desired temperature of the energy generator using the rotary wheel. The Setpoint is adjustable between the minimum and maximum temperature of the energy generator.
3. If necessary, manually adjust the mixers present in the heating circuits.

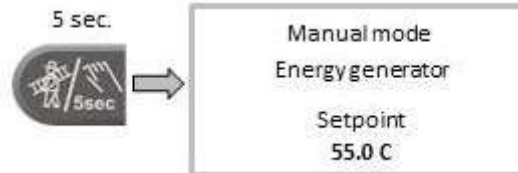

Fig. 19: Manual mode

Deactivating:

To deactivate manual mode measurement, briefly press the Emission measurement/manual mode button.

#### NOTE

- The heat generator maximum temperature limit takes priority over the heat generator switching difference and deactivates the heat generator if it is exceeded.
- The switching difference corresponds to the set switching difference for automatic control and is symmetrical to the Setpoint temperature.
- With controllers that are operated purely as an expansion of the heating circuits, setting the temperature has no effect.
- The last value appears as a suggested value after the controller has adjusted to the heat generator temperature.

### 6.1.3.3 Operation modes and scenes

The operation mode can be set for the individual room groups (heating circuits), the hot water heating or for the entire system in the menu "Scenes/operation modes".

MMI	heatapp! App																
<p>The operation mode can be set for the individual room groups (heating circuits), the hot water heating or for the entire system in the menu "Scenes/operation modes".</p>	<p>In the heatapp! app, the operating modes are activated/deactivated using scene icons on the home screen. The active operating mode is displayed in the room picture.</p>																
 <p>The diagram illustrates the MMI interface. On the left, a '1x' icon is shown above a menu with five options: 'Room group 1 Heating circuit 1', 'Room group 2 Heating circuit 2', 'Room group 3 Heating circuit 3', 'Hot water', and 'System All rooms and dhw'. A hand is shown selecting 'Automatic' from a list of options on the right. The list includes 'Automatic', 'Standby', 'Party Aus', 'Absent Aus', and 'Vacation 01.07'. Arrows indicate the flow from the menu to the selection screen.</p>	<table border="1"> <tbody> <tr> <td data-bbox="1137 443 1303 517"></td> <td data-bbox="1312 443 2152 517">Automatic mode comfort-temperature. Heating mode is active after the set cycle time.</td> </tr> <tr> <td data-bbox="1137 523 1303 596"></td> <td data-bbox="1312 523 2152 596">Automatic mode set-back-temperature. Reduce mode is active after the set cycle time.</td> </tr> <tr> <td data-bbox="1137 603 1303 676"></td> <td data-bbox="1312 603 2152 676">Scene Boost active for the room according to preset parameters.</td> </tr> <tr> <td data-bbox="1137 683 1303 756"></td> <td data-bbox="1312 683 2152 756">Scene holiday active for the room</td> </tr> <tr> <td data-bbox="1137 762 1303 836"></td> <td data-bbox="1312 762 2152 836">Go scene active for the room</td> </tr> <tr> <td data-bbox="1137 842 1303 916"></td> <td data-bbox="1312 842 2152 916">Scene Party active for the room</td> </tr> <tr> <td data-bbox="1137 922 1303 995"></td> <td data-bbox="1312 922 2152 995">Scene showers active for the room</td> </tr> <tr> <td data-bbox="1137 1002 1303 1187"></td> <td data-bbox="1312 1002 2152 1187">Scene Standby ... frost-protected switch-off of the heating of the selected rooms. Scene Standby must be ended manually.</td> </tr> </tbody> </table>		Automatic mode comfort-temperature. Heating mode is active after the set cycle time.		Automatic mode set-back-temperature. Reduce mode is active after the set cycle time.		Scene Boost active for the room according to preset parameters.		Scene holiday active for the room		Go scene active for the room		Scene Party active for the room		Scene showers active for the room		Scene Standby ... frost-protected switch-off of the heating of the selected rooms. Scene Standby must be ended manually.
	Automatic mode comfort-temperature. Heating mode is active after the set cycle time.																
	Automatic mode set-back-temperature. Reduce mode is active after the set cycle time.																
	Scene Boost active for the room according to preset parameters.																
	Scene holiday active for the room																
	Go scene active for the room																
	Scene Party active for the room																
	Scene showers active for the room																
	Scene Standby ... frost-protected switch-off of the heating of the selected rooms. Scene Standby must be ended manually.																

Fig. 20: Operation mode

Operation mode	Description
Automatic	Automatic mode for the selected heating circuit.
Standby	Operation mode " <i>Standby</i> " sets the room Setpoint in the allocated rooms to the set frost protection temperature. In contrast to the Vacation scene, the Standby function has no time limit. If the Standby function is activated for all the rooms/room groups, hot water heating is also switched off subject to frost protection.
Party	"Party" operation mode enables the overriding of the set cycle times for the rooms concerned. If "Party" operation mode is active, the corresponding comfort temperature applies for the rooms concerned. The operation mode is deactivated after the set runtime elapses. Setting range: Off ... + 12 h in steps of 0.5 h
Absent	"Absent" operation mode enables the overriding of the set cycle times for the rooms concerned. If the " <i>Absent</i> " operation mode is active, the corresponding set-back temperature applies for the rooms concerned. The scene is deactivated after the set runtime elapses. Setting range: Off ... + 12 h in steps of 0.5 h
Vacation	The "Vacation" operation mode is used to set the Vacation duration in days. To do so, the Vacation duration is entered from the current day in the format DD MM YY (day, month, year) using the rotary wheel. Activation of the Vacation function ensures that the temperature does not fall below the minimum temperature (frost protection) of the rooms. Hot water heating is deactivated for the duration of the operation mode. However a set Legionella protection scheme remains active. Setting range: Day/Month/Year adjustable.
Magic wand (Only by operation via heatapp! App)	In " <i>Magic Wand</i> " operation mode the desired temperature has been set via the rotary wheel in the <i>heatapp! App</i> . The change to the desired temperature is only valid until the next programmed time change, at least for 3 hours.

#### NOTE

Summer operation:

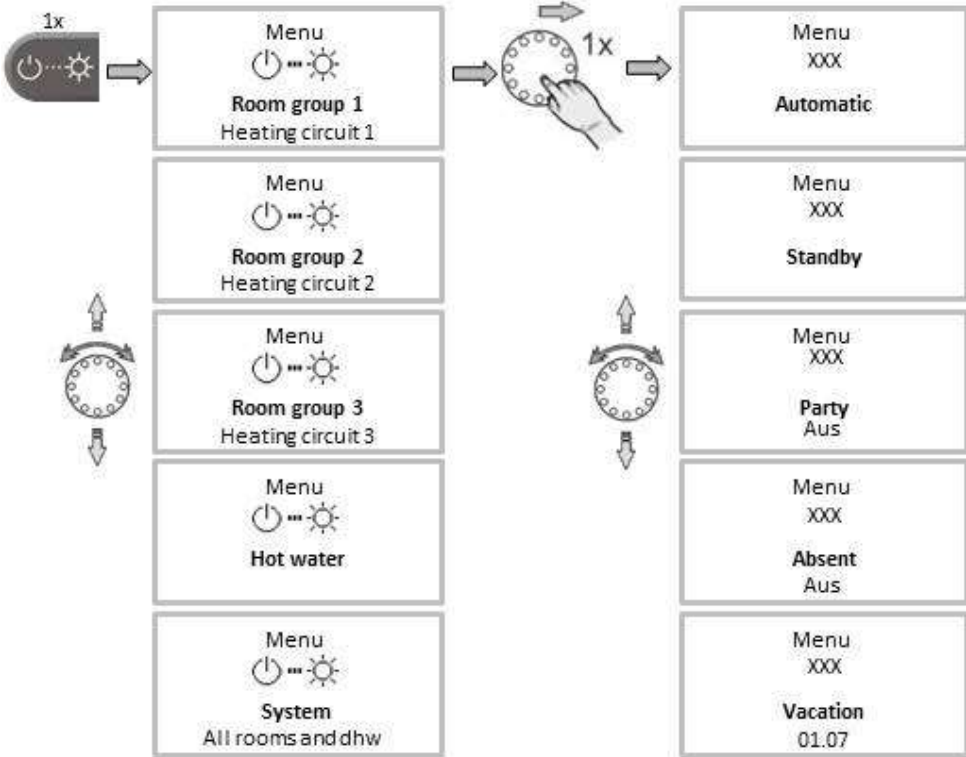
For summer operation (hot water only), the used room groups (heating circuits) must be set to the "Standby" operation mode, while the hot water circuit is set to "Automatic".

If the Request assignment to room was set in the Hot water basic settings menu, the hot water Request is linked to the room groups. This means that if **all** room groups are in shutdown mode (standby or vacation), the hot water circuit is also shut down frost protected.

### 6.1.3.4 Programming

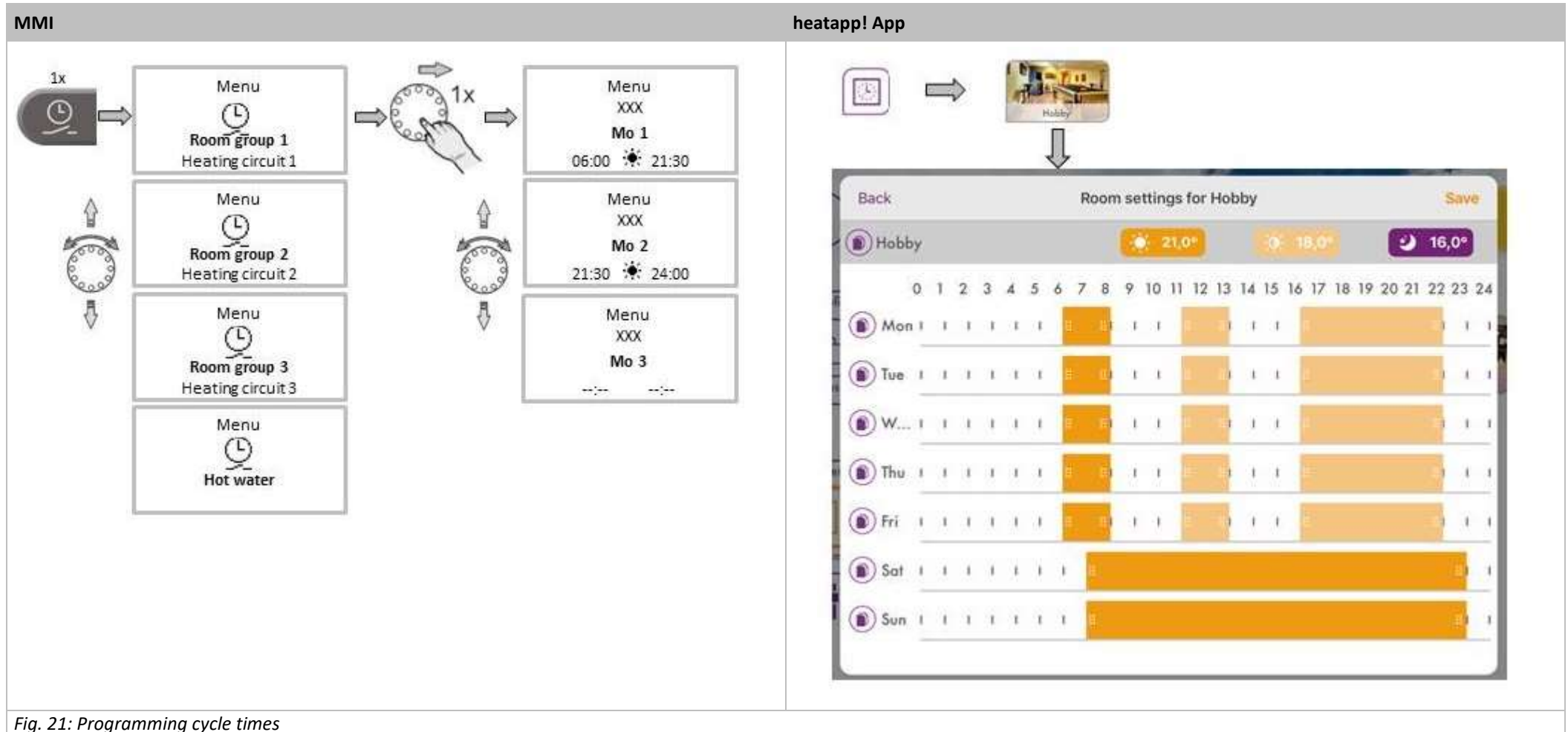

Fig. 21: Programming cycle times

In the "Programming" menu, individual switching cycles can be programmed for each room group (heating circuit) and the hot water.

For programming the switching times a maximum of three switching cycles, each with a switch-on and switch-off time, are available for each weekday. A choice can be made between comfort ☀ and economy temperatures 🌙.

### Setting the cycle time:

1. Select the desired room group/hot water.
2. Program the switching times for the day in question.
3. If necessary, select comfort ☀ and economy temperature 🌙.

### NOTE

The default factory program is overwritten as individual switching times are programmed. The individual programming can be recorded in the tables in the appendix or backed up by creating a setup log file.

### Copying cycle times:

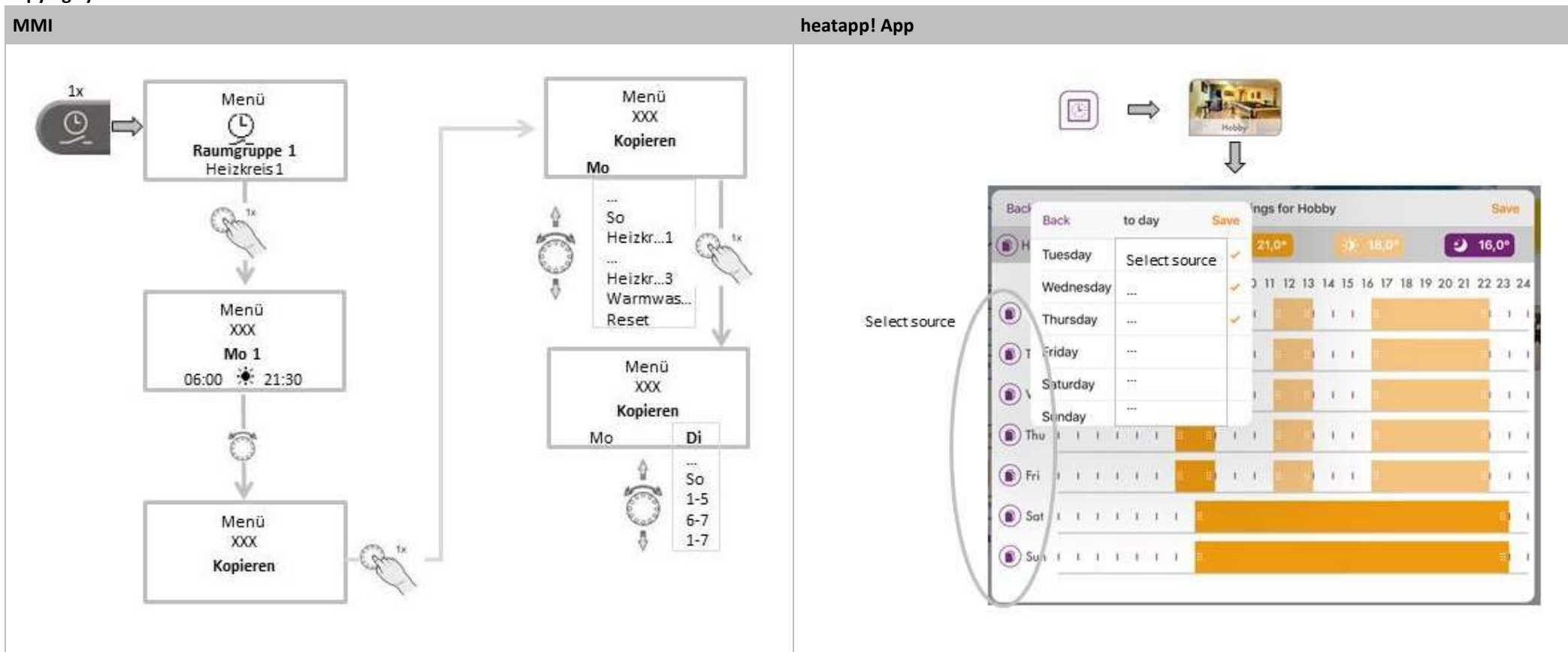

Fig. 22: Copying cycle times

The switching cycles of a particular day or of heating circuit 1 ... n / hot water can be transferred to other days.

1. Select "Copy" submenu.
2. Select the desired source to copy.
3. Select the desired target day.

The source switching cycles are transferred to the desired target day.

1. Tap the copy symbol of the day/room/room group/hot water from which the switching times are to be copied.
2. Select the desired days/rooms/room groups to which the switching times are to be copied.
3. Save

Source/target	Description
Mo ... Su	Day Monday .... Sanday
Heat cir... 1...n	Switching cycles of heating circuit 1 ... n as source
Hot water...	Switching cycles, hot water as source
1-5	Monday to Friday as target
6-7	Saturday and Sanday as target
1-7	Monday to Sanday as target
Reset	Reset as the source resets the corresponding target to the factory default program.

### 6.1.3.5 Information level

In the "Information" menu all available temperatures and system states can be displayed for each room group and each heating circuit. With optional connection to the *heatapp!* single room control, the room temperatures of the individual rooms can also be displayed.



MMI	heatapp! App and Menu Expert																		
 <p>The diagram illustrates the navigation process. It starts with a '1x' icon (an information symbol) pointing to a 'Menu' box containing 'Room group 1 Heating circuit 1'. A second '1x' icon (a hand pointing to a dial) points to an 'Information' box displaying 'Room group 1' and 'Operating mode Automatic'.</p>	 <p>The screenshot shows the 'heatapp!' interface. At the top, 'Room group 1 Heating circuit 1' is selected, followed by an 'Information' menu. The main display area shows the following data:</p> <table border="1"> <tr> <td>Operation mode</td> <td>Standby</td> </tr> <tr> <td>Statu</td> <td>Off</td> </tr> <tr> <td>Setpoint</td> <td>16.0° C</td> </tr> <tr> <td>Current temperature</td> <td>18.0° C</td> </tr> <tr> <td>Outside temperature</td> <td>9.0° C</td> </tr> <tr> <td>Outside temperature long-term</td> <td>12.5° C</td> </tr> <tr> <td>Battery sensor</td> <td>67 %</td> </tr> <tr> <td>Request</td> <td>-</td> </tr> <tr> <td>Heating circuit 1</td> <td>28.0° C</td> </tr> </table>	Operation mode	Standby	Statu	Off	Setpoint	16.0° C	Current temperature	18.0° C	Outside temperature	9.0° C	Outside temperature long-term	12.5° C	Battery sensor	67 %	Request	-	Heating circuit 1	28.0° C
Operation mode	Standby																		
Statu	Off																		
Setpoint	16.0° C																		
Current temperature	18.0° C																		
Outside temperature	9.0° C																		
Outside temperature long-term	12.5° C																		
Battery sensor	67 %																		
Request	-																		
Heating circuit 1	28.0° C																		

Fig. 23: Menu "Information"

#### NOTE

The "Information" menu is only used to display values. It cannot be used change values and parameters.

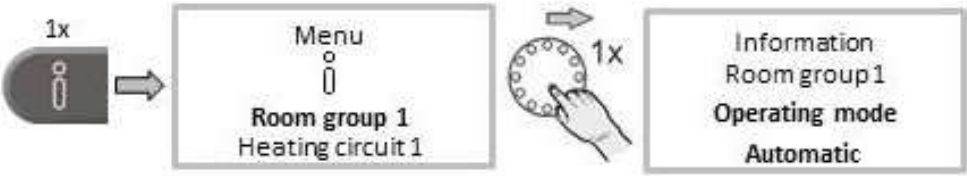

### 6.1.3.6 Comfort and economy temperature

The comfort and economy temperature are set for each room group and each heating circuit in the "Comfort/Economy Temperature" menu.

MMI	heatapp! App and Expert menu
	<p>The change from comfort to economy temperature is only possible via the heatapp! app. In the expert menu, it is only possible to set the setpoints for the comfort and economy temperature.</p> 
<p><b>Note</b></p> <p><b>Room group 1-n / Room 1-24:</b> The set temperature applies to the associated heating circuit or room.</p> <p><b>System:</b> The set temperature applies to all heating circuits and rooms together.</p>	

Fig. 24: Menu "Comfort/Economy Temperature"

#### Setting: the comfort/economy temperature:

1. Call menu "Day Temperatures".
2. Select the desired room group or system.
3. Set the desired comfort and economy temperature.

Factory preset		Setting range
Comfort temperature:	21 °C	Economy temperature ... 28 °C
Economy temperature:	20 °C	Set-back temperature ... Comfort temperature

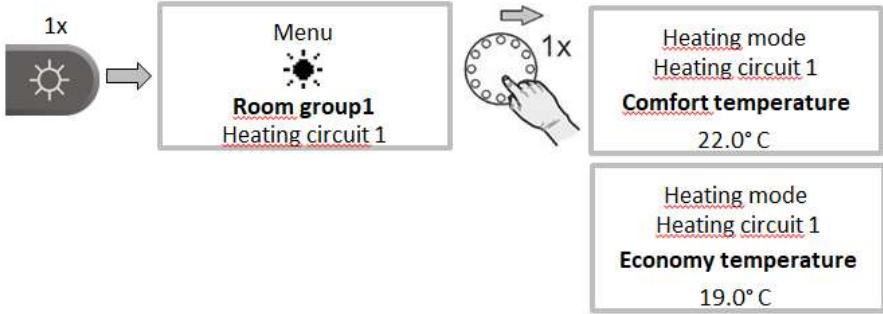
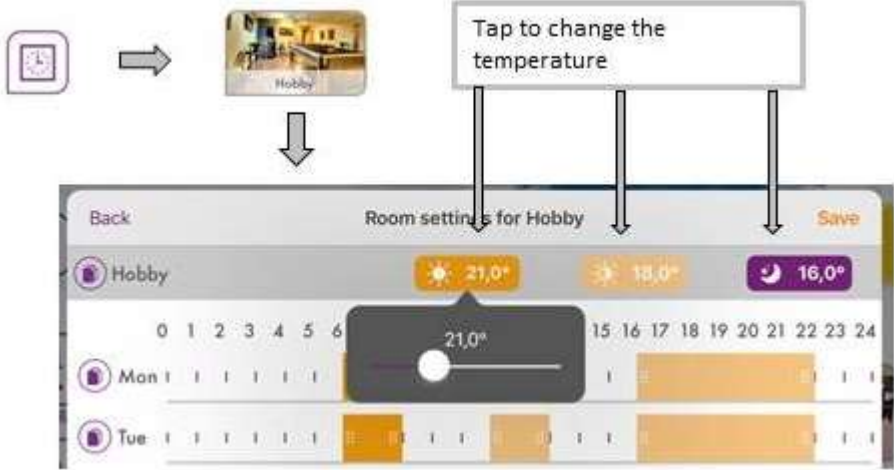
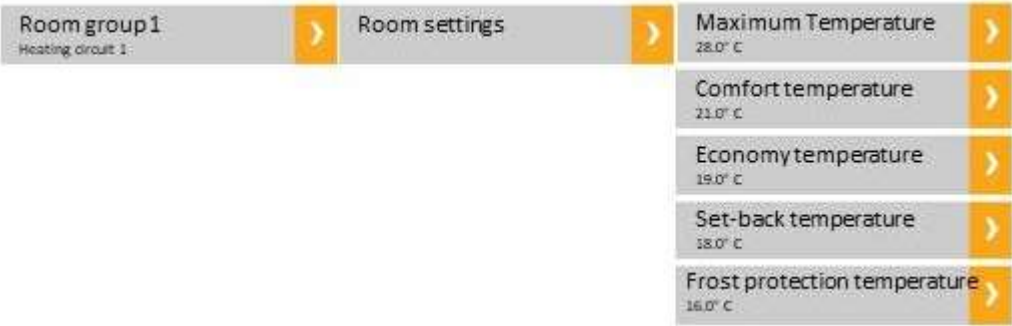
## NOTE

**Room group 1-n/Room 1-24:** The set temperature is valid for the respective heating circuit or room.

**System:** The set temperature is valid for all heating circuits and rooms together.

The *comfort, economy and set-back temperatures* for all rooms or room groups as well as the hot water temperature (system) can only be set within the pre-set temperature limits:

- The comfort temperature not less than the economy temperature.
- The economy temperature not above the comfort temperature and not less than the set-back temperature.
- The set-back temperature not above the economy temperature and not less than the frost protection temperature.

The set temperature is the starting value for the individually adjustable temperature settings during the heating cycles (cycle temperatures) in the "Cycle times" menu.

### 6.1.3.7 Set-back temperature

The set-back temperature is set for each room group and each heating circuit in the "*Set-back temperature*" menu.

MMI	heatapp! App and Expert menu

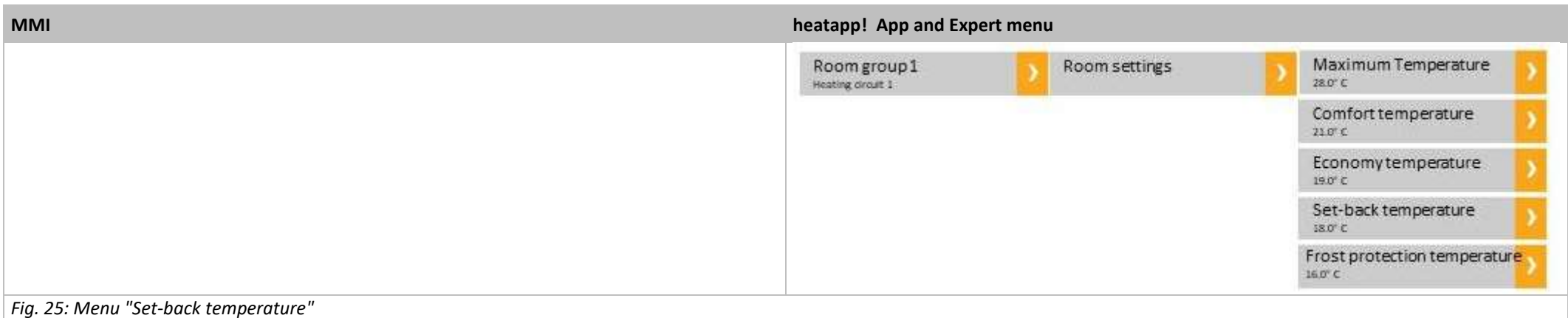

Fig. 25: Menu "Set-back temperature"

**Set the set-back temperature:**

1. Call menu "Set-back temperature".
2. Select the desired room group or system.
3. Set the desired set-back temperature.

Factory preset		Setting range
Set-back temperature:	18 °C	Frost protection temperature ... Economy temperature

**NOTE**

**Room group 1-n/Room 1-24:** The set temperature is valid for the respective heating circuit or room.

**System:** The set temperature is valid for all heating circuits and rooms together.

The *comfort, economy and set-back temperatures* for all rooms or room groups as well as the hot water temperature (system) can only be set within the pre-set temperature limits:

- The comfort temperature not less than the economy temperature.
- The economy temperature not above the comfort temperature and not less than the set-back temperature.
- The set-back temperature not above the economy temperature and not less than the frost protection temperature.

The set temperature is the starting value for the individually adjustable temperature settings during the heating cycles (cycle temperatures) in the "Cycle times" menu

### 6.1.3.8 Hot water

The hot water daytime temperature is set in the "Hot Water" menu.

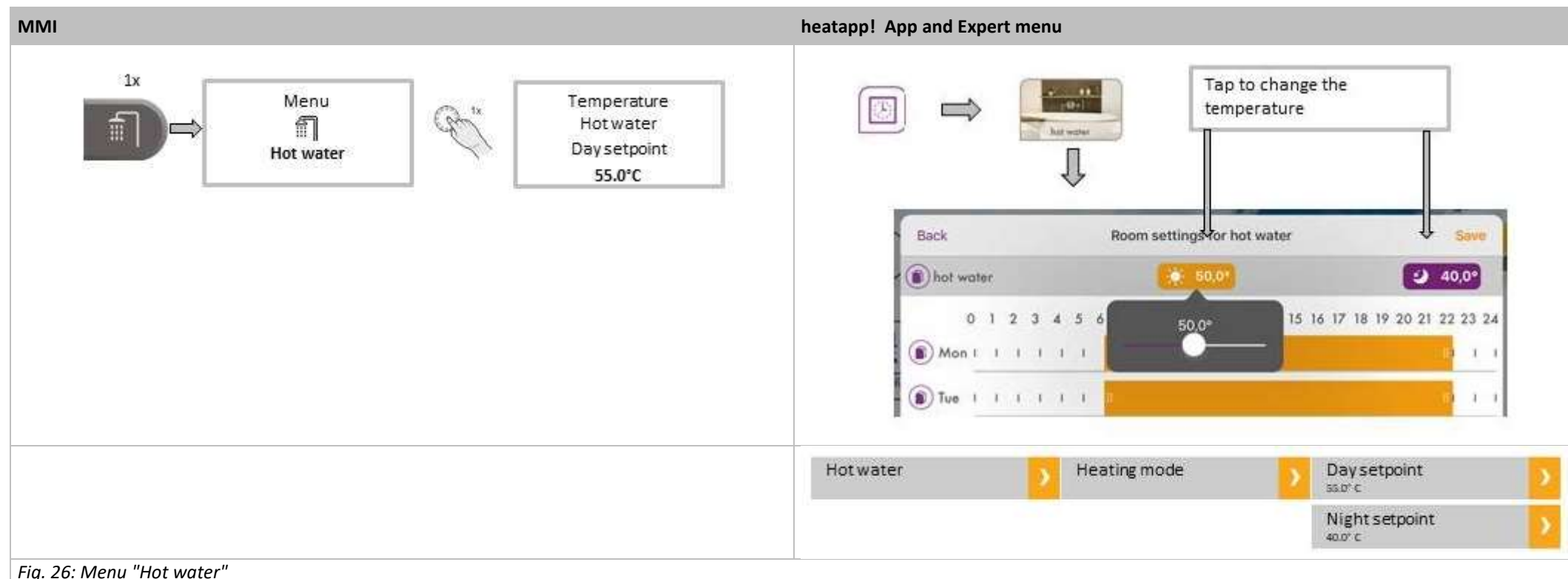

Fig. 26: Menu "Hot water"

#### Setting the hot water daytime temperature:

1. Call menu "Hot Water".
2. Set the desired hot water daytime temperature.

Factory preset		Setting range
Hot water daytime temperature:	50 °C	5 °C ... Water heater maximum temperature limit

#### NOTE

The set hot water daytime temperature is the starting value for the individually adjustable temperature settings applied during the standby cycles in the "Cycle times" menu.

## 7 Initial operation

Initial operation of the heatcon! EC can be started both on the MMI and in the web browser as a smart-home Controller.

### 7.1 Conditions and requirements

Prior to initial use of the controller, the following points must be fulfilled:

- The heating system must be made available in a fully complete state and filled with water to prevent damage to the Pumps by dry running and to the energy generator by overheating.
  - The controller must have been installed in compliance with the operating instructions.
- If an underfloor heating system is connected, then an additional limiting thermostat must be installed in the flow line downstream of the heating circuit Pump to switch off the Pump if the flow temperatures are too high.
- Prior to initial use of the controller all of the above requirements must be checked by a heating specialist.

### 7.2 Inbetriebnahme mit dem Einrichtungsassistent

For the initial setup of the heatcon! system, the system setup wizard is available:

- Setup Wizard in the in the heatcon! MMI
- Setup wizard via PC / laptop / smartphone or tablet

The details of how to set up the heatcon! System is described in chapter Setup wizard in heatcon! MMI and web browserstarting on page 68.

---

#### NOTE

---

During initial operation using the setup wizard, the assignment of the electrical inputs and outputs is performed according to the tables in the chapter "Energy generator 1 " on page 64.

---

### 7.3 Update heatcon! EC

If the heatcon! EC is connected to the Internet and the installation is done via PC/ Laptop / Smartphone (Mobilephone) or Tablet, the system will ask you to install a potentially available update during the initial setup. Alternatively, from version 2.136080 onwards, updates can be made via USB stick if an Internet connection is not possible or not desired.

---

#### NOTE

---

Updates are provided to introduce new features and fix bugs. Therefore, it is always a good idea to perform an available update.

---

At all heatcon! systems, which are not connected to the internet, we recommend to install available updates via USB stick.

OEM partners and specialist companies have access to the available update files via EbV - Support. The update files are encrypted and signed so that the security of your data and the system is always guaranteed. The system checks whether there is a suitable update file on the USB stick. This ensures that only suitable update files are installed. An exchange of the files (the USB update system is available for all heatcon! and heatapp! devices), e.g. by renaming, is therefore impossible.

### 7.3.1 Installation Updates via USB Stick

#### NOTE

---

- For the update via USB stick, use an empty USB memory stick with Fat32 formatting.
  - Before update, carry out a data backup in the System Management menu.
- 

Save the update file on the USB stick.

Plug the USB memory stick into the USB port of the heatcon! EC.

The LED signals the update process:

LED flashes cyan (blue)	Update file is read
LED static green or yellow	Update will be installed
LED 5 sec. red and then green	Update failed (e.g. becOffe wrong update file on the USB stick)
LED 5 sec. fuchsia (purple) then red	System is in recovery status

#### NOTE

---

Do not disconnect the power supply of the heatcon during the update! EC.

---

The actual update process takes between three and eight minutes. The USB memory stick can then be removed and the system can be set up or, if setup is already complete, normal operation can begin.

## 7.3.2 Assignment of the inputs and outputs

### 7.3.2.1 Overview

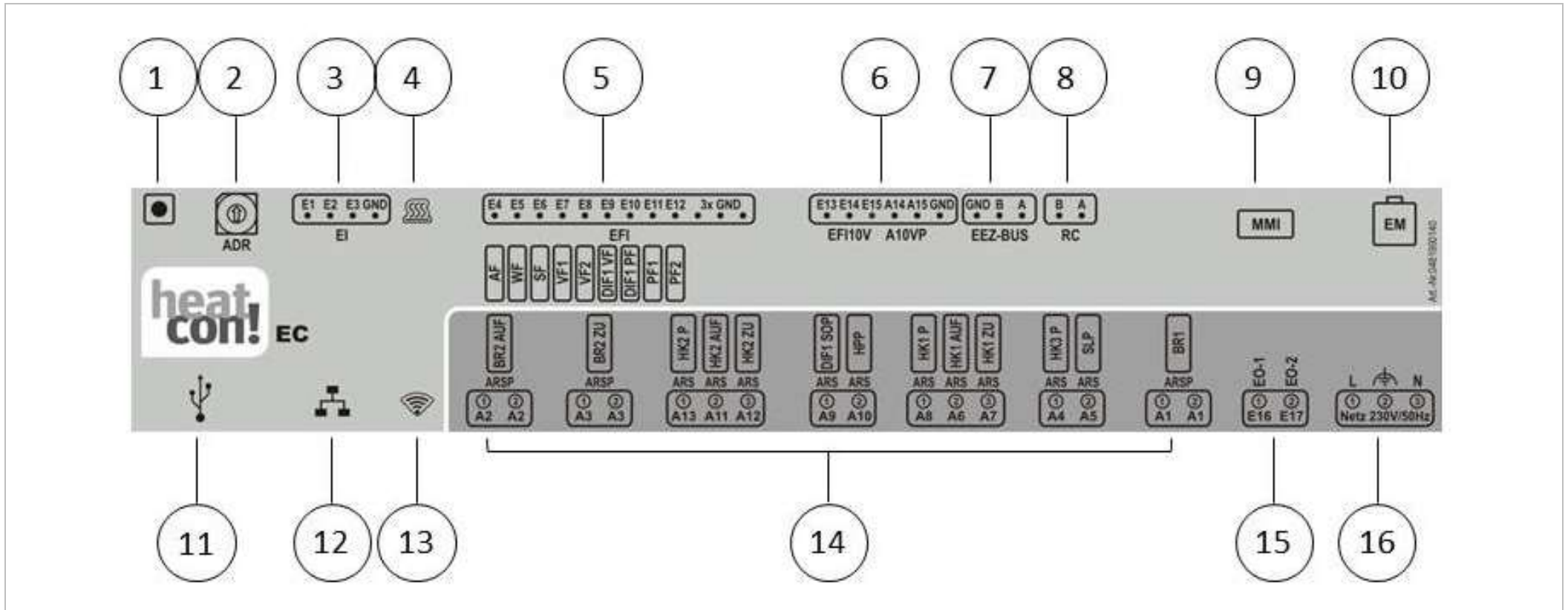

Fig. 27: heatcon! EC - connection assignment

1	Button	9	Connection <i>heatcon!</i> MMI
2	Address selector switch	10	EbV system bus for <i>heatcon!</i> EM
3	Digital inputs	11	USB connection
4	"Control" LED	12	Network connection (Ethernet, RJ45)
5	Temperature sensor inputs	13	"Network" LED
6	Analogue inputs/analogue outputs 0-10V	14	Digital outputs 230V AC
7	Energy generator bus	15	Digital inputs 230V AC
8	Two-wire bus h2B for room stations	16	Power supply

### 7.3.2.2 Energy generator 1

Individual setting	Configuration	Connections
Single-stage burner	Energy generator function ⇔ Single-stage burner	A1 ⇔ BR1 E5 ⇔ WF
Two-stage burner	Energy generator function ⇔ two-stage burner	A1 ⇔ BR1 A2 ⇔ BR2 AUF A3 ⇔ BR2 ZU E5 ⇔ WF
Power Signal on/off	Energy generator function ⇔ modulating OFF/ON	A1 ⇔ BR1 A2 ⇔ BR2 AUF A3 ⇔ BR2 ZU E5 ⇔ WF
Burner control system (OT/Bus)	Energy generator function ⇔ Control system	EEZ-Bus A/B
Temperatur signal 0-10V	Energy generator function ⇔ Actuator signal 0-10V	A14 ⇔ A10VP E5 ⇔ WF
Release contact	Energy generator function ⇔ Switchcontact	A1 ⇔ BR
Power signal 10V	Energy generator function ⇔ Modulating 10V	A1 ⇔ BR A14 ⇔ A10VP E5 ⇔ WF



### 7.3.2.3 Energy generator 2

Individual setting*	Configuration	Connections
Single-stage burner	Energy generator function ⇔ Single-stage burner	A2 ⇔ BR1 E13 ⇔ WF
Control system (OT/Bus)	Energy generator function ⇔ Automat	EEZ-Bus A/B
Temperatur signal 0-10V	Energy generator function ⇔ Temperatur signal 0-10V	A15 ⇔ A10VP
Release contact	Energy generator function ⇔ Release contact	A2 ⇔ BR
Power signal 0-10V	Energy generator function ⇔ Modulating 10V	A2 ⇔ BR A15 ⇔ A10VP E13 ⇔ WF
*Adjustability according to GEN1 occupancy		

### 7.3.2.4 Heating buffer

Individual setting	Configuration	Connections
Charge control	Heating buffer-function ⇔ Charge control	A10 ⇔ HPP E11 ⇔ PF1
Discharge control 1	Heating buffer-function ⇔ Discharge control 1	E11 ⇔ PF1
Discharge control 2	Heating buffer-function ⇔ Discharge control 2	E11 ⇔ PF1

### 7.3.2.5 Domestic hot water

Individual setting	Configuration	Connections
Storage pump	Hot water function ⇔ Storage pump	A5 ⇔ SLP E6 ⇔ SF
Circulation pump	Hot water function ⇔ circulation pump.	A5 ⇔ ZKP E6 ⇔ SF
Burner control system (OT/Bus)	Hot water function ⇔ Burner control system	EEZ-Bus A/B
Heating usage	Hot water function ⇔ Heating usage	A5 ⇔ ELH E6 ⇔ SF

### 7.3.2.6 Heating circuit 1

Individual setting	Configuration	Connections
Direct circuit	Heating circuit 1-function ⇔ Pump	A8 ⇔ HK1P
Mixing circuit	Heating circuit 1-function ⇔ Valve	A8 ⇔ HK1P A6 ⇔ HK1AUF A7 ⇔ HK1ZU E7 ⇔ VF1

### 7.3.2.7 Heating circuit 2

Individual setting	Configuration	Connections
Direct circuit	Heating circuit 2-function ⇔ Pump	A13 ⇔ HK2P
Mixing circuit	Heating circuit 2-function ⇔ Valve	A13 ⇔ HK2P A11 ⇔ HK2AUF A12 ⇔ HK2ZU E8 ⇔ VF2

### 7.3.2.8 Heating circuit 3

Individual setting	Configuration	Connections
Direct circuit	Heating circuit 3-function ⇔ Pump	A4 ⇔ HK3P

### 7.3.2.9 Differential control 1

Individual setting	Configuration	Connections
Solar	Difference 1 -function ⇔ Solar Flow sensor: E9:EFI DHW storage sensor: E10:EFI Pump Relais: A9:ARS	A9 ⇔ SOP E9 ⇔ DIF1:VF E10 ⇔ DIF1:PF
Solid fuel	Difference 1 -function ⇔ Solid fuel Flow sensor: E9:EFI Speicherfühler: E10:EFI Pump Relais: A9:ARS	A9 ⇔ FSP E9 ⇔ DIF1:VF E10 ⇔ DIF1:PF

Individual setting	Configuration	Connections
Difference	Difference 1 -function ⇒ Difference Flow sensor: E9:EFI DHW storage sensor: E10:EFI Pump Relais: A9:ARS	A9    ⇔    DIF1P E9    ⇔    DIF1:VF E10   ⇔    DIF1:PF

**NOTE**

---

As standard, temperature sensor input E9 is configured as the connection for PT1000 temperature sensors.

---

### 7.3.3 Setup wizard in heatcon! MMI and web browser

The Setup Wizard in the heatcon! Systems guides you through the basic settings of the system in just a few steps.

First decide whether the heatcon! EC is to be operated exclusively via the heatcon! MMI or whether a network and Internet connection is desired.

For the network connection, the heatcon! EC is connected to the router via a LAN cable. The initial setup is done via the internet browser of a PC/laptop/tablet or smartphone.

#### NOTE

---

No access data are adjusted via heatcon! MMI nor are any network settings made.

If operation is subsequently to take place via the heatapp! App, the first setup must be carried out using a PC/laptop.

#### Network

---

A functioning network in your house or flat is required for installation, an internet connection is not necessary.

If you do not have an internet connection, however, you can only operate heatcon! with your smartphone or tablet from home, not when you are on the move.

You will also not be able to download any updates for heatcon! We therefore strongly recommend connecting the heatcon! system to the internet.

---

Automatic address allocation (DHCP) must be enabled in the network settings of the PC/laptop and no proxy server must be enabled.

---

1. Switch on the power supply for the heatcon! EC.

#### Using the USB LAN adapter:

2. Connect the USB LAN adapter from the installation kit to the heatcon! EC and to the network connection on the PC / laptop:  
Insert the USB LAN adapter into the USB port on the heatcon! EC.

Start the PC/laptop. Connect the **USB LAN adapter** to the PC/laptop's network connection.

#### Using the heatapp! installation stick

3. Insert the heatapp! installation stick into the USB port on the heatcon! EC.  
The heatapp! installation stick provides its own WLAN network (network name: heatcon! EC[xxxxxx]). The last 6 digits of the MAC ID (see also the type plate of the heatcon! EC) are displayed in the square brackets.  
Start the PC / laptop or tablet / smartphone. Connect the device to the WLAN network 'heatcon! EC[xxxxxx]'.



Shortly thereafter, the set-up wizard starts automatically in the browser window of your device. If the set-up wizard does not start automatically, enter the address <http://10.0.0.1> in the address line of the Internet browser.



### Use host name of the heatcon! EC:

Use a PC / laptop that is on the same network as the heatcon! EC. Open the Internet browser and enter **heatapp-ec** in the address line and press the Enter key.

### NOTE

Host name resolution is supported by many routers, but not all. Depending on which router you are using, it may therefore happen that the setup wizard page or the menu of the heatcon! EC menu does not open even though you have entered the host name in the address line of the Internet browser. In this case, use the IP address of the heatcon! EC or the installation stick or kit to open the menu on the PC.

MMI	Hydraulic function	Internet browser on PC/laptop/tablet/smartphone
 	<p>After switching on the power supply, the assignment of the MMI to the heatcon! EC starts. By default, EC1 with address 0 is selected. After the assignment, the setup wizard starts automatically in heatcon! MMI.</p> <p>Press the rotary button to start the configuration.</p> <p><b>Select language</b></p> <ul style="list-style-type: none"><li>• DE = German</li><li>• GB = English</li><li>• FR = French</li><li>• IT = Italien</li><li>• NL = Dutch</li><li>• PL = Polish</li><li>• ES = Spain</li><li>• TR = Türkisch</li><li>• RU = Russian</li><li>• HR = Croatia</li></ul>	<p>Only available on MMI.</p> <p>The individual setting of the language is only carried out on the MMI. The browser language is automatically displayed in the web interface. If this is not available, English is displayed as the default language.</p>

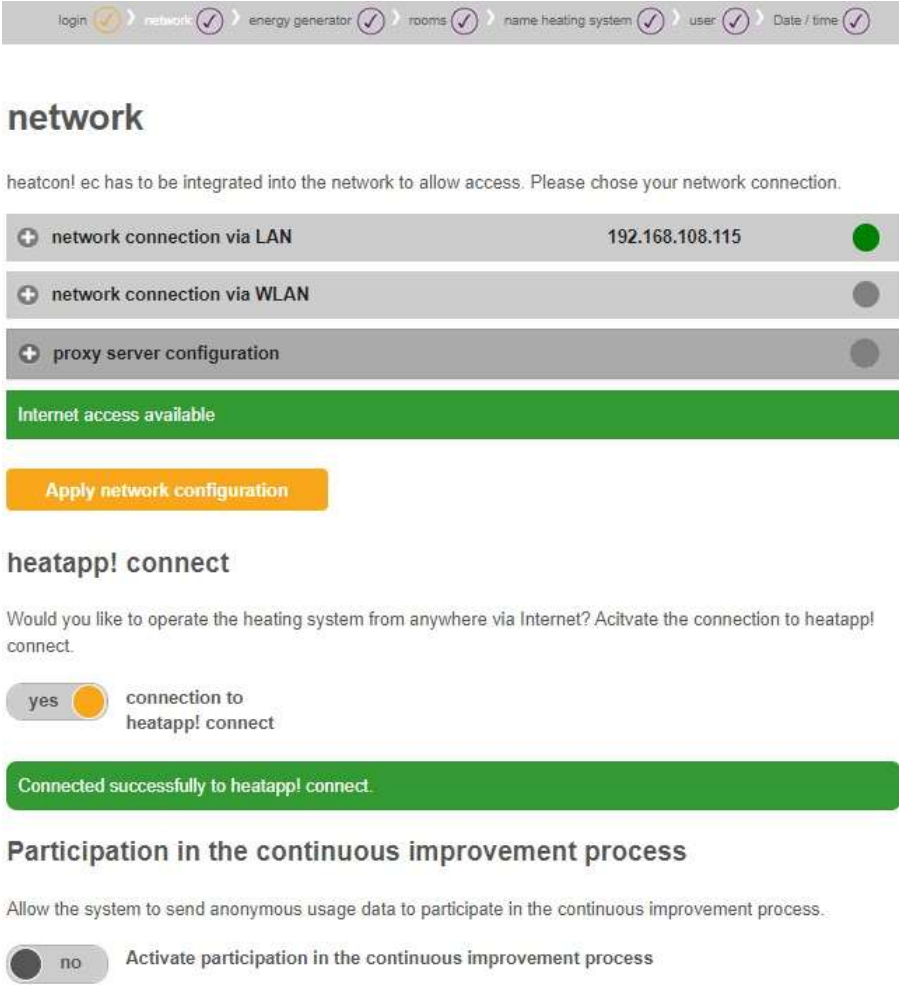
MMI	Hydraulic function	Internet browser on PC/laptop/tablet/smartphone
		
<p>Only available in web browser.</p>	<p><b>Creating a network connection</b></p> <ul style="list-style-type: none"> <li>• A LAN connection via DHCP is recommended (automatic setup of an Internet connection)</li> <li>• LAN connection with manual settings (optional)</li> <li>• Setup of a proxy connection (optional)</li> </ul> <p>After an Internet connection has been created, the <i>heatcon!</i> system checks if an update is available.</p> <ul style="list-style-type: none"> <li>• If a system update is available, an installation Request appears. If the update is not installed, an initial setup cannot be performed.</li> <li>• Connection to <i>heatapp! connect</i> for remote control of the <i>heatcon!</i> system. <i>heatapp! connect</i> is required so that the system can subsequently be operated via the app from any location.</li> </ul>	

## MMI



## Hydraulic function

### Energy generator 1-function

#### Setting options:

- OFF
- Single-stage burner
- Two-stage burner
- Power Signal on/off
- Control system
- Temperatur signal 0-10V
- Release contact
- Power signal 0-10V

### Energy generator 2-function

Select the energy generator 2 function.  
Availability depends on the setting of energy generator 1.

#### Setting options:

- Off
- Single-stage burner
- Control system
- Temperatur signal 0-10V
- Release contact
- Power signal 0-10V

### Heating buffer-function (buffer storage)

#### Setting options:

- Off
- Charge control
- Discharge control 1
- Discharge control 2

## Internet browser on PC/laptop/tablet/smartphone

**1 energy generator 1**  
select

Choose the type of the connected heat generator. Optional you can change the name.

type

name

- off
- single-stage burner
- two-stage burner
- power signal on/off
- burner control system (OT/Bus)
- temperature signal 10V
- release contact
- power signal 10V

**2 energy generator 2**  
select

Choose the type of the connected heat generator. Optional you can change the name.

type

name

- off
- single-stage burner
- burner control system (OT/Bus)
- temperature signal 10V
- release contact
- power signal 10V

**3 Heating buffer**  
Here you can activate a heating buffer

Select the mode of operation for the heating buffer.  
You can optionally assign a name.

type

name

- off
- charge control
- discharge control 1
- discharge control 2

ok

Wizard  
Hydraulic  
Hot water mode  
Function  
Off

Wizard  
Hydraulic  
Heating circuit  
Function  
Off

**Hot water heating****Setting options:**

- Off
- DHW-Storage pump
- DHW circulation pump
- Control system
- Heating usage

**Heating circuit 1...n****Setting options:**

- Off
- Direct circuit
- Mixing circuit  
(Nur bei HC 1 + 2, 4 + 5)

4

**domestic hot water**

Has the domestic hot water to be carried out by the system1

Please select the function for domestic hot water.

domestic hot water

off ▼

off

storage pump

circulation pump

heating usage

ok

5

**Heating circuit 1**

Setting of heat circuit 1

The heat circuit 1 can be activated as mixer unit or a direct heat circuit or can be deactivated.

heating circuit 1

name

off ▼

off

direct circuit

mixer circuit

ok

**NOTE**

Only the actual hardware heating circuits are automatically displayed in the setup wizard.

For mixed heating circuits, configure heating circuits 1+2, heating circuit 3 can only be used as an unmixed circuit.

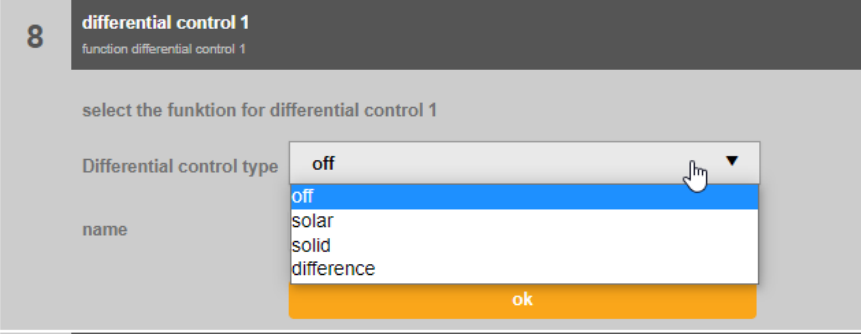
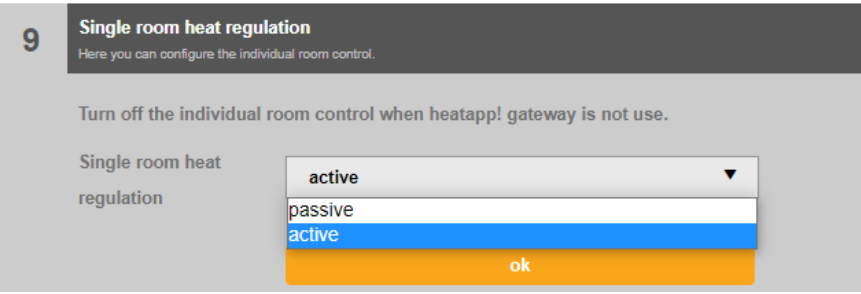

MMI	Hydraulic function	Internet browser on PC/laptop/tablet/smartphone
	<p><b>Differential control</b></p> <p><b>Setting options:</b></p> <ul style="list-style-type: none"> <li>• Off</li> <li>• Solar</li> <li>• Solid fuel</li> <li>• Difference</li> </ul>	
<p><i>Only available in web browser.</i></p>	<p><b>Single room control</b></p> <p>Select whether the connection to the single room control <i>heatapp!</i> is available.</p> <p>If "Off" is selected, a room group is automatically created for each activated heating circuit.</p> <p>If "On" is selected, all rooms to be controlled must be created.</p>	
<p><b>NOTE</b></p>		
<p><b>Without single room control heatapp!:</b></p> <p>A room group is created for each heating circuit. As with a single room control, all the data relevant to the room group such as temperatures, timer programs etc. can be individually adjusted for the room group and do not affect the entire system.</p> <p>The room group setting act immediately on the assigned heating circuit.</p> <p><b>With heatapp! single room control:</b></p> <p>Here you create all rooms that are to be regulated by <i>heatapp!</i> and assign the rooms to the room supply.</p> <p>The room supply controls at which point the requirement is created so that the room is supplied with the necessary heat.</p>		

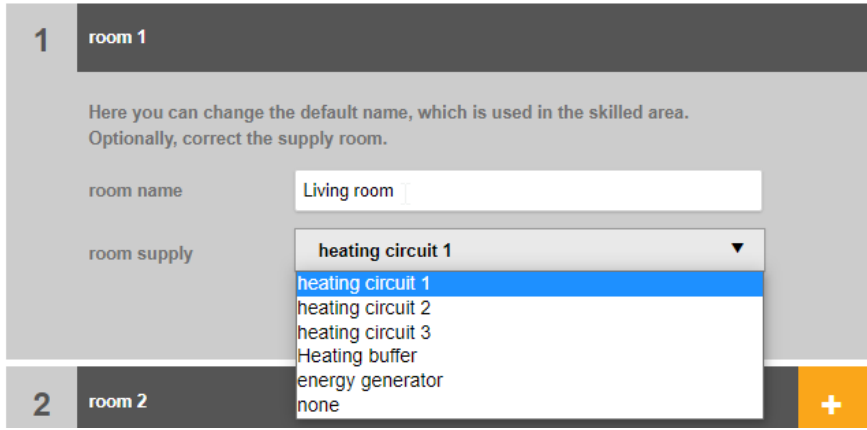
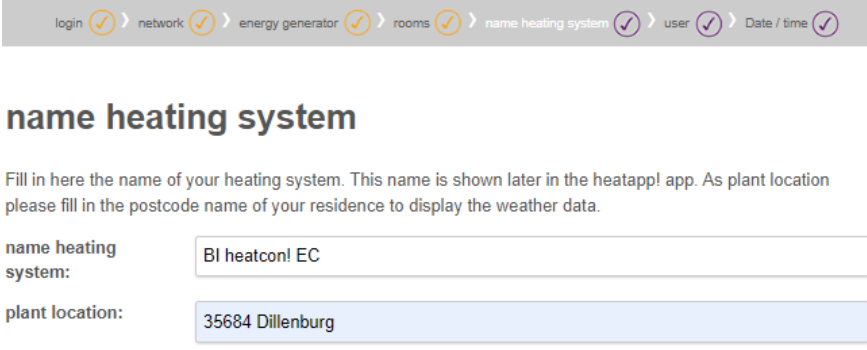
MMI	Hydraulic function	Internet browser on PC/laptop/tablet/smartphone
<p>Only available in web browser.</p>	<p><b>Rooms and room groups</b></p> <p>Single room control OFF = Displays the room groups of the activated heating circuits.</p> <p>Single room control ON = Create the rooms to be controlled and their room supply.</p>	
<p>Only available in web browser.</p>	<p><b>My system</b></p> <p>Allocate a name to your <i>heatcon!</i> system and enter the location (town and postcode). The entered location is used to display the weather data in the <i>heatapp! App</i>.</p>	

Only available in web browser.

### Users

To be able to operate the *heatcon!* system, the users must login to the system with username and password. Create at least two users with the following user roles:

- Expert for complete access to all settings
- Owner, for customisation and user management

Further users can be added later.

#### NOTE

The username must be at least 5 characters long. Allowed characters are upper case and lower case letters A-Z (a-z), special German characters äöüß, numbers 0-9 and special characters @- \_.

The password must contain at least 5 characters from two of the following character groups: Lower case letters, upper case letters, special characters, numbers.

#### ATTENTION

Use of the *heatcon!* system without access data is not possible either in the app or from a PC. Therefore, keep the access data somewhere safe.



### user

To use the heatapp! base, the user must with username and password to login. Register at least two users who have the roles:

- Expert, for full access to all settings
- Owner, for individualisation and user management

Additional users can be added to at a later date.

#### Caution:

Without login credentials is the use of the heatapp! base not possible!  
Keep the data.

+ Please create a new user.



1	<b>verwalter</b> Mr. Verwalter Verwalter user role: owner	>
2	<b>admin</b> Mr. Admin ADMIN user role: expert	>

1. Select the user role.
2. Enter first and last name of the user.
3. Enter the username.
4. Assign a password for the user.
5. Save the user by clicking on "Create".

Please create a new user. ✕

user role:

Please choose ▼

user name:

title:

Mr. ▼

password:

first name:

repeat your password:

name:

create

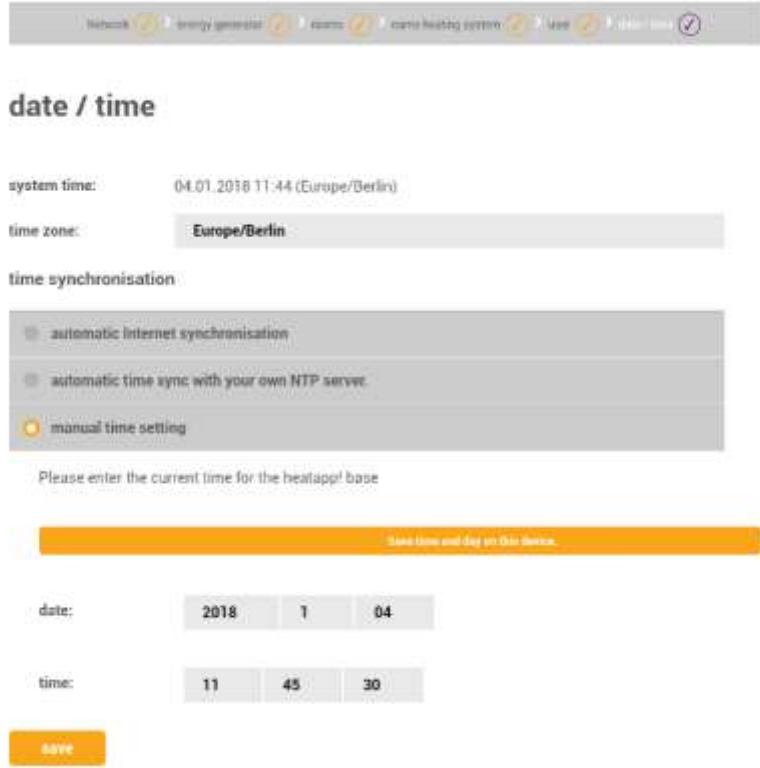
MMI	Hydraulic function	Internet browser on PC/laptop/tablet/smartphone
<p><i>Only available in web browser.</i></p>	<p><b>Date and time</b></p> <p>Here you select the time zone for your location (town of residence).</p> <p>You can select between the following variants:</p> <ul style="list-style-type: none"> <li>• Time synchronisation via the Internet</li> <li>• Time synchronisation via an internal NTP server</li> <li>• Manual time setting</li> </ul>	

Finished!

The initial setup of the heatcon! system is now complete. All parameters and temperatures are set to the basic settings. Further configuration takes place via the “Expert” menu.

The assignment of the electrical inputs and outputs corresponds to the tables in the chapter "Energy generator ", from page 64. Further configuration is carried out via the menu in the heatcon! MMI, see chapter "Menu overview", on page 47.

### 7.3.3.1 Establishment protocol

In the "Establishment protocol" area, a establishment protocol can be generated and sent by e-mail. The establishment protocol contains all information of your heatcon! configuration.

Generate Establishment protocol

- Tap on the "Generate a new establishment protocol" button to create a protocol.

The establishment protocol is stored in the heatcon! EC until a new one is build.

This allows you to access at the last establishment protocol at any time ("show establishment protocol" button) and/or send a PDF by e-mail ("Send establishment protocol" button).

Sending the establishment protocol by e-mail

1. Tap on the "Add a new e-mail address" button.
2. Enter the email address to which the establishment protocol is to be sent. You can enter multiple e-mail addresses.
3. Press the "Send establishment protocol" button to send the protocol.

If sending was successfull, a corresponding message is displayed.

Use the button  to return to the "System" menu.

## 7.4 Single room control heatapp!

If the selection "*Single room control - On*" was selected in the setup wizard, the *heatapp! gateway* and the *heatapp!* wireless components must now be set up.

Setup takes place according to the installation instructions which are supplied with the *heatapp! gateway* or according to the online instructions of the *heatapp!* system under <https://ebv-gmbh.eu/en/downloads/>.

The assignment of the electrical inputs and outputs corresponds to the list in the chapter "Energy generator 1", on page 64.

Further configuration is carried out via the "Expert" menu.

## 8 Parameter description

This section describes the menus and parameters of the *heatcon!* system. Depending on the system configuration, not all the menus and parameters are visible. The menus and parameters are accessible via the *heatcon!* MMI, *heatapp!* App and the PC user interface of the *heatcon!* EC PRO.

- The factory setting of the parameters is shown in **bold**.
- The "Access" column specifies the required access rights for the parameter:
  - **BE**: Operator/Owner
  - **HF**: Expert
  - **OEM**: OEM manufacturer

### 1.1 Calling the expert menu

#### 8.1.1 heatcon MMI

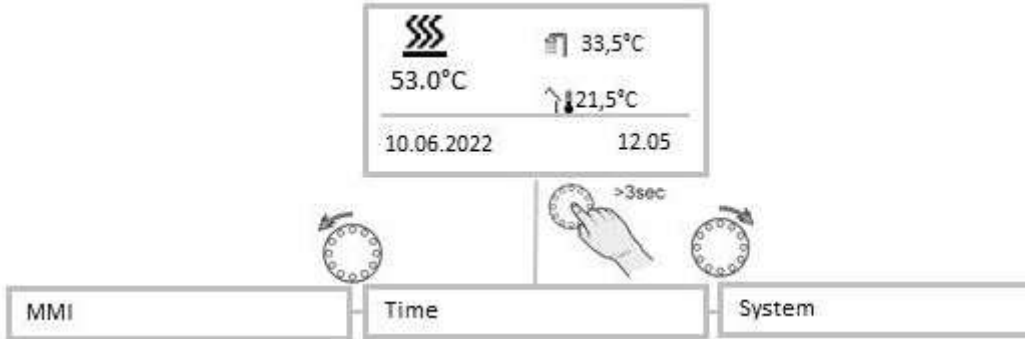
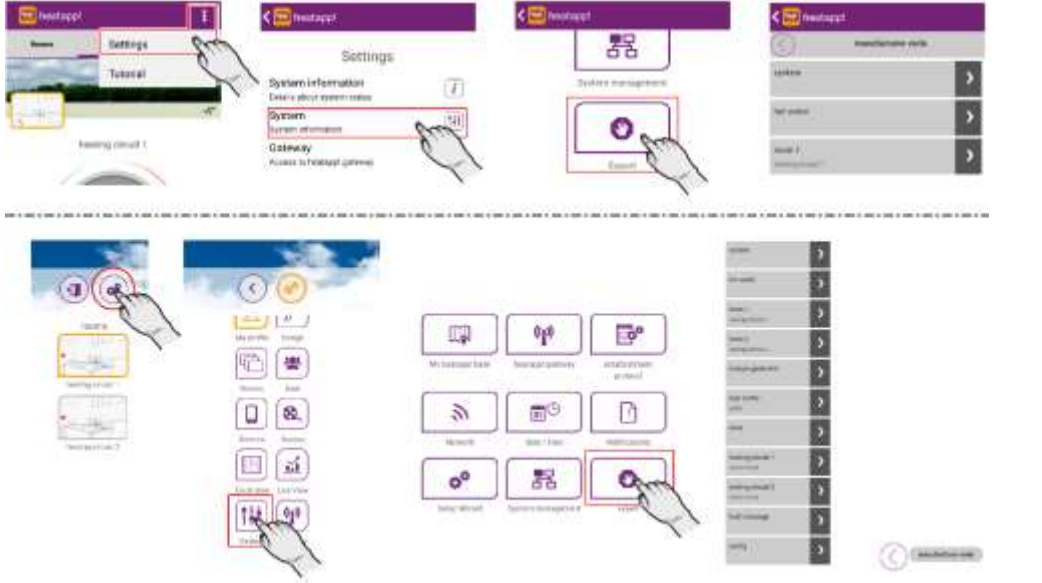
MMI	heatapp! App or Internetbrowser via PC
	 <p><b>NOTE</b></p> <p>The representation of the <i>heatapp!</i> app is a typical one. The representation may differ depending on the MMI device and operating system.</p>



PC **user** interface

1. Open an Internet browser on your PC.
2. Enter the IP address of the *heatcon! EC* in the address list of the Internet browser. You can determine the IP address of the *heatcon! EC* via the heatapp! app in the menu "*Settings/System/Network*" or via the HMI of your router.  
The PC user interface opens.
3. Click on the "*Expert*" button to call the Expert Menu.

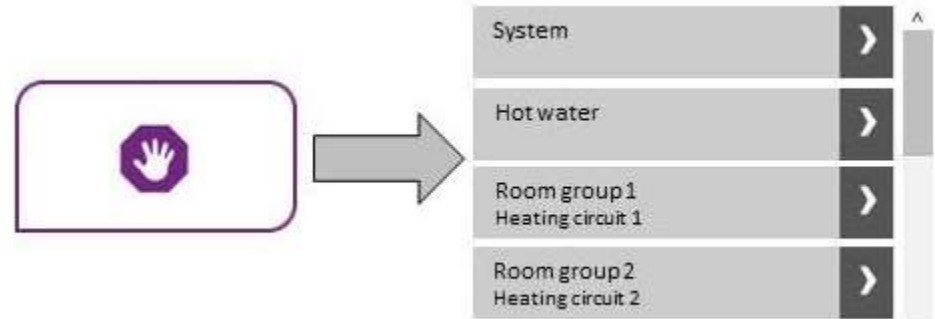
**NOTE**

The representation of the menu is a typical one. The representation may differ depending on the HMI device and operating system.

## 8.2 heatcon! MMI

The MMI system menus are described below. The factory setting of the parameters is shown in **bold**.

Menu / Parameter	Setting range	Description	Access
MMI			
Language selection	<b>DE</b> , GB, FR, IT, NL, PL, ES, TR , RU	MMI language selection <b>German</b> , English, French, Spanish, Turkish, Dutch, Italian, Russian... The language expansions of the <i>heatcon!</i> system are implemented via updates that are made available via the Internet. Therefore the list of languages is not complete.	BE
Fahrenheit	<b>Off</b> , On	Changeover of the temperature display into Fahrenheit	BE
Basic display 1	Off, 1...15 ( <b>1</b> )	Selection of the temperature values output to the basic display.	BE
Basic display 2	Off, 1...15 ( <b>2</b> )		
Basic display 3	Off, 1...15 ( <b>3</b> )		
Timeout	Off, 0,5 ... <b>2</b> ... 10,0 min	Time setting after which the MMI jumps back to the basic display	HF
LCD contrast	-10 ... <b>0</b> ... 10	Contrast setting for the LCD display on <i>heatcon! MMI</i>	BE
LCD brightness	0 ... <b>5</b> ... 10	Brightness setting of the background lighting for the LCD display on the <i>heatcon! MMI</i>	BE
MMI article number	–	Display of the article number of the <i>heatcon! MMI</i>	BE
Version	–	Display of the software version of the <i>heatcon! MMI</i>	BE
Access rights	0001 ... 9999	Code input for selection of access rights. <b>BE</b> User <b>HF</b> Expert (1234)	BE
Display module name	<b>Off</b> , On	Activate display of the individual default names. The default names are then displayed highlighted.	HF
Assignment	heatcon! 0 ... 5	Assignment of <i>heatcon! MMI</i> to the respective <i>heatcon EC</i>	HF
Reset	<b>Off</b> , Set	Resetting of the system to factory settings.	BE

Menu / Parameter	Setting range	Description	Access
Time			
Time	00:00 ... 23:59 Uhr	Setting of the system time	BE
Year	2013 ... 2099		
Month	1 ... 12		
DAY	1 ... 31		
CEST	OFF, On		

### 8.3 Menu – System

Menu / Parameter	Setting range	Description	Access
Expert / <b>System</b>			
Clima zone	Off, -20.0 ... <b>-12.0</b> ... 0.0 °C	Setting of the coldest anticipated outside temperature value. The value entered is included in the calculation of the Request value.	HF
Building	light, <b>medium</b> , heavy	Selection of the building type when using outside temperature control.	HF
Emergency mode temperature outside temperature	-50.0... <b>0.0</b> ...30.0°C	Outside temperature setting which is used for control after failure of the outside sensor.	HF
Cooling mode	On, <b>Off</b>	Enables or disables the cooling function for the system. X <sub>3</sub>	BE
Local operation	<b>On</b> , Off	Activation of the local software setting on the <i>heatapp! drive</i> . The setting is valid for all <i>heatapp! drives</i> registered on the <i>heatcon!</i> system. In room settings you can deactivate operation on the <i>heatapp! drive</i> for individual rooms.	BE
Battery status message	Off, 5 ... <b>10</b> ... 50 %	Switching threshold setting for the battery status message.	BE
Logical fault messages	<b>Off</b> , On	Activation of the logical fault messages. Logical fault messages evaluate the expected control result.	OEM
Error code machine	Off, interlock, blocking, <b>warning</b>	Selection of which fault messages of a machine are displayed and processed in the system (e.g. EO).	OEM
Code owner	0001...9999	Access code setting for the user levels.	OEM
Code expert			OEM
Code OEM			OEM
Colour symbols	Off, <b>On</b>	Activates the visual display "Heating active" in the <i>heatapp! APP</i>	HF
OEM factory values	Off, generate, reset, active	Generate OEM-specific factory values	OEM
Manual room cooling	Off, On	Enables the system parameter "cooling mode" X <sub>3</sub>	HF
Room Setpoint max	<b>Off</b> ... 0,0...5,0 K	System-wide limitation of the room Setpoint temperature	BE
Reset	<b>Off</b> , set	Resetting of the <i>heatcon!</i> parameters to the factory settings dependent on the access authorisation.	BE
X <sub>3</sub> Display only occurs if at least one <i>heatapp!</i> floor is integrated in the system.			

## 8.4 Menu – Domestic hot water (1) (2)

Menu / Parameter	Description	
Expert / Domestic hot water / <b>Information</b>		
Operation mode	Display of the current operation mode	
	Emission	Emission measurement program active
	Manual mode	System in manual mode
	Vacation	Vacation program active
	Reloading	Manual hot water reloading active
	Automatic	Operation according to switching time program is active
	Standby	Frost protection is switched off
	Release contact	Connected release contact closed
State	Display of the status	
	Emission	Emission measurement program active
	Manual mode	System in manual mode
	Forced draining	Active due to a forced draining function
	Setpoint	Setpoint is reached
	Heating	Hot water charging with Setpoint active
	Blocking	Hot water charging is blocked
	Setpoint reduction	Hot water Setpoint is reduced by differential control.
	Overrun time	Overrun time active
	Lead time	Pump lead time active
	stop	Discharge protection or boiler start-up protection active or advance operation of a second hot water tank
Setpoint	Display of the current Setpoint for hot water heating	
current temperature (1)	Display of the current temperature of the hot water storage	
current temperature2	Dis of the current temperature of the second hot water in stratified charge	
Pump	Display of the status of the DHW storage charging Pump	
Request	Display of the actual Setpoint temperature which is forwarded to the supply of the hot water heating (e.g. buffer Setpoint or energy generator Setpoint considering raising values)	

Menu / Parameter	Description
Expert / Domestic hot water / <b>Information</b>	
current temperature xx	Display of the actual temperature of the Requested source (heating buffer, energy generator)
Heating usage	Display of the status for the Heating usage (only with the Heating usage optional function)
Setpoint	Display of the current Setpoint, which is used for controlling the Heating usage (only with the Heating usage optional function)
Current temperature	Display of the actual temperature for the Heating usage (only with the Heating usage optional function)
DHW circulation pump	Display of the status of the DHW circulation pump (only with the DHW circulation pump optional function)
Setpoint	Setpoint from which the DHW circulation pump is switched on (only with the DHW circulation pump optional function)
current temperature (1)	Display of the current temperature of the DHW circulation pump sensor (only with the DHW circulation pump optional function)
current temperature2	Display of the current temperature of the second sensor of the DHW circulation pump (only with the DHW circulation pump optional function)
thermal power (thermal output)	Display of the current heating output in kW
Heat quantity	Display of the meter reading of the heat meter for the hot water storage in kWh.

Menu / Parameter	Setting range	Description	Access
Expert / Domestic hot water / <b>Timerprograms</b>			
Vacation	DD.MM ... DD:MM	Setting of the vacation period for hot water heating.	BE
Mo 1...3 Tu 1...3 ... Su 1...3	00:00 ... 24:00	Setting of the switching times for hot water heating.	BE

Menu / Parameter	Setting range	Description	Access
Expert / Domestic hot water / <b>Basic settings</b>			
Operation mode	Parallel, <b>priority</b> , conditional priority, weather conducted parallel operation, weather conducted parallel operation	Selection of the operation mode for hot water heating.	HF
Reloading	<b>Off</b> , 5 ... 240 min	Selection of the reloading time for hot water heating. Charging of hot water storage is activated for the set time.	BE
Shutdown	Room, <b>operation mode</b>	Selection, whether to switch off hot water heating based on the room setting or be setting the hot water operation mode.	HF
Switch contact	Off, standby, reduce, heating, frost protection	Selecting the property of the switching contact function (only if a switching contact input has been selected in the "Extras" menu)	HF
Name	Alphanumeric, maximum of 15 characters, no special characters	Entry of the name for the hot water function.	HF

Menu / Parameter	Setting range	Description	Access
Expert / Domestic hot water / <b>Heating mode</b>			
Day setpoint	Night setpoint(+0.5K) ... <b>50.0°C</b> ... Maximum temperature	Setting of the hot water setpoint temperature for heating operation.	BE
Night setpoint	5.5 ... <b>40.0°C</b> ... Day setpoint(-0.5K)	Setting of the hot water setpoint temperature for reduce mode.	BE
Switching difference	-30.0 ... <b>-2.5K</b> ... 30.0	Switching difference setting for hot water storage charging. Start charging: If actual temperature < setpoint - switching difference	HF
Hysteresis	1.0 ... <b>5.0K</b> ... 30.0	Hysteresis setting for hot water storage charging. End charging: If actual temperature > setpoint - switching difference + hysteresis	HF
Maximum temperature	20.0... <b>60.0°C</b> ... 80.0	Maximum temperature setting for the hot water storage.	HF
Increase of request	0.0 ... <b>20.0K</b> ... 50.0	Raising setting for forwarding the requirement to the energy source.	HF
Discharge protection	Off, <b>On</b>	With discharge protection activated and a DHW request present, the DHW loading pump is only enabled when the temperature in the energy generator rises by more than 5 K above the actual temperature in the hot water storage.	HF
Legionella protection day	<b>Off</b> , Mo ... Su, all	Selection of the day for legionella protection.	BE

Menu / Parameter	Setting range	Description	Access
Expert / Domestic hot water / <b>Heating mode</b>			
Legionella protection time	00:00 ... <b>2:00</b> ... 23:50 hour	Time setting for legionella protection.	BE
Legionella protection temperature	20.0 ... <b>60.0°C</b> ... Maximum temperature	Temperature setting for legionella protection.	HF
Legionella protection charging duration	Off, 5 ... <b>60 min</b> ... 240	Charging duration setting for legionella protection.	HF

Menu / Parameter	Setting range	Description	Access
Expert / Domestic hot water / <b>Pump</b>			
Lead time	<b>Off</b> , 0.5 ... 360 Min	Lead time setting of the charging Pump.	HF
Overrun time	<b>Off</b> , 0.5 ... 360 Min	Overrun time time setting of the charging Pump.	HF
Anti-lock system	<b>Off</b> , 5 ... <b>20</b> ... 300 sec	Runtime setting for the anti-lock protection of the charging Pump.	HF
Switch on mode	<b>Constant operation</b> , temperature spread, Setpoint	Operation mode selection for speed-control of the charging Pump.	HF
Interruption voltage	<b>Off</b> , 0.1 ... 10 V	Cut-off voltage setting of the charging Pump.	HF
Start time	<b>Off</b> , 1 ... <b>10</b> ... 240 sec	Start time setting of the charging Pump.	HF
Start output	0 ... <b>100 %</b>	Starting capacity setting of the charging Pump.	HF
Output	1 ... <b>100 %</b>	Capacity setting of the charging Pump.	HF
Minimum voltage	0.0 ... <b>5.0</b> ... 10 V	Minimum voltage setting of the charging Pump.	HF
Minimum output	0 ... <b>50</b> ... 100 %	Minimum capacity setting of the charging Pump.	HF
Maximum voltage	0.0 ... <b>10 V</b>	Maximum voltage setting of the charging Pump.	HF
Maximum output	0 ... <b>100 %</b>	Maximum capacity setting of the charging Pump.	HF
Regulation gain	1.0 ... <b>2.0</b> ... 50 %/K	Gain setting of the PID controller for the charging Pump.	HF
Regulation adjust time	1 ... <b>270</b> ... 600 sec	Reset time setting of the PID controller for the charging Pump.	HF
Regulation scan time	1 ... <b>20</b> ... 600 sec	Sample time setting of the PID controller for the charging Pump.	HF
Temperature spread	2.0 ... <b>10.0</b> ... 20.0K	Temperature spread setting for the "Temperature spread" switch-on type.	HF



Menu / Parameter	Setting range	Description	Access
Expert / Domestic hot water / Heating usage			
Summer operation mode	Off, -20.0 ... 30.0 °C	Outside temperature setting from which Heating usage activation should take place.	HF
Setpoint raise	-20.0 ... 0.0 ... 20.0 K	Setting for matching the hot water Setpoint with an active Heating usage.	HF

Menu / Parameter	Setting range	Description	Access
Expert / Domestic hot water / circulation pump			
Mode	Off, <b>time</b> , temperature, time and temperature	Selection of the operation mode for the DHW circulation pump.	HF
Period time	(Break time + 0.5) ... 15.0 ... 360 Min	Setting of the operating duration of the DHW circulation pump in the operation mode "time/time and temperature".	HF
Break time	Off, 0.0 ... 5.0 ... (Period time – 0.5 min)	Setting of the Break duration of the DHW circulation pump in the operation mode "time/time and temperature".	HF
Setpoint	5.0 ... 35.0 ... 80.0 °C	Setting of the switch on temperature of the circulation pump in the operation mode "temperature/time and temperature" if only one sensor has been configured.	HF
Hysteresis	1.0 ... 5.0 ... 10.0 K	Setting of the temperature hysteresis of the circulation pump in the operation mode "temperature/time and temperature" if two sensors have been configured.	HF
Switching difference	1.0 ... 5.0 ... 30.0 K	Setting of the temperature Switch-off difference of the DHW circulation pump in the operation mode "temperature/time and temperature" if one or two sensors have been configured.	HF
Anti-lock system	Off, 5 ... 20 ... 300 sec	Interval setting for the anti-lock protection of the DHW circulation pump.	HF

Menu / Parameter	Setting range	Description	Access
Expert / Domestic hot water / Heat balance			
Volume flow	Off, 0.5 ... 300 L/min or L/pulse	Setting of the volume flow for heat consumption measurement or setting of the units for pulse input of a flowmeter.	HF
Medium density	0.8 ... 1.05 ... 1.2 kg/L	Density setting of the heat transfer medium for heat consumption measurement.	HF
Medium heat capacity	1.0 ... 3.6 ... 50 kJ/kg*K	Heat capacity setting of the heat transfer medium for heat consumption measurement.	HF

Menu / Parameter	Setting range	Description	Access
Expert / Domestic hot water / <b>Heat balance</b>			
Reset	<b>Off</b> , set	Resetting of the meter for heat consumption measurement.	HF

Menu / Parameter	Setting range	Description	Access
Expert / Domestic hot water / <b>Reset</b>			
Reset	<b>Off</b> , set	Resetting of the parameters in the “Hot Water” menu to factory presets, dependent on access rights	BE

## 8.5 Menu – Room 1 ... n / Room group 1 ... n

Menu / Parameter	Description
Expert / Room 1... 24 / <b>Information</b>	
Expert / Room group 1 ... n / <b>Information</b>	
Operation mode	Display of the current operation mode.
Absent	"Absent" operation mode/scene active
Automatic	Operation according to switching time program is active
Emission	Emission measurement active
Screed	Screed drying program active
Manual mode	Manual mode active
Runtime Magic Wand	Manual temperature specification via magic wand function is active
Reloading	Room active for an activated hot water reloading (only with single room control)
Party	"Party" operation mode/scene active
Standby	"Standby" operation mode/scene active, frost protected room/room group switched off
Vacation	"Vacation" operation mode/scene active, frost protected room/room group switched off
Release contact	Connected switching contact closed
State	Display of the current status
Anti-lock system	Anti-lock system active for the actuators in the room (only with single room control)
Heating	Regulation to comfort or economy temperature
Heat limit	Switching off via heating limits function
Room blocking	Room not active due to exceeding the set limit temperature (only in connection with a room sensor)
Frost protection	Frost-protected room switched off
Summer	Room out of operation due to summer economy control
Off	Room not active (e.g. in automatic mode setback phases)
Setpoint	Display of the current Setpoint for the room temperature.
Current temperature	Display of the current temperature of the room (only if room temperature measurement is active).
Outside temperature	Display of the current outside temperature that is used for room control.

Menu / Parameter	Description
Expert / Room 1... 24 / <b>Information</b>	
Expert / Room group 1 ... n / <b>Information</b>	
Outside temperature long-term	Display of the long-term outside temperature value. This value is determined on the basis of the selected building type (System menu).
State valve 1 ... 4	Indication of the current position of a valve (drive or floor) under single room control.
Request	Display of the actual Setpoint temperature which is forwarded to the supply of the hot water heating (e.g. heating circuit Setpoint taking into account raising values).
Heating circuit xx	Display of the current temperature of the requested heating circuit.

Menu / Parameter	Setting range	Description	Access
Expert / Room 1... 24 / <b>Timerprograms</b>			
Expert / Room group 1 ... n / <b>Timerprograms</b>			
Vacation	DD:MM ... DD:MM	Vacation period setting for the room/room group.	BE
Mo 1...3 Tu 1...3 ... Su 1...3	00:00 ... 24:00 <b>06:00 ... 22:00</b>	Setting of the switching times for the room/room group.	BE

Menu / Parameter	Setting range	Description	Access
Expert / Room 1... 24 / <b>Basic settings</b>			
Expert / Roomgroup 1 ... n / <b>Basic settings</b>			
Request	<b>Outside temperature control,</b> room control, constant control	Selection of the requirement for the room/room group.	HF
Screed	<b>Off,</b> functional heating, laying heating, functional and laying heating, manuel	Selection of the screed heating program for the room/room group.	HF
Outside sensor mapping	<b>Outside temperature 1,</b> Outside temperature 2, average value outside sensor 1 and outside sensor 2	Selection of the corresponding outside sensor for the room/room group, if a second outside sensor has been configured.	HF

Menu / Parameter	Setting range	Description	Access
Expert / Room 1... 24 / <b>Basic settings</b>			
Expert / Roomgroup 1 ... n / <b>Basic settings</b>			
Frost protection	Off, -20 ... <b>3</b> ... 29 °C (or summer operation mode)	Outside temperature setting for activation of the frost protection function for the room/room group.	HF
Summer operation mode	Off, frost protection ... <b>20.0</b> ... 30 °C	Outside temperature setting for activation of summer Operation mode for the room/room group.	HF
Room blocking	<b>Off</b> , 0,1 ... 5 K	Setting for the room temperature raising value above which a requirement sent to the energy generator is discarded.	HF
Room thermostat	<b>Off</b> , 0,1 ... 5 K	Setting for the room temperature raising value above which the valves of the zones controlled by <i>heatapp!</i> floor are to be closed.	HF
Frost protection mode	Frost protection temperature, set-back temperature	Selection of the temperature level based on which the frost protection function for the room/room group is to be controlled. Room frost protection deviation control based on the set frost protection temperature or room frost protection deviation control based on the set set-back temperature.	HF
Runtime Magic Wand	Off, 0,5 ... <b>3,0</b> ... 12,0 h	Setting of the minimum runtime of the "Magic Wand function" for the temporary modification of the target temperature for the room/room group.	HF
Switch contact	<b>Off</b> , standby, reduce, heating, frost protection	Selecting the property of the switching contact function (only if a switching contact input has been selected in the "Extras" menu)	HF
Name	Alphanumeric, maximum of 15 characters, no special characters	Entry of the name for the room/room group.	BE

Menu / Parameter	Setting range	Description	Access
Expert / Room 1... 24 / <b>Room settings</b>			
Expert / Room group 1 ... n / <b>Room settings</b>			
Maximum temperature	comfort temperature ... <b>28,0 °C</b>	Setting the maximum room Setpoint temperature for the room	
Comfort temperature	Economy temperature ... <b>21.0</b> ... 28.0 °C	Room Setpoint temperature setting for heating operation.	BE
Economy temperature	Set-back temperature ... <b>20.0 °C</b> ... Comfort temperature	Setting of the reduced room Setpoint temperature for heating operation.	BE

Menu / Parameter	Setting range	Description	Access
Expert / Room 1... 24 / <b>Room settings</b>			
Expert / Room group 1 ... n / <b>Room settings</b>			
Set-back temperature	Frost protection temperature ... <b>18.0 °C</b> ... Economy temperature	Room Setpoint temperature setting for setback operation.	BE
Frost protection temperature	4.0 ... <b>16.0 °C</b> ... Set-back temperature	Room Setpoint temperature setting for frost protection operation.	BE
Switch on optimisation	<b>Off</b> , 0.5 ... 8.0 h	Start time advance setting dependent on the outside temperature.	HF
Boost-Offset	0.5 ... <b>2.0</b> ... 5.0 K	Increase setting of the room Setpoint temperature if Boost scene is activated in the <i>heatapp! App</i> .	BE
Local operation	<b>Off</b> , On	Activation of the local software setting on the <i>heatapp! drive</i> , only for this room.	BE
Window shutdown	<b>Off</b> , 5 ...240 Min, On	5 ... 240 Min: Blocking of the heating function (regulation to the frost protection temperature) for the set duration. Rotary wheel is disabled, scenes only work after window is closed. On: Disabling of the heating function for the duration of window opening. Rotary wheel is disabled, scenes only work after window is closed.	BE

Menu / Parameter	Setting range	Description	Access
Expert / Room 1... 24 / <b>Heating mode</b>			
Expert / Room group 1 ... n / <b>Heating mode</b>			
Lowering mode (set-back mode)	Standby, heating	Selection of the operation mode for setback operation. Frost protected switch-off (standby) or set set-back temperature (heating)	BE
Room factor	<b>Off</b> , 5 ... 100 ... 500 %	Room factor setting (room temperature influence).	HF
Frost protection cycle	<b>Off</b> , 0.5 ... 360.0 Min	Selection of the operation mode for the frost protection function for the room/room group. Off: Permanent system frost protection, Time: Cycle time of the system frost protection	HF
Heating curve	<b>Off</b> , 0.5 ... 3.5	Steepness setting of the heating curve with outside temperature control.	HF
Heating system	<b>1.0</b> ... 10.0	Standard values for setting: Underfloor heating system: 1.10; Radiator: 1.30; Convector:1.40; Air conditioning >2.00	HF
Adaptation	<b>Off</b> , On	Activation of the automatic parameter adaptation for the heating curve.	HF
Heat limit	<b>Off</b> , 0.5 ... 40 K	Heat limit setting for the room.	HF

Menu / Parameter	Setting range	Description	Access
Expert / Room 1... 24 / Heating mode			
Expert / Room group 1 ... n / Heating mode			
Increase of Request	-5.0 ... <b>0.0</b> ... 20 K	Requirement-boost setting for the room. Increase to the Setpoint for passing on to the heating circuit.	HF
Regulation gain	1.0 ... <b>8.0</b> ... 100 %/K	Gain setting for the PI controller for single room control.	HF
Regulation adjust time	5 ... <b>15</b> ... 240 Min	Reset time setting for the PI controller of the single room control.	HF
Regulation scan time	1 ... <b>20</b> ... 30 Min	Sample time setting for the PI controller for single room control.	HF

Menu / Parameter	Setting range	Description	Access
Expert / Room 1... 24 / cooling mode			
Expert / Room group 1 ... n / cooling mode			
Cooling release	<b>Off</b> , On	If the cooling diverter valve is parametrised and cooling supply is possible for the heating circuit, cooling enable for the room or room group can occur here. OR If "Manual room cooling" is activated and a heatapp! floor is assigned to the room, you can define the cooling release for the room or room group here.	HF
room thermostat	Off, <b>0,1K</b> ... 5,0K	Off: Cooling is not switched off above Setpoint temperature < actual temperature. 0.1 K ... 5.0 K: Setting of the point at which the system stops cooling when the room temperature falls below the Setpoint temperature.	
Room factor	Off, 5, 10 ... <b>100</b> ... 500%	If a room sensor is being used, the room factor can be used to set the influence of the room temperature on the Setpoint calculation.	HF
Setpoint reduction	-15K, -14,5 ... <b>0 K</b>	Reduction of the requirement by the amount set here.	OEM
Characteristic map outside minimum	<b>15.0</b> ... 45.0°C	Configuration of characteristic map cooling mode	HF
Characteristic map outside maximum	15.0... <b>24.0</b> ... 45.0°C	Configuration of characteristic map cooling mode	HF
Characteristic map Flow-minimum	7.0... <b>18.0</b> ... 30.0°C	Configuration of characteristic map cooling mode	HF
Characteristic map Flow-maximum	7.0... <b>24.0</b> ... 30.0°C	Configuration of characteristic map cooling mode	HF

Menu / Parameter	Setting range	Description	Access
Expert / Room 1... 24 / <b>cooling mode</b>			
Expert / Room group 1 ... n / <b>cooling mode</b>			
Characteristic map room minimum	15.0... <b>22.0</b> ... 30.0°C	Configuration of characteristic map cooling mode	HF
Characteristic maproom maximum	15.0... <b>25.0</b> ... 30.0°C	Configuration of characteristic map cooling mode	HF
Increase of Request	-5.0... <b>0.0</b> ... 20.0K	Setting of the requirement increase for the room. Increase to the Setpoint for transfer to the cooling circuit.	HF

Menu / Parameter	Setting range	Description	Access
Expert / Room 1... 24 / <b>Screed</b>			
Expert / Room group 1 ... n / <b>Screed</b>			
Temperature day 1 ... 30	15.0° C ... 65.0° C	Setting the temperature for the manual screed function. The preset temperature values are identical to the function "Functional and laying heating". By entering a temperature value for day 26, the menu expands to day 27, etc.	HF

Menu / Parameter	Setting range	Description	Access
Expert / Room 1... 24 / <b>Reset</b>			
Expert / Room group 1 ... n / <b>Reset</b>			
Reset	<b>Off, set</b>	Resetting of the parameters in the "Room group/ heating circuit" menu to factory presets, dependent on access rights.	BE



## 8.6 Menu – Heating circuit

Menu / Parameter	Description	
Expert / Heating circuit 1 ... n / <b>Information</b>		
State	Display of the current state	
	Anti-lock system	Anti-lock system Anti-lock system for the actuators
	Heating	Control to comfort- or economy temperature
	Priority	Heating circuit is switched off by DHW priority
	Heat limit	Switch-off via functional heating limit
	Frost protection	Heating circuit switched off frost-protected
	Summer	Heating circuit out of operation due to summer switch-off
	Off	Heating circuit not active (e.g. in setback phases automatic
Setpoint	Display of the current Setpoint of the heating circuit.	
Current temperature	Display of the current heating circuit flow temperature (mixed heating circuit only).	
Pump	State of heating circuit Pump on/off	
Mixing valve	Calculated position of the actuator	
Request	Display of the current Setpoint temperature which is passed on for supply (e.g. heating circuit Setpoint taking into account excessive values).	
Energy generator	Display of the actual temperature GEN at supply to the energy generator.	
Heating buffer	Display of the actual temperature heating buffer with heating buffer supply.	

Menu / Parameter	Setting range	Description	Access
Expert / Heating circuit 1 ... n / <b>Basic settings</b>			
Name	Alphanumeric, maximum of 15 characters, no special characters	Entry of the name for the heating circuit	HF

Menu / Parameter	Setting range	Description	Access
Expert / Heating circuit 1 ... n / Heating mode			
Minimum temperature	OFF, 10 ... <b>20°C</b> ... Minimum-temperature	Minimum temperature limit	HF
Maximum temperature	OFF, Minimum-temperature ... <b>45°C</b> ... 95°C	Maximum temperature limit	HF
Increase of Request	-5,0 ... <b>0,0</b> ... 20 K	Setting of the increase of request to the setpoint for transfer to the energy supplier (GEN or buffer).	HF
Return flow limitation	<b>OFF</b> , 10 ... 95°C	Limitation value for configured return flow limitation.	HF

Menu / Parameter	Setting range	Description	Access
Expert / Heating circuit 1 ... n / Cooling mode			
Minimum temperature	OFF, 10 ... <b>18°C</b> ... Minimum-temperature	Minimum temperature limit	HF
Maximum temperature	OFF, Minimum-temperature ... <b>21°C</b> ... 95°C	Maximum temperature limit	HF
Increase of Request	-5,0 ... <b>0,0</b> ... 20 K	Setting of the increase of request to the setpoint for transfer to the energy supplier (GEN or buffer).	HF

Menu / Parameter	Setting range	Description	Access
Expert / Heating circuit / Pump			
Lead time	<b>Off</b> , 0,5 ... 360 min	Setting the lead time of the heating circuit Pump.	HF
Overrun time	<b>Off</b> , 0,5 ... 360 min	Setting the run-after time of the heating circuit Pump.	HF
Anti-lock system	Off, 5 ... <b>20</b> ... 300 sec	Setting the running time for the anti-lock protection of the heating circuit Pump.	HF
Switch on mode	<b>Constant mode</b> , Temperature spread, Setpoint	Selection of the operation mode for the speed control of the heating circuit Pump.	HF
Interrupting voltage	<b>Off</b> , 0,1 ... 10 V	Setting of the interruption voltage of the heating circuit Pump.	HF
Start time	Off, 1 ... <b>10</b> ... 240 sec	Setting the start time of the heating circuit Pump.	HF
Start output	0 ... <b>100 %</b>	Setting the starting output of the heating circuit Pump.	HF
Output	1 ... <b>100 %</b>	Setting the output of the heating circuit Pump	HF

Menu / Parameter	Setting range	Description	Access
Expert / Heating circuit / <b>Pump</b>			
		(with switch-on mode constant operation)	
Minimum voltage	0,0 ... <b>5,0</b> ... 10 V	Setting of the minimum voltage of the heating circuit Pump.	HF
Minimum output	0 ... <b>50</b> ... 100 %	Setting of the minimum output of the heating circuit Pump.	HF
Maximum voltage	0,0 ... <b>10 V</b>	Setting of the maximum voltage of the heating circuit Pump.	HF
Maximum output	0 ... <b>100</b> %	Setting of the maximum output of the heating circuit Pump.	HF
Regulation gain	1,0 ... <b>2,0</b> ... 50 %/K	Setting the gain of the PID controller for the heating circuit Pump.	HF
Regulation adjust time	1 ... <b>270</b> ... 600 sec	Setting the adjust time of the PID controller for the heating circuit Pump.	HF
Regulation scan time	1 ... <b>20</b> ... 600 sec	Setting the scanning time of the PID controller for the heating circuit Pump.	HF
Temperature spread	2,0 ... <b>10,0</b> ... 20,0K	Setting of the temperature spread for the "Temperature spread" switch-on mode.	HF

Menu / Parameter	Setting range	Description	Access
Expert / Heating circuit 1 ... n / <b>Mixing valve</b>			
Regulation gain	1,0 ... <b>2,0</b> ... 50 %/K	Setting the gain of the PID controller for the heating circuit Pump.	HF
Regulation adjust time	1 ... <b>270</b> ... 600 sec	Setting the adjust time of the PID controller for the heating circuit Pump.	HF
Regulation scan time	1 ... <b>20</b> ... 600 sec	Setting the scanning time of the PID controller for the heating circuit Pump.	HF
Runtime	1 ... <b>120</b> ... 600 sec	Actuator running time	HF
Stop position deactivation	<b>OFF</b> , on	Valve stop position control	HF
Anti-lock system	OFF, 1 ... <b>20</b> ... 300 sec	Setting the running time for the anti-lock protection of the mixing valve	HF

Menu / Parameter	Setting range	Description	Access
Expert / Heating circuit 1 ... n / <b>Heat balance</b>			
Volume flow	<b>Off</b> , 0,5 ... 300 L/Min or L/pulse	Setting the flow rate for heat balancing or setting the unit for the pulse input of a flow meter.	HF
Medium density	0,8 ... <b>1,05</b> ... 1,2 kg/L	Setting the density of the heat transfer medium for heat balancing.	HF
Medium heat capacity	1,0 ... <b>3,6</b> ... 50 kJ/kg*K	Setting the heat capacity of the heat transfer medium for heat balancing.	HF
Reset	Off, Set	Resetting the meter for heat balancing.	HF

Menu / Parameter	Setting range	Description	Access
Expert / Heating circuit n / <b>Reset</b>			
Reset	Off, Set	Reset the parameters in the menu " Heating circuit " to factory settings according to the access authorization.	HF

## 8.7 Menu - Total flow

Menu / Parameters	Description
Expert / Total flow / <b>Information</b>	
State	Display of the current state
Setpoint temperature	Display of the setpoint total flow
Current temperature	Display of the current actual value of the total flow temperature
Request	Request PI control
Mixing valve	Calculated position of the actuator
Setpoint temperature	Setpoint temperature valve
Current temperature	Current temperature valve

Menu / Parameters	Adjustment range	Description	Access
Expert / Total flow / <b>setpoint</b>			
Mode	All, Heating circuit, Hot water, <b>Heating</b> , Cooling	Operating mode	HF
Regulation gain	1,0 ... <b>2,0</b> ... 50 %/K	Setting of the gain of the PID controller for the total flow control.	HF
Regulation adjust time	1 ... <b>270</b> ... 600 sec	Setting of the adjust time of the PID controller for the total flow control.	HF
Regulation scan time	1 ... <b>20</b> ... 600 sec	Setting of the scan time of the PID controller for the total flow control.	HF
Minimum temperature	5 ... <b>20</b> ... 95°C	Minimum temperature	HF
Maximum temperature	5 ... <b>80</b> ... 95°C	Maximum temperature	HF

Menu / Parameters	Adjustment range	Description	Access
Professional / Total flow / <b>Mixing valve</b>			
Regulation gain	1,0 ... <b>2,0</b> ... 50 %/K	Setting the gain of the PID controller for the mixing valve.	HF
Regulation adjust time	1 ... <b>270</b> ... 600 sec	Setting the adjust time of the PID controller for the mixing valve.	HF
Regulation scan time	1 ... <b>20</b> ... 600 sec	Setting the scan time of the PID controller for the mixing valve.	HF
Runtime	1 ... <b>120</b> ... 600 sec	Running time actuator	HF

Menu / Parameters	Adjustment range	Description	Access
Stop position deactivation	<b>OFF</b> , ON	Valve end position control	HF
Anti-lock system	OFF, 1 ... <b>20</b> ... 300 sec	Setting the running time for the anti-blocking protection of the mixing valve	HF

Menu / Parameters	Adjustment range	Description	Access
<b>Pro / Total flow/ Reset</b>			
Reset	<b>Off</b> , Run	Resetting the parameters in the "Total flow" menu to the factory setting according to the access authorisation.	HF

## 8.8 Menu – Cascade

Menu / Parameter	Description	
Expert / Cascade / Information		
Heating mode	Setpoint heating circuit	
Cooling mode	Setpoint cooling circuit	
Hot water mode	Setpoint hot water circuit	
current temperature	Temperature value of the control stage or total flow	
Cascade boiler-INFO	Current Operation mode:	
	n	Number of position in cascade manager
	EC n	EC number of the energy generator
	GEN n	GEN Number of the energy generator
	x°C	Current Setpoint temperature
... Request	OFF	No Request
	OFF	Level is locked
	HZ	Heating mode
	WW	Hot water mode
	KU	Cooling mode
	(n)	Priority level locked
State	:	No Request
	=	Management level
	>	Base load
	<	Minimum temperature
	-	Emission mode
	#	Manual mode
	x°C	Current temperature
	*	Burner state (flame)
	%	Output limit activ

Menu / Parameter	Setting range	Description	Access
Expert / Cascade / <b>Basic settings</b>			
Control level	Level 1...n (available)		HF
Control level changeover	Off 1h ... 720h	Advancing the control stage	HF

Menu / Parameter	Setting range	Description	Access
Expert / Cascade / <b>Reset</b>			
Reset	Off, set	Reset the parameters in the "Cascade" menu to the factory settings according to the access authorization.	BE



## 8.9 Menu – Energy generator -1 or 2

Menu / Parameter	Description	
Expert / Energy generator 1 or 2 / <b>Information</b>		
State	Display of the status of the energy generator (GEN)	
	Heating	GEN serves Request for heating operation
	Heating	GEN serves Request for hot water operation
	Emission	GEN emission measurement active
	SLT	Safety temperature limiter (SLT) triggered
	Manual mode	GEN manual mode active
	Frost protection	GEN serves Request for frost protection function
	Blocking	GEN blocked by blocking contact
	Overrun time	GEN overrun time time active
	Start protection	GEN start-up protection active
	Outside temperature barrier	Summer or winter block active
	Off	GEN switched off
Level	Display of the status of the energy generator (GEN)	
	On	GEN active
	Off	GEN not active
	xx%	Display of the actual output with a modulating GEN
	Outside temperature barrier	Outside temperature block active for GEN
Setpoint	Display of the current Setpoint for the energy generator.	
current temperature (1)	Display of the current temperature of the energy generator.	
current temperature (2)	Dis of the current temperature of the energy generator at the second sensor.	
Exhaust gas sensor	Display of the current flue gas temperature.	
Pump	Display of the status of the Pump in the energy generator (e.g. boiler Pump)	
Burner starts	Display of the number of burner starts.	
Burner runtime	Display of the burner runtime.	

Menu / Parameter	Description
Expert / Energy generator 1 or 2 / <b>Information</b>	
thermal power (thermal output)	Display of the current heating output of the energy generator.
Heat quantity	Actual meter value of the energy generator heat meter.

Menu / Parameter	Setting range	Description	Access
Expert / Energy generator / <b>Service</b>			
Manual mode	<b>Off</b> , minimum temperature ... Maximum temperature	Activation of manual mode for the energy generator.	BE
Reset counter	<b>Off</b> , set	Resetting of the energy generator meter (burner starts, burner runtime, heat quantity).	BE

Menu / Parameter	Setting range	Description	Access
Expert / Energy generator 1 or 2 / <b>Basic settings</b>			
Forced draining	<b>Off</b> , hot water, heating circuit, heating buffer, external	Selection of the type of forced draining for the energy generator.	HF
Forced draining	5.0 ... <b>95.0</b> ... 110.0 °C	Temperature setting for forced draining activation.	HF
Base load exaggeration	0,0 ... <b>5,0</b> ... 60Kase	The current GEN setpoint is increased by the set value of the base load exaggeration.	HF
Switching output	Off, 5% ... <b>65%</b> ... 100%	<b>Off</b> : All controllers run at 100% power <b>5% ... 100%</b> : All controllers are limited in power to the set value until the last stage is switched on.	HF
Start protection	Off, 5,0 ... <b>30.0</b> ... 85.0 °C	Temperature setting for start-up protection.	HF
Switching difference	2.0 ... <b>5.0</b> ... 20 K	Switching difference setting for the energy generator.	HF
Minimum runtime	Off, 0,5 ... <b>2.0</b> ... 360 Min	Minimum runtime setting for the energy generator per start.	HF
Maximum runtime	<b>Off</b> , 0,5 ... 360 Min	Maximum runtime setting for the energy generator per start.	HF
Switch-off time	<b>Off</b> , 0,5 ... 360 Min	Break time setting for the energy generator between two starts.	HF
Exhaust gas control	<b>Off</b> , 50.0 ... 500.0 °C	Temperature setting for exhOfft gas control. If the set temperature is exceed, the energy generator is blocked dependent on the "Blocking time" parameter or the safety temperature limiter (SLT) is triggered.	HF
Blocking time	<b>Off</b> , 5 ... 60 Min, SLT	Setting of the blocking time by triggering exhOfft gas control or SLT function selection.	HF
Summer lock	<b>Off</b> , (winter block + 1 K) ... 30.0 °C	Temperature setting for the summer block. If the outside temperature exceeds the set summer block, the energy generator is blocked (HP-bivalence point).	HF

Menu / Parameter	Setting range	Description	Access
Expert / Energy generator 1 or 2 / <b>Basic settings</b>			
Winter lock	<b>Off</b> , -20.0 °C ... (Summer lock – 1 K)	Temperature setting for the winter block. If the outside temperature exceeds the set winter block, the energy generator is blocked (HP-bivalence point).	HF
Fault release	Off, <b>On</b>	Activation of fault release. If an outside sensor is faulty, an activated summer or winter block is cleared.	HF
Full load shutdown	Off, 0,5 ... 10 min.	Minimum load control (OpenTherm). Blocking of the GEN for the set time.	HF
Heating mode	Off, high priority medium priority low priority	Priority selection in cascade operation	HF
Hot water mode	Off, high priority medium priority low priority	Priority selection in cascade operation	HF
Cooling mode	Off, high priority medium priority low priority	Priority selection in cascade operation	HF
Mode	<b>normal operation</b> emergency mode	If there is more than one GEN, one GEN stage can be activated as an emergency boiler.	HF
Shutdown	<b>Minimum temperature,</b> Request	GEN Shutdown performance when Request is cancelled.	HF
Start detection	<b>Off</b> , 1...360 min.	If the GEN minimum temperature is not reached within this time, the "emergency mode boiler" is enabled. Error code 50-3	HF
Name	Alphanumeric, maximum of 15 characters, no special characters	Entry of the name for the energy generator.	HF

Menu / Parameter	Setting range	Description	Access
Expert / Energy generator 1 or 2 / <b>Modulation</b>			
Switch on mode	start output Setpoint	Function of the modulation	HF
Start time	Off, 10, <b>20</b> , ... 3600 sec.	Setting the start time of the modulation.	HF
Start output	1 ... <b>40</b> ... 100%	Setting the modulation start output.	HF
Minimum limitation	0 ... <b>10</b> ... 100 %	Minimum output	HF
Maximum limitation	0 ... <b>100%</b>	Maximum output	HF
Runtime	Off, 1 ... <b>12</b> ... 600	Adjustment of the modulation time of the actuator	HF
Regulation gain	1 ... <b>5,0</b> ... 50,0%/K	Setting the gain of the modulation PID controller.	HF
Regulation adjust time	1 ... <b>180</b> ... 600 sec.	Setting the adjustment time of the modulation PID controller.	HF
Regulation scan time	1 ... 20 ... 600 sec.	Setting the scan time of the modulation PID controller.	HF

Menu / Parameter	Setting range	Description	Access
Expert / Energy generator 1 or 2 / <b>Pump</b>			
Lead time	<b>Off</b> , 0,5 ... 360 min	Setting the lead time of the charge Pump.	HF
Overrun time	<b>Off</b> , 0,5 ... 360 min	Setting the after-running time of the charge Pump.	HF
Anti-lock system	Off, 5 ... <b>20</b> ... 300 Sec.	Setting the running time for the anti lock protection of the charge Pump.	HF
Start protection	<b>Off</b> , 5 ... 85°C	Start protection relief modulating boiler Pump	HF
Switch on mode	<b>Constant mode</b> , Temperatur spread, Setpoint	Selection of the operation mode for speed control of the charge Pump.	HF
Interrupting voltage	<b>Off</b> , 0,1 ... 10 V	Setting the interrupting voltage of the charging Pump.	HF
Start time	Off, 1 ... <b>10</b> ... 240 Sec.	Setting the start time of the charge Pump.	HF
Start output	0 ... <b>100 %</b>	Setting the starting output of the charge Pump.	HF
Output	1 ... <b>100 %</b>	Setting the charge Pump output.	HF
Minimum voltage	<b>0,0</b> ... 10 V	Setting the minimum voltage of the charge Pump.	HF
Minimum output	<b>0</b> ... 100 %	Setting the minimum charge Pump output.	HF
Maximum voltage	0,0 ... <b>10 V</b>	Setting the maximum voltage of the charge Pump.	HF

Menu / Parameter	Setting range	Description	Access
Expert / Energy generator 1 or2 / <b>Pump</b>			
Maximum output	0 ... <b>100 %</b>	Setting the maximum output of the charge Pump.	HF
Regulation gain	1,0 ... <b>2,0</b> ... 50 %/K	Setting the gain of the PID regulator for the charge Pump.	HF
Regulation adjust time	1 ... <b>270</b> ... 600 Sec.	Setting the adjustment time of the PID controller for the charge Pump.	HF
Regulation scan time	1 ... <b>20</b> ... 600 Sec.	Setting the scan time of the PID controller for the charge Pump.	HF
Heating spread	2,0 ... <b>15,0</b> ... 30,0K	Setting the temperature spread for heating circuit requirements	HF
Heating release	<b>Off</b> , On	Enabling the heating Pump for heating requirements	HF
Hot water release	<b>Off</b> , On	Enabling the heating Pump when hot water is required	HF

Menu / Parameter	Setting range	Description	Access
Expert / Energy generator 1 or2 / <b>Heating</b>			
Switch-on delay	<b>Off</b> , 0.5 ... 360 min	Setting of the switch-on and switch-off delay for the second stage of the energy generator.	HF
Switch-off delay			
Minimum temperature	5.0 ... <b>38.0 °C</b> ... Maximum temperature	Minimum temperature setting of the energy generator.	HF
Maximum temperature	Minimum temperature ... <b>80.0 °C</b> ... 95	Maximum temperature setting of the energy generator.	HF
Switching difference	-30.0 ... <b>-3.0 K</b> ... 30.0	Switching difference setting of the energy generator for a heating Request.	HF
Hysteresis	1.0 ... <b>6.0 K</b> ... 30.0	Energy generator hysteresis setting when a heating Request is received.	HF

Menu / Parameter	Setting range	Description	Access
Expert / Energy generator 1 / <b>Domestic hot water</b>			
Switch-on delay	<b>Off</b> , 0.5 ... 360 min	Setting of the switch-on and switch-off delay for the second stage of the energy generator.	HF
Switch-off delay			
Minimum temperature	5.0 ... <b>38.0 °C</b> ... Maximum temperature	Minimum temperature setting of the energy generator.	HF
Maximum temperature	Minimum temperature ... <b>80.0 °C</b> ... 95	Maximum temperature setting of the energy generator.	HF

Menu / Parameter	Setting range	Description	Access
Expert / Energy generator 1 / Domestic hot water			
Switching difference	-30.0 ... <b>-3.0 K</b> ... 30.0	Switching difference setting of the energy generator for a hot water Request.	HF
Hysteresis	1.0 ... <b>6.0 K</b> ... 30.0	Hysteresis setting of the energy generator when a heating Request is received.	HF
Blocking overrun time	<b>Off</b> , On	Activation of the overrun time time block. If the block is activated, the valves remain in the hot water position until the energy generator overrun time time has elapsed. This implies a forced shutdown of the energy generator before it can serve a heating Request.	HF

Menu / Parameter	Setting range	Description	Access
Expert / Energy generator 1 or2 / Cooling			
Switch-on delay	<b>Off</b> , 0,5 ... 360 min.	Setting the switch-on and switch-off delay for the second stage of the energy generator.	HF
Switch-off delay	<b>Off</b> , 0,5 ... 360 min.		
Minimum temperature	<b>5,0</b> .... Max. temperature	Setting the minimum temperature of the energy generator.	HF
Maximum temperature	Min. temperature ... <b>80,0 °C</b> .... 95 °C	Setting the maximum temperature of the energy generator.	HF
Switching difference	-30,0 ... <b>3,0 K</b> ... 30,0	Setting of the switching difference of the energy generator in case of a cooling Request.	HF
Hysteresis	-30,0 ... <b>-6,0 K</b> ... -1,0	Setting of the hysteresis of the energy generator in case of a cooling Request.	HF

Menu / Parameter	Setting range	Description	Access
Expert / Energy generator 1 or2 / Heat balance			
Volume flow	<b>Off</b> , 1 ... 300 L/min or L/pulse	Setting of the volume flow for heat consumption measurement or setting of the units for pulse input of a flowmeter.	HF
Medium density	0.8 ... <b>1.05</b> ... 1.2 kg/L	Density setting of the heat transfer medium for heat consumption measurement.	HF
Medium heat capacity	1.0 ... <b>3.6</b> ... 50 kJ/kg*K	Heat capacity setting of the heat transfer medium for heat consumption measurement.	HF
Output 1	<b>Off</b> , 1.0 ... 100.0 kW	thermal power (thermal output) setting of the energy generator stages.	HF
Output 2		The heat quantity is calculated from the heating output set here and the runtime.	
Reset	<b>Off</b> , set	Resetting of the meter for heat consumption measurement.	HF

Menu / Parameter	Setting range	Description	Access
Expert / Energy generator / <b>Reset</b>			
Reset	<b>Off</b> , set	Resetting of the parameters in the “Energy generator” menu to factory presets, dependent on access rights.	BE

## 8.10 Menu – Heating buffer (1) (2)

Menu / Parameter	Description	
Expert / Heating buffer / <b>Information</b>		
State	Display of the status	
	Absorption	Absorption function active
	Start protection	Charging Pump is blocked by the GEN minimum temperature
	Off	Charging switched off
	Blocking	Blocking active
	Discharge protection	Buffer charging blocked until GEN actual $\geq$ heating buffer target +5K
	On	Charging switched on
	Frost protection	Frost protection function active
	Manual mode	Manual mode active
	Maximum limitation	Overtemperature in the heating buffer
	Setpoint reduction	Setpoint reduction by differential control
Setpoint	Display of the current Setpoint for the heating buffer.	
current temperature (1)	Display of the current temperature BS1 (buffer top)	
current temperature (2)	Display of the current temperature BS2 (buffer bottom)	
Pump	Display of the status of the buffer load Pump or the buffer switching valve.	
Request contact	Status display of the external Request contact of the buffer storage (option).	
Hydraulic buffer discharge	Status display of the hydraulic buffer discharge.	
Request	Display of the current Setpoint temperature which is forwarded for supply of the heating buffer.	
current temperature	Display of the actual temperature of the energy generator.	

Menu / Parameter	Setting range	Description	Access
Expert / Heating buffer / <b>Basic settings</b>			
Switching difference	1.0 ... <b>5.0 K</b> ... 70.0	Switching difference setting for buffer charging. Start charging: If actual temperature < Setpoint - switching difference	HF
Minimum temperature	5 ... <b>20.0°C</b> ... 110.0	Minimum temperature setting for the heating buffer.	HF



Menu / Parameter	Setting range	Description	Access
Expert / Heating buffer / <b>Basic settings</b>			
Maximum temperature	5 ... <b>75.0°C</b> ... 110.0	Maximum temperature setting for the heating buffer.	HF
Increase of Request	-5.0 ... <b>10.0K</b> ... 80.0	Raising setting for forwarding the requirement to the energy source.	HF
Discharge protection	Off, <b>On</b>	Activation of the discharge protection function for the heating buffer.	HF
Forced draining	5.0 ... <b>95.0</b> ... 110.0 °C	Temperature setting for forced draining activation.	HF
Constant temperature	<b>Off</b> , 7.0 ... 110.0 °C	Heating buffer temperature setting with an activated external Request contact	HF
Absorption	<b>Off</b> , 10.0 ... 100.0 °C	Temperature setting for activation of the absorption function.	HF
Switch on difference	0 ... <b>10.0 K</b> ... 100.0	Switch on difference setting if the absorption function is activated.	HF
Switch-off difference	0 ... <b>5.0 K</b> ... 50.0	Switch-off difference with the absorption function activated.	HF
Start protection	<b>Off</b> , 5.0 ... 30.0 ... 85.0 °C	Temperature setting for start-up protection.	HF
Name	Alphanumeric, maximum of 15 characters, no special characters	Entry of the name for the heating buffer.	HF

Menu / Parameter	Setting range	Description	Access
Expert / Heating buffer / <b>Pump</b>			
Overrun time	Off, 0.5 ... 360 Min	Overrun time time setting of the charging Pump.	HF
Anti-lock system	Off, 5 ... 20 ... 300 sec	Runtime setting for the anti-lock protection of the charging Pump.	HF
Switch on mode	Constant operation, temperature spread, Setpoint	Operation mode selection for control of the charging Pump.	HF
Interruption voltage	Off, 0.1 ... 10 V	Cut-off voltage setting of the charging Pump.	HF
Start time	Off, 1 ... 10 ... 240 sec	Start time setting of the charging Pump.	HF
Start output	0 ... 100 %	Starting capacity setting of the charging Pump.	HF
Output	1 ... 100 %	Capacity setting of the charging Pump.	HF
Minimum voltage	0.0 ... 5.0 ... 10 V	Minimum voltage setting of the charging Pump.	HF
Minimum output	0 ... 50 ... 100 %	Minimum capacity setting of the charging Pump.	HF
Maximum voltage	0.0 ... 10 V	Maximum voltage setting of the charging Pump.	HF

Menu / Parameter	Setting range	Description	Access
Expert / Heating buffer / <b>Pump</b>			
Maximum output	0 ... 100 %	Maximum capacity setting of the charging Pump.	HF
Regulation gain	1.0 ... 2.0 ... 50 %/K	Gain setting of the PI controller for the charging Pump.	HF
Regulation adjust time	1 ... 270 ... 600 sec	Reset time setting of the PI controller for the charging Pump.	HF
Regulation scan time	1 ... 20 ... 600 sec	Sample time setting of the PI controller for the charging Pump.	HF
Temperature spread	2.0 ... 10.0 ... 20.0K	Temperature spread setting for the "Temperature spread" switch-on type.	HF

Menu / Parameter	Setting range	Description	Access
Expert / Heating buffer / <b>Reset</b>			
Reset	Off, set	Resetting of the parameters in the "Heating Buffer" menu to factory presets, dependent on access rights.	HF

## 8.11 Menu – Solar

Menu / Parameter	Description
... / Solar / Information	
State	Display of the current status
	Off
	On
	Emergency mode
	Blocking time
	Anti-lock system
	Start time
	Manual mode
	Frost protection (with recooling)
	Minimum runtime
	Overrun time
Valve 1	Status display for valve 1 with East-West circuit (option).
current temperatureVF1	Display of the current temperature FS1 (solar field 1).
Valve 2	Status display for valve 2 with East-West circuit (option).
current temperatureVF2	Display of the current temperature FS2 (solar field 2).
current temperatureRF	Display of the current temperature of the return flow sensor (option).
current temperaturePF	Display of the current temperature of the buffer storage.
Pump	Display of the status of the solar circuit Pump.
Valve	Status display of the solar charging valve (SLV).
current temperatureSLVF	Display of the current temperature of the solar charging valve sensor (SLVS).
Starts	Display of the number of Pump starts of the solar charging Pump.
Runtime	Display of the solar charging Pump runtime.
Thermal output	Display of the current Thermal output Solar in KW.
Heat quantity	Current heat quantity meter reading for solar in KWh

Menu / Parameter	Setting range	Description	Access
... / Solar / <b>Basic settings</b>			
Switch on difference	1.0 ... <b>10.0 K</b> ... 30.0	Switch on difference setting for the solar circuit Pump. Start charging: If actual temperature < Setpoint - switch on difference	HF
Switch-off difference	2.0 ... <b>5.0 K</b> ... 27.0	Switch-off difference setting for the solar circuit Pump.	HF
Minimum temperature	Off, 10.0 ... <b>20.0°C</b> ... 110.0	Minimum temperature setting for differential control release.	HF
Maximum temperature	Off, 20.0 ... <b>110.0°C</b> ... 210.0	Maximum temperature setting for forced switching on of the solar circuit Pump.	HF
Limit stop	Off, 20.0 ... <b>110.0°C</b> ... 250.0	Setting of the maximum collector flow for final switch-off.	HF
Storage maximum temperature	Off, 20.0 ... <b>75.0°C</b> ... 110.0	Maximum temperature setting for the solar storage.	HF
Operation mode	<b>Parallel</b> , Energy generator priority, Hot water priority, priority buffer	Selection of the operation mode for solar control.	HF
Time lock	<b>Off</b> , 0.5 ... 24 h	Time setting for the cycling interruption of the energy generator. The cycling interruption serves to prevent frequent switching between solar charging and energy generator charging.	HF
Parallel	<b>Off</b> , 1.0 ... 30 K	Temperature setting for the solar parallel switchover. The switchover takes place if the set temperature differential relative to the Setpoint is undershot.	HF
Changeover time	Off, 1.0 ... <b>30.0 min</b> ... 60.0 min	Checking interval setting for the solar charging switchover.	HF
Changeover temperature	Off, 20.0 ... <b>75.0 °C</b> ... 110.0	Temperature setting for the solar charging switchover.	HF
Frost protection	<b>Off</b> , -15.0 ...10.0 °C	Frost protection limit setting of the heat transfer medium of the solar thermal system. If the outside temperature falls below the frost protection limit set here, back heating of the collector is performed from the buffer storage.	HF
Recooling	<b>Off</b> , 5.0 ...50.0 K	Temperature differential setting for the recooling function. If the set temperature difference is undershot, the solar circuit Pump is switched off.	HF
Forced draining	<b>Off</b> , hot water, heating circuit, heating buffer, external	Selection of the type of forced draining for the solar storage.	HF
Name	Alphanumeric, maximum of 15 characters, no special characters	Entry of the name for the solar control unit.	HF

Menu / Parameter	Setting range	Description	Access
Expert / Solar / Pump			
Minimum runtime	Off, 0.5 ... 360 min	Minimum runtime setting of the solar circuit Pump.	HF
Break time	Off, 0.5 ...99 min	Break duration setting of the solar circuit Pump.	HF
Anti-lock system	Off, 5 ... <b>20</b> ... 300 sec	Runtime setting for the anti-lock protection of the solar circuit Pump.	HF
Switch on mode	<b>Constant operation</b> , temperature spread, Setpoint	Selection of the operation mode for the solar circuit Pump	HF
Interruption voltage	Off, 0.1 ... 10 V	Interruption voltage setting of the solar circuit Pump.	HF
Start time	Off, 1 ... <b>10</b> ... 240 sec	Start time setting of the solar circuit Pump.	HF
Start output	0 ... <b>100</b> %	Start capacity setting of the solar circuit Pump.	HF
Output	1 ... <b>100</b> %	Capacity setting of the solar circuit Pump.	HF
Minimum voltage	0.0 ... <b>5.0</b> ... 10 V	Minimum voltage setting of the solar circuit Pump.	HF
Minimum output	0 ... <b>50</b> ... 100 %	Minimum capacity setting of the solar circuit Pump.	HF
Maximum voltage	0.0 ... <b>10 V</b>	Maximum voltage setting of the solar circuit Pump.	HF
Maximum output	0 ... <b>100</b> %	Maximum capacity setting of the solar circuit Pump.	HF
Regulation gain	1.0 ... <b>2.0</b> ... 50 %/K	Gain setting of the PI controller for the solar circuit Pump.	HF
Regulation adjust time	1 ... <b>270</b> ... 600 sec	Reset time setting of the PI controller for the solar circuit Pump.	HF
Regulation scan time	1 ... <b>20</b> ... 600 sec	Sample time setting of the PI controller for the solar circuit Pump.	HF
Temperature spread	2.0 ... <b>10.0</b> ... 30.0K	Temperature spread setting for the "Temperature spread" switch-on type.	HF
Manual driving	Off, 0.5 ... 10.0 Min	Manual mode of the solar circuit Pump for filling or bleeding.	HF
Reset counter	Off, set	Resetting of the meter (Pump starts, Pump runtime).	BE

Menu / Parameter	Setting range	Description	Access
... / Solar / Heat balance			
Volume flow	Off, 0.5 ... 300 L/min or L/pulse	Setting of the volume flow for heat consumption measurement or setting of the units for pulse input of a flowmeter.	HF
Medium density	0.8 ... 1.05 ... 1.2 kg/L	Density setting of the heat transfer medium for heat consumption measurement.	HF
Medium heat capacity	1.0 ... 3.6 ... 50 kJ/kg*K	Heat capacity setting of the heat transfer medium for heat consumption measurement.	HF
Reset	Off, set	Resetting of the meter for heat consumption measurement.	HF

Menu / Parameter	Setting range	Description	Access
Expert / Solar / Reset			
Reset	Off, set	Resetting of the parameters in the "Solar" menu to factory presets, dependent on access rights	HF

## 8.12 Menu – Solid

Menu / Parameter	Description
Expert / Solid / Information	
State	Display of the current state
	Off
	On
	Emergency mode
	Blocking time
	Anti-lock system
	Start time
	Manual mode
	Minimum runtime
	Overrun time
Current temperature flow sensor	Display of the current temperature VF1 (solid fuel boiler sensor).
Current temperature return flow sensor	Display of the current temperature of the return flow sensor (option).
Current temperature buffer sensor	Display of the current temperature of the buffer tank (bottom).
Pump	Display of the current state of the solid charge Pump.
Starts	Display of the Pump starts of the solids charge Pump.
Runtime	Display of the running time of the solids charge Pump.
Forced draining	Status of an activated forced drainage.
(thermal power) Thermal output	Display of the current thermal output solid fuel in KW
Heat quantity	Current reading of the heat quantity meter for solid fuel in KWh.

Menu / Parameter	Setting range	Description	Access
Expert / Solid / <b>Basic settings</b>			
Switch on difference	1,0 ... <b>10,0 K</b> ... 30,0	Setting of the switch on difference for the solids charge Pump. Start charging: When actual temperature < Setpoint - power on difference	HF
Switch-off difference	2,0 ... <b>5,0 K</b> ... 27,0	Setting of the power-off difference of the solids charge Pump.	HF
Minimum temperature	Off, 10,0 ... <b>20,0°C</b> ... 110,0	Setting of the minimum temperature for enabling differential control.	HF
Maximum temperature	Off, 20,0 ... <b>110,0°C</b> ... 210,0	Setting of the maximum temperature for forced activation of the solids charge Pump.	HF
Storage maximum temperature	20,0 ... <b>75,0°C</b> ... 110,0	Setting of the maximum temperature for the solids buffer storage tank.	HF
Operation mode	<b>Parallel</b> , priority energy generator, priority hot water, priority buffer	Selection of the operation mode for solids control.	HF
Time lock	<b>Off</b> , 0,5 ... 24 h	Setting of the time for the time lock of the energy generator. The time lock is used to avoid a frequent timing between solid charge and charge by the energy generator. (not in parallel operation mode)	HF
Parallel	<b>Off</b> , 1,0 ... 30 K	Setting temperature for the solar parallel switchover. If the temperature falls below the set difference to the Setpoint, the switchover takes place.	HF
Forced draining	<b>Off</b> , Hot water, heating circuit, heating buffer, external	Selection of the type of forced drainage for the solids storage tank.	HF
Name	Alphanumeric, max. 15 characters, no special characters	Enter the name for the solids control.	HF

Menu / Parameter	Setting range	Description	Access
Expert / Solid / <b>Pump</b>			
Overrun time	<b>Off</b> , 0,5 ... 360 Min	Setting of the solid charge Pump run-after time.	HF
Anti-lock system	Off, 5 ... <b>20</b> ... 300 Sek	Setting of the running time for the anti-lock system of the solid charge Pump.	HF
Switch on mode	<b>Constant mode</b> , Temperature spread, Setpoint	Selecting the operation mode for the solid charge Pump	HF
Interrupting voltage	<b>Off</b> , 0,1 ... 10 V	Setting the interruption voltage of the solid charge Pump	HF
Start time	Off, 1 ... <b>10</b> ... 240 Sek	Setting the start time of the solid charge Pump.	HF
Start output	0 ... <b>100 %</b>	Setting the starting power of the solid charge Pump.	HF
Output	1 ... <b>100 %</b>	Setting the output of the solid charge Pump.	HF



Menu / Parameter	Setting range	Description	Access
Expert / Solid / <b>Pump</b>			
Minimum voltage	0,0 ... <b>5,0</b> ... 10 V	Setting the minimum voltage of the solid charge Pump.	HF
Minimum output	0 ... <b>50</b> ... 100 %	Setting the minimum output of the solid charge Pump.	HF
Maximum voltage	0,0 ... <b>10 V</b>	Setting the maximum voltage of the solid charge Pump.	HF
Maximum output	0 ... <b>100</b> %	Setting of the maximum output of the solid charge Pump.	HF
Regulation gain	1,0 ... <b>2,0</b> ... 50 %/K	Setting the gain of the PI controller for the solid charge Pump.	HF
Regulation adjust time	1 ... <b>270</b> ... 600 Sek	Setting the adjust of the PI controller for the solid charge Pump.	HF
Regulation scan time	1 ... <b>20</b> ... 600 Sek	Setting the scan time of the PI controller for the solid charge Pump.	HF
Temperature spread	2,0 ... <b>10,0</b> ... 30,0K	Setting the temperature spread for the "Temperature spread" switch-on mode.	HF
Manual driving	<b>Off</b> , 0,5 ... 10,0 Min	Manual mode of the solid charge Pump	HF
Reset counter	<b>Off</b> , Set	Reset the counters (Pump starts, Pump running time).	BE

Menu / Parameter	Setting range	Description	Access
Expert / Solid fuel / <b>Heat balance</b>			
Volume flow	<b>Off</b> , 0,5 ... 300 L/Min or L/pulse	Setting the volume flow for heat balancing or setting the unit for the pulse input of a flow meter.	HF
Medium density	0,8 ... <b>1,05</b> ... 1,2 kg/L	Setting the density of the heat transfer medium for heat balancing.	HF
Medium heat capacity	1,0 ... <b>3,6</b> ... 50 kJ/kg*K	Setting the heat capacity of the heat transfer medium for heat balancing.	HF
Reset	Off, Set	Resetting the meter for heat balancing.	HF

Menu / Parameter	Setting range	Description	Access
Expert / Solid fuel / <b>Reset</b>			
Reset	Off, Set	Resetting the parameters in the "Solid" menu to factory settings according to the access authorization	HF

## 8.13 Menu – Return flow

Menu / Parameter	Description
Expert / Return flow / <b>Information</b>	
State	Display of the current state
Setpoint	Display of the return Setpoint.
Current temperature	Display of the current return temperature (only mixed heating circuit).
Pump	State of the return pump On/Off
Mixing valve	Calculated position of the actuator

Menu / Parameter	Setting range	Description	Access
Expert / Return flow / <b>Basic settings</b>			
Setpoint	Off, 10 ... <b>20°C</b> ... 95°C	Setpoint return flow	HF
Switching difference	1, <b>2K</b> , ... 20K	Switching difference Pump	HF

Menu / Parameter	Setting range	Description	Access
Expert / Return flow / <b>Pump</b>			
Anti-lock system	<b>Off</b> , 5 ... 300 sec	Setting the runtime for the anti-lock protection of the return Pump.	HF
Switch on mode	<b>Constant mode</b> , Temperature spread, Setpoint	Selection of the operation mode for the speed control of the return Pump.	HF
Interrupting voltage	<b>Off</b> , 0,1 ... 10 V	Setting the switch-off voltage of the return Pump.	HF
Start time	Off, 1 ... <b>10</b> ... 240 sec	Setting the start time of the return Pump.	HF
Start output	0 ... <b>100 %</b>	Setting the starting output of the return Pump.	HF
Output	1 ... <b>100 %</b>	Setting the output of the return Pump	HF
Minimum voltage	0,0 ... <b>5,0</b> ... 10 V	(for constant operation switch-on mode)	HF
Minimum output	0 ... <b>50</b> ... 100 %	Setting the minimum voltage of the return Pump.	HF
Maximum voltage	0,0 ... <b>10 V</b>	Setting the minimum output of the return Pump.	HF
Maximum output	0 ... <b>100 %</b>	Setting the maximum voltage of the return Pump.	HF
Regulation gain	1,0 ... <b>2,0</b> ... 50 %/K	Setting the gain of the PID controller for the return Pump.	HF

Menu / Parameter	Setting range	Description	Access
Expert / Return flow / <b>Pump</b>			
Regulation adjust time	1 ... <b>270</b> ... 600 sec	Setting the adjustment time of the PID controller for the return Pump.	HF
Regulation scan time	1 ... <b>20</b> ... 600 sec	Setting the scan time of the PID controller for the return Pump.	HF
Temperature spread	2,0 ... <b>10,0</b> ... 20,0K	Setting the temperature spread for the "temperature spread" switch-on mode.	HF

Menu / Parameter	Setting range	Description	Access
Expert / Return flow / <b>Mixing valve</b>			
Regulation gain	1,0 ... <b>2,0</b> ... 50 %/K	Setting the gain of the PID controller for the mixing valve.	HF
Regulation adjust time	1 ... <b>270</b> ... 600 sec	Setting the adjustment time of the PID controller for the mixing valve.	HF
Regulation scan time	1 ... <b>20</b> ... 600 sec	Setting the scan time of the PID controller for the mixing valve.	HF
Runtime	1 ... <b>120</b> ... 600 sec	Running time of the valve actuator	HF
Stop position deactivation	<b>Off, On</b>	Valve end position control	HF
Anti-lock system	Off, 1 ... <b>20</b> ... 300 sec	Setting the runtime for the anti-blocking protection of the mixing valve.	HF

Menu / Parameter	Setting range	Description	Access
Expert / Return flow / <b>Reset</b>			
Reset	Off, set	Resetting the parameters in the " Return flow " menu to factory setting according to the access authorisation.	HF

## 8.14 Menu – Extras

Menu / Parameter	Description
Expert / Extras / Information	
State	Display of the status
	INFO-1
	INFO-2
	INFO-3
	State fault message input 1
	State fault message input 2
	State fault message input 3
	State fault message output
	Summer

Menu / Parameter	Setting range	Description	Access
Expert / Extras / Fault message input 1 / 2 / 3			
Delay	Off, 0,5 ... 360 min.	Fault message is displayed delayed by the value entered here and, if necessary, stored in the fault stack.	HF
Error Stack	Off, On	Storage of the fault message in the error stack	HF
Name	Alphanumeric, max. 15 characters, no special characters	Enter the name of the fault signal input.	BE

Menu / Parameter	Setting range	Description	Access
Expert / Extras / Fault message output			
Delay	Off, 0,5 ... 360 min.	Fault message is displayed delayed by the value entered here and, if necessary, stored in the fault stack.	HF
Mode	1, 2, 3	Switching condition due to error significance 1 = Locking 2 = Locking, Blocking, System failures 3 = Locking, Blocking, Warnings, System failures	HF

Menu / Parameter	Setting range	Description	Access
... / Extras / <b>INFO 1, 2, 3</b>			
Name	Alphanumeric, max. 15 characters, no special characters	Enter the name of the fault signal input.	BE

## 8.15 Menu – Configuration

Information on system configuration and the values applied to the inputs can be checked in the "Configuration" menu.

Additionally, you can make further adjustments to the system, which cannot be made via the setup wizard.

### 8.15.1 Menu – Information

The implemented system configuration and the values applied to the inputs can be checked in the "Information" submenu.

Menu / Parameter	Description
Expert / Configuration / <b>Information</b>	
Measurements	Display of the input states of inputs E1 ... E17 in the <i>heatcon!</i> system. If a function is assigned to an input, the brief description of the function is displayed instead of the input number.
Pin assignment	Display of the input and output assignments in the <i>heatcon!</i> system. If a function is assigned to an input/output, the brief description of the function is displayed as well as the input/output number.
Room mapping	Display of the assignment of the rooms to the heating circuits in the <i>heatcon!</i> system. If a name is assigned to a heating circuit/room, the name is also displayed.

### 8.15.2 Menu – function

Adjustments can be made to the controller functions and the input and output assignments in the "*Function*" submenu as a supplement the setup wizard.

Menu / Parameter	Setting range	Description	I/O type/Fixed I/O assignment
Expert / Configuration / Function / <b>Energy generator 1 or2</b>			
Function	Selection of the type of energy generator. The assignment of the inputs and outputs is dependent on the selected energy generator type.		
	Off	No energy generator available.	–
	Single-stage burner	Single stage energy generator, actuation On/Off.	A1:BR1; E5:WF
	Two-stage burner	Two-stage energy generator, actuation On/Off	A1:BR1; A2:BR2AUF; E5:WF

Menu / Parameter	Setting range	Description	I/O type/Fixed I/O assignment
Expert / Configuration / Function / <b>Energy generator 1 or2</b>			
	Power Signal on/off (Relay)	Modulating energy generator, switch on via relay BR1, modulation via digital On/Off signal	A1:BR1; A2:BR2AUF; A3:BR2ZU; E5:WF
	Burner control system (OT/Bus)	Energy generator actuation via data bus protocol	EEZ-BUS
	Temperature signal 0-10V	Switch on via relay, temperature Setpoint via analogue 0 ... 10V signal	A14:0-10V;
	Release contact	Release of an external energy generator via switch contact	A1:BR1
	Power signal 0-10V	Modulating energy generator, switch on via relay BR1, modulation via analogue 0 ... 10V signal	A1:BR1; A14:0-10V; E5:WF
Pump relays	Off, free output	Actuation of the energy generator Pump (e.g. KKP, CP)	ARS, ARSP
Pump 10V	Off, free output	Energy generator Pump speed control - speed actuation signal.	A10V
Flow sensor	Off, E4:EFI ... E15:EFI	Energy generator Pump speed control – flow temperature (only if Pump 10V is active).	EFI (KTY2K/PT1000)
Return flow sensor	Off, E4:EFI ... E15:EFI	Energy generator Pump speed control - return flow sensor (only if Pump 10V is active).	EFI (KTY2K/PT1000)
Boiler sensor 2	Off, E4:EFI ... E15:EFI	Activation of the boiler sensor 2nd	EFI (KTY2K/PT1000)
Boiler return flow sensor	Off, E4:EFI ... E15:EFI	Energy generator modulation 0-10V, operation mode temperature spreading	EFI (KTY2K/PT1000)
Exhaust gas sensor	Off, E4:EFI ... E15:EFI	Flue gas temperature measurement via PT1000 sensor (factory setting E9)	EFI (PT1000)
BLZ 1	Off, Free input	Determination of the energy generator runtime via feedback signal - stage 1	EI (Digital 0/1), EO
BLZ 2	Off, Free input	Determination of the energy generator runtime via feedback signal - stage 2	EI (Digital 0/1), EO
Diverter valve hot water (UWW)	Off, free output	Actuation of the hot water diverter valve.	ARS, ARSP
diverter valve cooling	Off, free Output	Control of a diverter valve cooling active	ARS, ARSP

Menu / Parameter	Setting range	Description	I/O type/Fixed I/O assignment
Expert / Configuration / Function / <b>Energy generator 1 or2</b>			
(parallel heating system approval) Parallel heat generator release	Off, free Output	Control of an output parallel to the GEN	ARS, ARSP
Primary Pump	Off, free Output	The primary Pump is activated when the heating circuit is Requested	ARS, ARSP
Forced draining	Off, free Output	Control of e.g. a Pump for forced discharge	ARS, ARSP
Blocking contact	EI:E1 ... E3, EO:E16,17	Input for an external block of the energy generator	EI (Digital 0/1), EO
Heat quantity (HTM)	Configuration of the heat meter function.		
	Off	No heat meter activated	
	Volume flow constant	Heat quantity via runtime and medium definition.	
	Flow rate measurement	Heat quantity via flow/return temperature and flow sensor (e.g. vortex). <b>NOTE:</b> Hardware configuration required	
	Pulse measurement	Heat quantity via flow/return temperature and pulse input. <b>NOTE:</b> Hardware configuration required	
	Runtime	Heat quantity via runtime and fixed coefficient of performance (e.g. multi-stage GEN)	
Flow sensor (HTM)	Off, E4:EFI ... E15:EFI	Flow sensor assignment for heat meter.	EFI (KTY2K/PT1000)
Return flow sensor (HTM)	Off, E4:EFI ... E15:EFI	Return flow sensor assignment for heat meter.	EFI (KTY2K/PT1000)
Volume flow sensor (HTM)	Off, E4:EFI ... E15:EFI	Flowmeter assignment for heat meter. <b>NOTE:</b> Hardware configuration required	EFI10V
Pulse input (HTM)	Off, E1:EI ... E3:EI, E4:EFI ... E15:EFI	Pulse input assignment for heat meter. <b>NOTE:</b> Hardware configuration required.	EI, EFI



Menu / Parameter	Setting range	Description	I/O type/Fixed I/O assignment
Expert / Configuration / Function / <b>Return flow</b>			
Return flow sensor	Off, E4:EFI ... E15:EFI	Return flow sensor input assignment.	EFI (KTY2K/PT1000)
Pump	Off, Free output	Control of the return Pump	ARS, ARSP
Pump 10V	Off, Free output	Speed control return Pump - control signal speed.	A10V
Flow sensor	Off, E4:EFI ... E15:EFI	Speed control of feed Pump - flow temperature (only if Pump 10V active).	EFI (KTY2K/PT1000)
Return flow sensor	Off, E4:EFI ... E15:EFI	Speed control of feed Pump - return flow sensor (only if Pump 10V active).	EFI (KTY2K/PT1000)
Mixing valve	Off, Free mixing valve	Mixing circuit as return bypass valve	ARS

Menu / Parameter	Setting range	Description	I/O type/Fixed I/O assignment
Expert / Configuration / Function / <b>Commen flow</b>			
Common flow sensor	Off, E4:EFI ... E15:EFI	Input assignment for common flow sensor.	EFI (KTY2K/PT1000)

Menu / Parameter	Setting range	Description	I/O type/Fixed I/O assignment
Expert / Configuration / Function / <b>Feed pump</b>			
Pump relais	Off, free output	Actuation of the feed Pump	ARS, ARSP
Pump 10V	Off, free output	Feed pump speed control - speed actuation signal.	A10V
Flow sensor	Off, E4:EFI ... E15:EFI	Feed pump speed control – flow temperature (only if Pump 10V is active).	EFI (KTY2K/PT1000)
Return flow sensor	Off, E4:EFI ... E15:EFI	Feed pump speed control - return flow sensor (only if Pump 10V is active).	EFI (KTY2K/PT1000)
Heat quantity (HTM)	Configuration of the heat meter function.		
	Off	No heat meter activated	
	Volume flow constant	Heat quantity via runtime and medium definition.	

Menu / Parameter	Setting range	Description	I/O type/Fixed I/O assignment
Expert / Configuration / Function / <b>Feed pump</b>			
	Flow rate measurement	Heat quantity via flow/return temperature and flow sensor (e.g. vortex). <b>NOTE:</b> Hardware configuration required	
	Pulse measurement	Heat quantity via flow/return temperature and pulse input. <b>NOTE:</b> Hardware configuration required	
Flow sensor (HTM)	Off, E4:EFI ... E15:EFI	Flow sensor assignment for heat meter.	EFI (KTY2K/PT1000)
Return flow sensor (HTM)	Off, E4:EFI ... E15:EFI	Return flow sensor assignment for heat meter.	EFI (KTY2K/PT1000)
Volume flow sensor (HTM)	Off, E4:EFI ... E15:EFI	Flowmeter assignment for heat meter. <b>NOTE:</b> Hardware configuration required	EFI10V
Pulse input (HTM)	Off, E1:EI ... E3:EI, E4:EFI ... E15:EFI	Pulse input assignment for heat meter. <b>NOTE:</b> Hardware configuration required.	EI, EFI

Menu / Parameter	Setting range	Description	I/O type/Fixed I/O assignment
Expert / Configuration / Function / <b>Heating buffer</b>			
Function	Selection of the heating buffer function.		
	Off	No heating buffer available.	
	Charge control	Heating buffer with charging control	
	Discharge control 1	Heating buffer with discharge control type 1.	
	Discharge control 2	Heating buffer with discharge control type 2.	
Supply	Supply selection for the heating buffer.	Supply	
	Off		
	Energy generator		
Heating buffer sensor 1	Off, E4:EFI ... E15:EFI	Heating buffer sensor 1	EFI (KTY2K/PT1000)

Menu / Parameter	Setting range	Description	I/O type/Fixed I/O assignment
Expert / Configuration / Function / <b>Heating buffer</b>			
Heating buffer sensor 2	Off, E4:EFI ... E15:EFI	Heating buffer sensor 2	EFI (KTY2K/PT1000)
Pump relais	Off, free output	Pump relais	ARS, ARSP
Pump 10V	Off, free output	Pump 10V	A10V
Flow sensor	Off, E4:EFI ... E15:EFI	Flow sensor	EFI (KTY2K/PT1000)
Return flow sensor	Off, E4:EFI ... E15:EFI	Return flow sensor	EFI (KTY2K/PT1000)
Hydraulic buffer discharge (HPE)	Off, free output	Hydraulic buffer discharge (HPE)	ARS, ARSP
Request contact	Off, Free input	Request contact	EI (Digital 0/1), EO
Setpoint connection	Off, E13:EFI ... E15:EFI	Setpoint connection	EFI (voltage in Setpoint temperature)

Menu / Parameter	Setting range	Description	I/O type/Fixed I/O assignment
Expert / Configuration / Function / <b>Domestic hot water</b>			
Function	Selection of the heating buffer function.		
	Off	No hot water storage available.	
	Storage pump	DHW charging via storage charging Pump TCP.	
	DHW circulation pump	Actuation of the circulation pump.	
	Burner control system (OT/Bus)	DHW charging via control system.	
	Heating usage	DHW charging via electrical Heating usage.	
Supply	Supply selection for the DHW storage.		
	Off	No active supply by the energy generator.	

Menu / Parameter	Setting range	Description	I/O type/Fixed I/O assignment
Expert / Configuration / Function / Domestic hot water			
	Energy generator	Active supply by the energy generator (Setpoint transfer)	
	Heating buffer	Active supply by the heating buffer (Setpoint transfer)	
DHW storage sensor 1	Off, E4:EFI ... E15:EFI	Assignment DHW storage sensor 1 (top)	EFI (KTY2K/PT1000)
DHW storage sensor 2	Off, E4:EFI ... E15:EFI	Assignment DHW storage sensor 2 (bottom)	EFI (KTY2K/PT1000)
Pump 10V	Off, free output	Speed control of the DHW storage charging Pump TCP – speed actuation signal.	A10V
Flow sensor	Off, E4:EFI ... E15:EFI	Speed control of the DHW storage charging Pump – flow temperature (only if Pump 10V is active).	EFI (KTY2K/PT1000)
Return flow sensor	Off, E4:EFI ... E15:EFI	Speed control of the DHW storage charging Pump – return flow sensor (only if Pump 10V is active).	EFI (KTY2K/PT1000)
Heating usage	Off, free output	Output assignment for a Heating usage.	ARS, ARSP
Flow sensor	Off, E4:EFI ... E15:EFI	Temperature sensor assignment for storage charging via Heating usage.	EFI (KTY2K/PT1000)
DHW circulation pump	Off, free output	Output assignment for DHW circulation pump.	ARS, ARSP
current temperature1	Off, E4:EFI ... E15:EFI	Differential sensor 1 for DHW circulation pump circuit (option)	EFI (KTY2K/PT1000)
current temperature2	Off, E4:EFI ... E15:EFI	Differential sensor 2 for DHW circulation pump circuit (option)	EFI (KTY2K/PT1000)
Setpoint connection	Off, E13:EFI ... E15:EFI	External Setpoint connection via 0-10V	EFI (voltage in Setpoint temperature)
Heat quantity (HTM)	Configuration of the heat meter function.		
	Off	No heat meter activated	
	Volume flow constant	Heat quantity via runtime and medium definition.	
	Flow rate measurement	Heat quantity via flow/return temperature and flow sensor (e.g. vortex).	

Menu / Parameter	Setting range	Description	I/O type/Fixed I/O assignment
Expert / Configuration / Function / <b>Domestic hot water</b>			
		<b>NOTE:</b> Hardware configuration required	
	Pulse measurement	Heat quantity via flow/return temperature and pulse input. <b>NOTE:</b> Hardware configuration required	
Flow sensor (HTM)	Off, E4:EFI ... E15:EFI	Flow sensor assignment for heat meter.	EFI (KTY2K/PT1000)
Return flow sensor (HTM)	Off, E4:EFI ... E15:EFI	Return flow sensor assignment for heat meter.	EFI (KTY2K/PT1000)
Volume flow sensor (HTM)	Off, E4:EFI ... E15:EFI	Flowmeter assignment for heat meter. <b>NOTE:</b> Hardware configuration required	EFI10V
Pulse input (HTM)	Off, E1:EI ... E3:EI, E4:EFI ... E15:EFI	Pulse input assignment for heat meter. <b>NOTE:</b> Hardware configuration required.	EI, EFI

Menu / Parameter	Setting range	Description	I/O type/Fixed I/O assignment
Expert / Configuration / Function / <b>Heating circuit 1 ... n</b>			
Function	Selection of the heating circuit type.		
	Off	No heating circuit 1 ... n available.	
	Direct circuit	Heating circuit with umixed circuit Pump	
	Mixer circuit	Heating circuit with mixer.	
Supply heating	Supply selection for the heating buffer.		
	Off	No active supply by the energy generator.	
	Energy generator	Active supply by the energy generator (Setpoint transfer)	
	Heating buffer	Active supply by the heating buffer (Setpoint transfer)	
Supply cooling	Off	No active supply by energy generators.	
	Energy generator	Passive supply by energy generator (transfer of Setpoint, selection only possible if a UKA is activated in the energy generator)	
	Diverter valve cooling	Switchover of the cooling diverter valve when cooling is required.	

Menu / Parameter	Setting range	Description	I/O type/Fixed I/O assignment
Expert / Configuration / Function / <b>Heating circuit 1 ... n</b>			
Pump 10V	Off, free output	Heating circuit Pump speed control - speed actuation signal.	A10V
Flow sensor	Off, E4:EFI ... E15:EFI	Heating circuit Pump speed control – flow temperature (only if Pump 10V is active).	EFI (KTY2K/PT1000)
Return flow sensor	Off, E4:EFI ... E15:EFI	Heating circuit Pump speed control - return flow sensor (only if Pump 10V is active).	EFI (KTY2K/PT1000)
Return flow limit	Off, E4:EFI ... E15:EFI	Sensor input assignment for indirect return temperature limiting of the heating circuit.	EFI (KTY2K/PT1000)
Heat quantity (HTM)	Configuration of the heat meter function.		EFI (voltage in Setpoint)
	Off	No heat meter activated	
	Volume flow constant	Heat quantity via runtime and medium definition.	
	Flow rate measurement	Heat quantity via flow/return temperature and flow sensor (e.g. vortex). <b>NOTE:</b> Hardware configuration required	
	Pulse measurement	Heat quantity via flow/return temperature and pulse input. <b>NOTE:</b> Hardware configuration required	
Flow sensor (HTM)	Off, E4:EFI ... E15:EFI	Flow sensor assignment for heat meter.	
Return flow sensor (HTM)	Off, E4:EFI ... E15:EFI	Return flow sensor assignment for heat meter.	EFI (KTY2K/PT1000)
Volume flow sensor (HTM)	Off, E4:EFI ... E15:EFI	Flowmeter assignment for heat meter. <b>NOTE:</b> Hardware configuration required	EFI (KTY2K/PT1000)
Pulse input (HTM)	Off, E1:EI ... E3:EI, E4:EFI ... E15:EFI	Pulse input assignment for heat meter. <b>NOTE:</b> Hardware configuration required.	EFI10V

Menu / Parameter	Setting range	Description	I/O type/Fixed I/O assignment
Expert / Configuration / Function / <b>Room group 1 ... n</b>			
Supply heating	off	No active supply of the room group	

Menu / Parameter	Setting range	Description	I/O type/Fixed I/O assignment
Expert / Configuration / Function / <b>Room group 1 ... n</b>			
	Heating circuit	Active supply by heating circuit 1 ... n (Setpoint transfer)	
	Heating buffer	Active supply by the heating buffer (Setpoint transfer)	
	Energy generator	Active supply by the energy generator (Setpoint transfer)	
Cooling	off	No active supply of the room group	
	Heating circuit 1 ... n	Active supply by heating circuit 1 ... n (forwarding) set point value	
	Energy generator	Active supply by energy generator (forwarding of Setpoint, selection only possible if a UKA is activated in the energy generator)	
Sense wire	Off, E4:EFI ... E15:EFI	Assignment of the wired room sensor <i>heatcon! sense wire</i> .	EFI (KTY2K/PT1000)
Room sensor	Z-Wave module ID (Display only)	In conjunction with the heatapp! single room control, the Z-Wave module ID is automatically entered when a wireless component is registered.	
Valve 1	Z-Wave module ID (Display only)	In conjunction with the heatapp! single room control, the Z-Wave module ID is automatically entered when a wireless component is registered.	
Valve 2			
Valve 3			
Valve 4			

Menu / Parameter	Setting range	Description	I/O type/Fixed I/O assignment
...Expert / Configuration / function / <b>Difference 1 ... 3</b>			
Function	Selection of the type of differential temperature control.		
	Off	No differential temperature control is active.	
	Solar	Differential temperature control for integration of a solar thermal system.	
	Solid fuel	Differential temperature control for integration of a solid fuel boiler.	
	Difference	Simple differential control	
Flow sensor	Off, E4:EFI ... E15:EFI	Differential controller 1 - hotter temperature <b>NOTE:</b> For PT1000, hardware configuration may be required.	EFI (KTY2K/PT1000)

Menu / Parameter	Setting range	Description	I/O type/Fixed I/O assignment
...Expert / Configuration / function / <b>Difference 1 ... 3</b>			
Valve 1	OFF, free output	Assignment of the first valve with East-West circuit of a solar thermal system.	ARS, ARSP
Flow sensor 2	Off, E4:EFI ... E15:EFI	Collector sensor of a second solar field with an East-West circuit (only if valve 1 is configured). <b>NOTE:</b> For PT1000, hardware configuration may be required.	EFI (KTY2K/PT1000)
Valve 2	OFF, free output	Assignment of the second valve with an East-West circuit of a solar thermal system (only if flow sensor 2 is assigned).	ARS, ARSP
Return flow sensor	Off, E4:EFI ... E15:EFI	Assignment of an alternative sensor for the switching difference monitoring of the Pump.	EFI (KTY2K/PT1000)
DHW storage sensor	Off, E4:EFI ... E15:EFI	Differential controller 2 - colder temperature. <b>NOTE:</b> For PT1000, hardware configuration may be required.	EFI (KTY2K/PT1000)
Pump relais	Off, free output	Actuation of the differential temperature Pump.	ARS, ARSP
Pump 10V	Off, free output	Speed control of the differential temperature Pump – speed actuation signal.	A10V
Flow sensor	Off, E4:EFI ... E15:EFI	Speed control of the differential temperature Pump – flow temperature (only if Pump 10V is active).	EFI (KTY2K/PT1000)
Return flow sensor	Off, E4:EFI ... E15:EFI	Speed control of the differential temperature Pump – return flow sensor (only if Pump 10V is active).	EFI (KTY2K/PT1000)
Diverter valve	Off, free output	Assignment of the diverter valve for charging two storages (heating buffer and DHW storage). <b>NOTE:</b> Only with solar differential control.	ARS, ARSP
Diverter valve sensor	Off, E4:EFI ... E15:EFI	Sensor for switching the diverter valve <b>NOTE:</b> Only with solar differential control. For PT1000, hardware configuration may be required.	EFI (KTY2K/PT1000)
Forced draining	Off, free output	Assignment of an output for forced draining. The output is switched, if the set collector maximum temperature is exceeded.	ARS, ARSP
Heat quantity (HTM)	Configuration of the heat meter function.	Configuration of the heat meter function.	
	Off	No heat meter activated	
	Volume flow constant	Heat quantity via runtime and medium definition.	
	Flow rate measurement	Heat quantity via flow/return temperature and flow sensor (e.g. vortex). <b>NOTE:</b> Hardware configuration required	
	Pulse measurement	Heat quantity via flow/return temperature and pulse input.	



Menu / Parameter	Setting range	Description	I/O type/Fixed I/O assignment
...Expert / Configuration / function / <b>Difference 1 ... 3</b>			
		<b>NOTE:</b> Hardware configuration required	
Flow sensor (HTM)	Off, E4:EFI ... E15:EFI	Flow sensor assignment for heat meter. EFI (KTY2K/PT1000)	
Return flow sensor (HTM)	Off, E4:EFI ... E15:EFI	Return flow sensor assignment for heat meter.	EFI (KTY2K/PT1000)
Volume flow sensor (HTM)	Off, E4:EFI ... E15:EFI	Flowmeter assignment for heat meter. <b>NOTE:</b> Hardware configuration required	EFI10V
Pulse input (HTM)	Off, E1:EI ... E3:EI, E4:EFI ... E15:EFI	Pulse input assignment for heat meter. <b>NOTE:</b> Hardware configuration required.	EI, EFI

Menu / Parameter	Setting range	Description	I/O type/Fixed I/O assignment
Expert / Configuration / Function / <b>Thermostat</b>			
output	Off, free output	Output assignment for the thermostat function.	ARS, ARSP
Sensor	Off, E4:EFI ... E15:EFI	Sensor for the thermostat function. <b>NOTE:</b> For PT1000, hardware configuration may be required.	EFI (KTY2K/PT1000)

Menu / Parameter	Setting range	Description	I/O type/Fixed I/O assignment
...Expert / Configuration / Function / <b>diverter valve cooling</b>			
Diverter valve colling	Off, free output	Control of a changeover valve Cooling Passive (UKP)	ARS, ARSP

Menu / Parameter	Setting range	Description	I/O type/Fixed I/O assignment
...Expert / Configuration / Function / Extras			
Outside sensor 2	Off, E4:EFI ... E15:EFI	Assignment of a second outside sensor.	EFI (KTY2K/PT1000)
Info 1	Off, E1:EI ... E17:EO	Only an information value, no function.	
Info 2			
Info 3			
Fault message input 1	Off, E1:EI ... E3:EI, E4: EFI ... E15: EFI E16:EO, E17:EO	Input for reporting an external fault.	EI (Digital 0/1), EO EFI (Digital on/off
Fault message input 2	Off, E1:EI ... E3:EI, E4: EFI ... E15: EFI E16:EO, E17:EO	Input for reporting an external fault.	EI (Digital 0/1), EO EFI (Digital on/off
Fault message input 3	Off, E1:EI ... E3:EI, E4: EFI ... E15: EFI E16:EO, E17:EO	Input for reporting an external fault.	EI (Digital 0/1), EO EFI (Digital on/off
Fault message output	Off, free output	Output for activation of a signal encoder.	
Summer	Off, free output	The output becomes active if all rooms/room groups are in summer shutdown.	
Switching contact	Off, E1:EI ... E17:EO	Input for using a Request contact or modem contact to a room group, heating zone and hot water	EI (Digital 0/1), EO

### 8.15.3 Menu – Hardware

Hardware settings can be made in the “Function” submenu:

- Calibration of the temperature sensor inputs
- Selection of the input and output types
- Resetting of the menu to factory settings

Menu / Parameter	Setting range	Description
Expert / Configuration / Hardware / <b>Calibration</b>		
E4:EFI ... E15:EFI	-5,0 ... 0,0 ... +5,0 k	Offset calibration of the temperature sensor inputs.

Menu / Parameter	Setting range	Description
...Expert / Configuration / Hardware / <b>Input</b>		
E1:EI ... E3:EI	Digital: OFF/ON	Digital input OFF/ON.
	Digital: OPEN/CLOSED	Digital input OPEN/CLOSED (e.g. valve feedback).
	Digital: PULSE	Pulse input (e.g. pulses from a flowmeter).
E4:EFI ... E12:EFI	KTY2K	Sensor input for KTY temperature sensor.
	PT1000	Sensor input for PT1000 temperature sensor.
	Digital: OFF/ON	Digital input OFF/ON.
	Digital: OPEN/CLOSED	Digital input OPEN/CLOSED (e.g. valve feedback).
	Digital: PULSE	Pulse input (e.g. pulses from a flowmeter).
E13:EFI10V ...	KTY2K	Sensor input for KTY temperature sensor.
E15:EFI10V	PT1000	Sensor input for PT1000 temperature sensor.
	Digital: OFF/ON	Digital input OFF/ON.
	Digital: OPEN/CLOSED	Digital input OPEN/CLOSED (e.g. valve feedback).
	Digital: PULSE	Pulse input (e.g. pulses from a flowmeter).
	I10V Setpoint temp. [°C]	Analogue input 0 ... 10 V for temperature in °C (Setpoint).

Menu / Parameter	Setting range	Description
Expert / Configuration / Hardware / <b>Output</b>		
Test	Off, A1:ARSP...A15:10V	Test function for switching outputs. The selected output is activated. Deactivation takes place by selecting "Off" or automatic after 5 minutes
A14-10V, A15-10V	0-10 V voltage	Analogue output 0 ... 10 V DC

Menu / Parameter	Setting range	Description
Expert / Configuration / Hardware / <b>Output</b>		
	PWM Signal Typ 1	PWM-Output 1KHz, preferably for solar pump
	PWM Signal Typ 2	PWMOutput 500Hz, preferably for heating pump

Menu / Parameter	Setting range	Description
Expert / Configuration / Hardware / <b>Reset</b>		
Reset	Off, set	Resets the menu to the factory settings.

## 9 Function descriptions

### 9.1 General controller functions

#### 9.1.1 Outside temperature measurement and processing

##### Long-term value and the average value of the outside temperature

Three values are used to calculate the effect of the outside temperature on the heating behaviour of the system:

- Actual outside temperature:  
The actual temperature measured by the outside sensor.
- Long-time value outside temperature:  
The long-term value of the outside temperature is required for the summer shutdown and calculation of the outside temperature mean value.  
The long-term value of the outside temperature is calculated as a mean value based on the building type and the actual outside temperature. Every 20 minutes, a new, actual value is entered into the mean value calculation/long-term value creation.
- Outside temperature mean value:  
The mean value outside temperature is required to calculate the Setpoint flow temperature of the heating circuits. The mean value outside temperature is the arithmetic mean of the actual outside temperature and the long-term value of the outside temperature.

##### Building type

Menu	Parameter	Description
Expert / System	<b>Building</b>	Selection of the building type for calculation of the long-term value of the outside temperature.

The selected building type influences the calculation of the *Outside temperature-long term value*. The long-term value of the outside temperature is determined over an adjustable time period (building parameters) whereby a new outside temperature value is recorded every 20 minutes. This value is included in the calculation of the outside temperature mean value.

$T_{OLong} = \sum_{i=1}^n \frac{(T_{OAct})_i}{n}$	n      building type (light: 6h, medium: 24h, heavy: 72h) T <sub>Oact</sub> Actual outside temperature T <sub>Olong</sub> Long-term value of the outside temperature
---	--

##### NOTE

During initial setup of the control unit (long-term value not yet measured), the value is dynamically determined, e.g. after 40 minutes (i=2) an average is determined from the 2 available outside temperature values, after 60 minutes using 3 values, etc.

### Emergency mode outside sensor

Menu	Parameter	Description
Expert / System	Emergency mode outside temperature	Outside temperature setting which is used for control after failure of the outside sensor.

If during weather-compensated operation, the connected outside sensor fails (sensor short circuit or open circuit), the *heatcon!* system continues regulation using the emergency mode temperature set here.

### Assignment outside sensor 2 -> Heating circuit

Menu	Parameter	Description
Expert / Configuration / Extras	Outside sensor 2	Activation of the second outside sensor OS2
Expert / Room 1... 24 Expert / Room group 1...n Basic settings	Outside sensor mapping	Selection of the corresponding outside sensor for the room/room group, if a second outside sensor has been configured.

If a second outside sensor (OS2) has been configured, then optionally the outside sensor OS1, OS2 or the mean value of both sensors can be assigned to the room/room group.

If one sensor is defective, there is an automatic switchover to the remaining outside sensor and a simultaneous fault message. In case of a defect affecting both sensors, the heating circuit is regulated using an adjustable Emergency mode temperature outside temperature according to a set heating curve and heating program taking into consideration the specified mode temperature.

### NOTE

---

#### Alternative connection of the outside sensor at the burner control system

On energy generators with control systems for combustion control or heat Pump control systems, with certain manufacturers it is possible to connect an outside sensor.

This sensor value is received and used by the energy generator data bus of the *heatcon!* system.

---

### Clima zone

Menu	Parameter	Description
Expert / System	Clima zone	Setting of the coldest anticipated outside temperature value.

The *Climate Zone* parameter corresponds to the coldest expected outside temperature. The set temperature is included in the calculation of the Request value.

For the heat demand coverage, this value is used as the basis for the design of the heating system.

## 9.1.2 Frost protection function

### Weather guided frost protection

Menu	Parameter	Description
... / Room (group) / Basic settings	Frost protection	Outside temperature setting for activation of the frost protection function for the room/room group.
	Frost protection mode	Selection of the operation mode for the frost protection function for the room/room group.
... / Room (group) / Standard setting	Frost protection temperature	Room Setpoint temperature setting for frost protection operation.
... / Room (group) / Heating mode	Frost protection cycle	Selection of the operation mode for the frost protection function for the room/room group.

To prevent the heating system from frGENing in switch-off mode, the *heatcon!* system is equipped with electronic frost protection.

- Operation with Outside temperature control:  
If the outside temperature (actual value) drops below the set limit (*Frost Protection*), heating operation is reactivated. Heating mode can be interrupted again when the outside temperature exceeds the set limit by 1 K.
- Operation with Room Temperature Measurement: (*heatapp! drive / sense*)  
The weather guided frost protection also switches the heating circuit Pumps on if room temperature measurement is active, if the temperature fall below the set outside temperature frost limit. This occurs irrespective of whether the room actual temperature falls below the room Setpoint.  
If the room temperature falls below the set room Setpoint, heating operation is resumed.  
The heating is switched off again if the room temperature exceeds the set room Setpoint by 1 K. If, at this moment, the outside temperature is still below the set frGENing limit, only the heating circuit Pumps remain active.

Parameter	Description
Frost protection mode	Selection of the operation mode for the frost protection function for the room/room group. <ul style="list-style-type: none"> <li>- <i>Frost protection temperature</i>: If frost protection is active the deviation control of the room temperature takes place according to the set frost protection temperature.</li> <li>- <i>Set-back temperature</i>: If frost protection is active the regulation of the room temperature takes place according to the set set-back temperature.</li> </ul>

#### NOTE

In conjunction with a second outside sensor, the frost protection function is activated as soon as one of the two outside temperatures drops below the frost protection limit. In the event of a faulty outside sensor, frost protection is constantly activated.

### Frost protection cycle operation

Activation of the frost protection function takes place via the set frost protection limit. The frost protection function is active provided frost protection is active even if there is no Request from the room group/room.

- If frost protection cycle operation is active, there is no continuous Request for the heat generator, in contrast to continuous operation.
- With active system frost protection, the heating circuit Pumps are switched on and the mixer valves closed.
- If the measured flow temperature of the mixed circuits or the heat generator temperature in the direct heating circuit, respectively, does not drop below the current set room temperature ( $RT_{Frost}$  or  $RT_{Night}$ ), no Request value is sent to the heat generator.
- When the flow temperature drops below the Setpoint, heating operation is activated.
- Once the set flow temperature has reached the set room temperature and the set time (*Frost Protection Timing*) has expired, the Request value to the heat generator is retracted and the mixing valve closes while the Pumps continue operation.
- If no measurements are detected from the outside sensor (e.g. becOffe the sensor is defective), only the Pumps are switched on while heating operation is disabled.
- The set minimum and maximum limits are considered during heating operation.
- When the heat generator is activated, the set start-up protection conditions of the heat generator are applied. This means that the heating circuit Pumps may be switched off temporarily.

### Frost protection in the event of a heat generator fault

If a system induced fault message of the energy generator occurs (e.g. switch-on failure of the burner due to fuel shortage or burner malfunction), priority Pump switch-off functions such as boiler start-up protection, hot water priority etc. are disabled if frost protection is active.

The heating water circulated in the heating circuits adopts the overall mean room temperature and reduces or delays any freezing.

## 9.1.3 Anti-lock function

### Forced operation of Pump and mixer (anti-lock protection)

Menu	Parameter	Description
Expert / Domestic hot water / Pump	Anti-lock system	Setting of the run time/opening time for the anti-lock protection of the Pump/valve.
Expert / Domestic hot water / circulation pump		
Expert / Heating buffer / Pump		
Expert / Solar / Pump		

With this function activated all the Pumps are switched on every day for a set period to protect against lock due to corrosion in the event of long switch-off phases (> 24h) and the valves are opened temporarily during this period. This control function is synchronised to 8.00 p.m.

For example, this is the case during summer shutdown.



### 9.1.4 Pump-function

The Pump function offers different options for actuating and controlling a Pump in the heating system.

The following Pumps can be assigned to the function:

- Energy generator Pump (boiler circuit Pump, primary Pump, etc.)
- Return flow control Pump
- Feed pump
- Heating buffer Pump
- DHW Pump
- Heating circuit Pump 1 ... n
- Solar charging Pump
- Solid fuel boiler Pump
- Differential control Pump

All Pumps can be assigned a lead time and a overrun time time.

Menu	Parameter	Description
Expert / Configuration / function	Pump 10V	Assignment 0 ... 10 V output for the Pump
Expert / Configuration / Hardware / Output	A14:10V / A15:10V	Operation mode selection (0 ... 10 V / PWM) for the 0 ... 10 V output
... / ... / Pump	Switch on mode	Selection of the operation mode for the Pump
... / ... / Pump	Output	Pump output setting for <i>constant operation</i> start-up type
... / ... / Pump	Interruption voltage	Pump performance chart setting for <i>temperature spread/Setpoint</i> start-up type.
	Start time	
	Start output	
	Minimum voltage	
	Minimum output	
	Minimum voltage	
	Maximal output	
... / ... / Pump	Gain	PI controller control parameter setting for <i>temperature spread/Setpoint</i> start-up type.
	Adjust time	
	Scan time	

Parameter	Description
Lead time	When the Pump is switched on, the demand to energy management is suppressed for the set lead time.
Overrun time	After removal of the demand, the Pump is switched off after a time delay, e.g. to prevent a safety shut-down of the energy generator at high temperatures.

### Speed controlled Pumps

Speed controlled Pumps receive a speed specification from the *heatcon!* basic controller via a 0 ... 10 V or PWM output.

There are two options for connection of the Pump:

- Speed controlled Pump with external power supply:  
The Pump has a separate external power supply. Actuation is via a 0 ... 10 V output of a *heatcon!* module.
- Speed controlled Pump with switched power supply:  
The Pump is supplied with power via a relay output of the *heatcon!* basic controller. The speed is specified via a 0 ... 10 V output of the *heatcon!* module.

Parameter	Description
Interruption voltage	Adjustment of the output voltage, if the Pump is logically switched off. Even when switched off, some Pump types require a minimum voltage at the 0 ... 10 V input of the Pump.

### Start-up types of speed-controlled Pumps

Speed controlled Pumps can be operated with three start-up types.

Parameter	Description
Switch on mode	Selection of the operation mode for the heating circuit Pump. Constant operation, temperature spread, Setpoint

- Constant operation:  
Upon demand, the Pump is actuated with a constant power value. No temperature values are required for this start-up type. The Pump power is set via the *Power* parameter.

- Temperature spread:

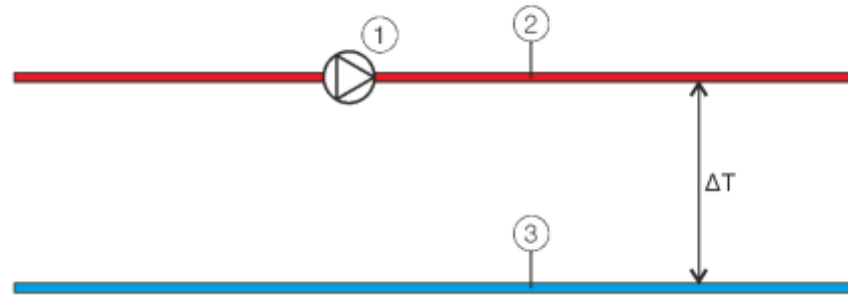
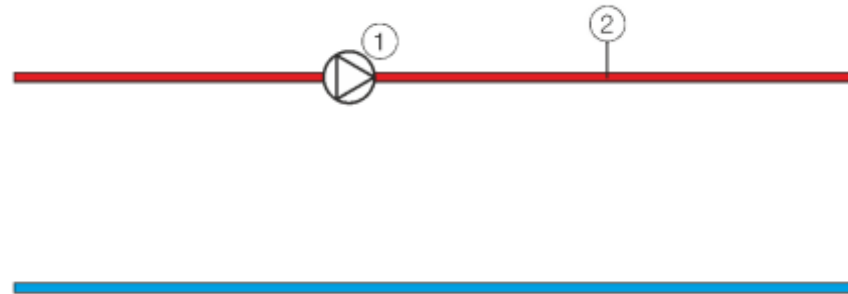

*Fig. 28: Temperature spread*

A speed-controlled Pump (1) can be used for spread regulation control of the corresponding heating circuit via the PI-controller function. In doing so, the Pump speed is adjusted based on a specified spread ( $\Delta T$ ) between the flow sensor (2) and return flow sensor (3) of the heating circuit.

- If the temperature spread between the flow and return flow sensors increases (greater energy consumption), the Pump speed is increased by the PI controller.
- If the temperature spread between the flow and return flow sensors decreases (lower energy consumption), the Pump speed is decreased by the PI controller.

Setpoint:



*Fig. 29: Setpoint control*

In Setpoint start-up type (e.g. heating circuit), speed control can be used to adjust the Setpoint. The control algorithm is conceived so that a specified differential relative to the flow Setpoint and flow actual value is compensated.

- If the Setpoint is exceeded (increased energy consumption), the Pump speed is increased by the PI controller.
- If the Setpoint is undershot (decreased energy consumption), the Pump speed is decreased by the PI controller.

### Pump performance chart

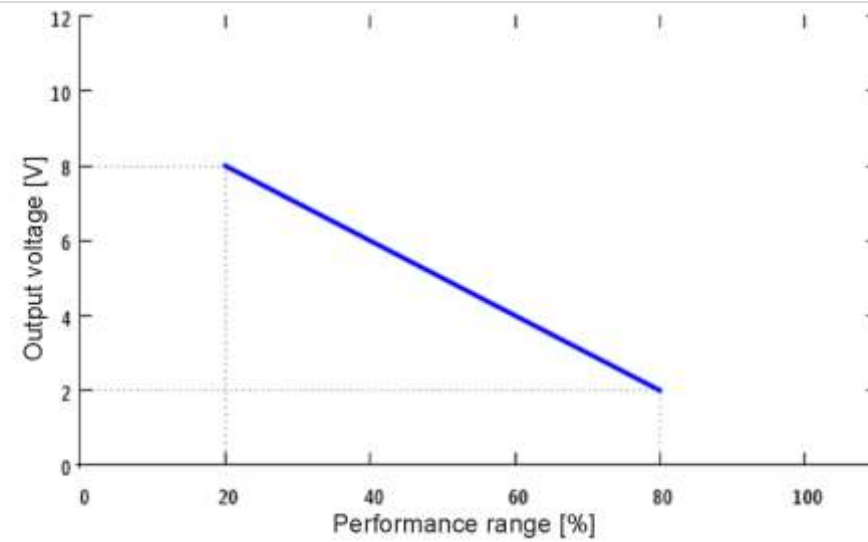
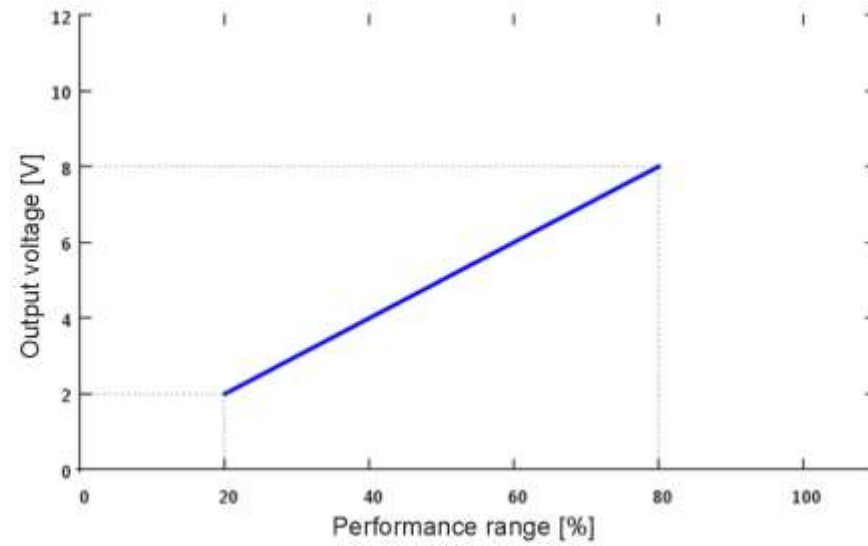

Fig. 30: Performance chart of a speed-controlled Pump (example)

Each speed-controlled Pump operates with a characteristic diagram defined by the four parameters shown in Fig. 30. These parameters specify the minimum voltage for minimum power and the maximum voltage for maximum power. The working range of the Pump (position of the straight line in the diagram) can be adjusted individually using the four parameters. The percentage values are used by the PI controller as a limit. The power signal from the PI controller is converted proportionally to the working area.

For $V_{Max} > V_{Min}$ applies	For $V_{Max} < V_{Min}$ applies
$V_{setp} = \frac{(P_{setp} - P_{min}) \times (V_{Max} - V_{Min})}{(P_{Max} - P_{min})} + V_{Min}$	$V_{setp} = \frac{(P_{setp} - P_{min}) \times (V_{Min} - V_{Max})}{(P_{Max} - P_{min})} - V_{Min}$
$V_{SETP}$ :	Voltage value 0-10V
$P_{SETP}$ :	Power Setpoint from PI controller/Start Value
$P_{Min}$ :	Minimum power Setpoint for PI control
$P_{Max}$ :	Maximum power Setpoint for PI control
$V_{Min}$ :	Minimum output voltage 0-10V
$V_{Max}$ :	Maximum output voltage 0-10V

Parameter	Description
Interruption voltage	Adjustment of the output voltage, if the Pump is logically switched off. Even when switched off, some Pump types require a minimum voltage at the 0 ... 10 V input of the Pump.
Start time	Start time setting for the 0 ... 10 V output of the Pump. The 0 ... 10 V output is activated with the power set in the <i>Start Power</i> parameter for the set time, to ensure a safe start up of the Pump. The PI controller only acts after this time has elapsed.
Start output	Starting power setting for the 0 ... 10 V output of the Pump, for the duration of the set <i>Start Time</i> .
Minimum voltage ( $V_{Min}$ )	Minimum voltage setting of the Pump.
Minimum output ( $P_{Min}$ )	Minimum power setting of the Pump
Maximum voltage ( $V_{Max}$ )	Maximum voltage setting of the Pump.
Maximal output ( $P_{Max}$ )	Maximum power setting of the Pump

**NOTE**

- The value for the *Cut-off Voltage* parameter may lie outside the performance map.
- The value for the *Start Power* parameter must lie inside the performance map.

**Behaviour in the event of an error**

If *heatcon!* detects a sensor fault, the PI controller is deactivated and the Pump is operated with the set start power.

**9.1.5 Heat balancing**

Menu	Parameter	Description
... / Configuration / Function / ...	Heat quantity function (HTM)	Selection of the heat meter function type
... / Configuration / Function / ...	Flow sensor (HTM)	Flow/return flow sensor assignment for heat meter type constant volume flow, volume flow, flow measurement, pulse measurement
	Return flow sensor (HTM)	
... / Configuration / Hardware / Input	Exx:ISP, Exx:PI, Exx:ISP10V	Selection of the input type for the flow measurement
... / Configuration / Hardware / Curve	Minimum voltage	Performance map setting for flow measurement.
	Minimum limit	
	Maximum voltage	
	Maximum limitation	
... / ... / Heat balance	Medium density	Parameter settings for the heat transfer medium
... / Energy generator / Heat balance	Medium heat capacity	Individual setting der Parameter für das Wärmeträgermedium
	Output	Output power setting of the energy generator
... / Configuration / Function / ...	Heat quantity function (HTM)	Selection of the heat meter function type

The *heatcon!* system can calculate the heat balance from the temperature difference between two temperature sensor and the volume flow in the corresponding regulation circuit.

Heat balance is available in the following functions:

- Energy generator
- Domestic hot water
- Heating circuit
- Solar
- Solid fuel
- Difference

The information submenu is used to display the actual heating output in kW and the consumed heat energy in kWh.

#### **NOTE**

---

When displaying the actual output, fluctuations in the displayed value can result due to the system.

---

#### **Constant volume flow heat meter**

If no physical heat meter has been connected to a pulse or 0-10V input, the heat energy can be approximately determined by assuming a constant flow rate.

The temperatures measured at the flow and return are used for the calculation.

#### **Heat quantity via flow / pulse input**

The volume flow based heat consumption measurement is used if a pulse or voltage input has been configured for flow measurement.

The measured volume flow in the heating circuit and the measured temperature difference are used for the calculation. The calculation is much more accurate than with the time-based heat consumption measurement.

- Flow rate value acquisition via pulse input

The flow meter is connected to a free input that can process the maximum pulse frequency of the flowmeter. The input type must be configured as "*Digital: PULSE*".

#### **Heat quantity via runtime (Energy generator only)**

With multi-stage (single stage/two-stage burners) the heat energy can be determined approximately from the runtime. To do so, the parametrised burner output is summed over the runtime of the stage.

## 9.2 Energy/heat generation

The ever increasing proportion of renewable energy generators requires a rethink in respect of the worthwhile, from an energy point of view, combination of different energy types where actuation and control of the “heat generator” is concerned.

Open combination options are required, that cover different requirements in respect of heating operation, DHW charging and even cooling operation.

Against this background, in future the generic term “energy generator (GEN)” will be used in this context, and will replace the terms used up until now, namely “heat generator” or “boiler”.

Energy generator (GEN)	Gas, oil, solid fuel boiler, heat Pumps, etc.
Energy sources	Active and passive energy generators
Energy manager (EGM)	Higher ranking cascade manager
Level manager (FCT)	Internal cascade manager in <i>heatcon! EC</i>

### 9.2.1 Energy manager

Also within an energy generator control unit various combinations of energy types are currently used together.

Thus for example within a heat Pump, additional electric booster heaters or an additional gas heater are used alongside the pure heat Pump stages (one or two-stage).

With *heatcon!*, these different options are controlled by the energy manager.

#### 9.2.1.1 Level manager

Menu	Parameter	Description
Expert / Energy generator / Basic settings	Basic load offset	Basic settings for the stage manager
Expert / Energy generator / Heating	Switch-on delay Switch-off delay Switching difference Hysteresis	Level manager settings in heating operation
Expert / Energy generator / Domestic hot water	Basic load offset Switch-on delay Switch-off delay Switching difference Hysteresis	Level manager settings in DHW operation

The stage manager controls switching on and off of the stages within a *heatcon! EC*.



The conditions for switching on and off can be set differently for operation in respect of heating demands and DHW demands for each energy generator. Generally, switching on and off take place in combination with a saved time delay and due to current difference between Setpoint and actual temperatures.

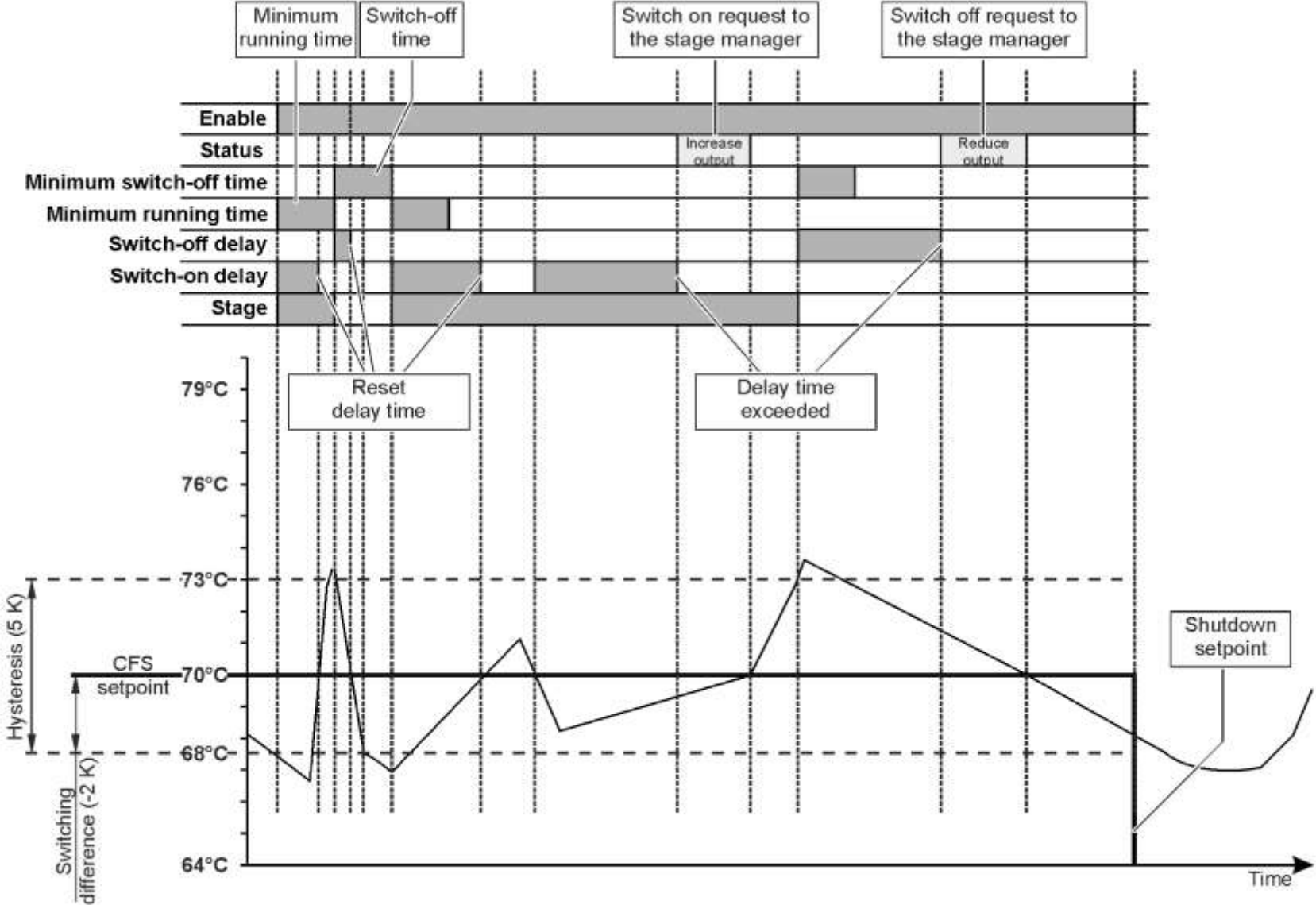

Fig. 31: Level manager

**Basic principle:**

- Each stage of the energy generator is able, within the stage manager, to Request the connection of another stage or the reduction of its own output.
- In this respect, the stage manager only evaluates the demand of the currently regulating stage (leading stage).
- The stage manager decides whether another stage is required or whether the regulating stage can be switched off via the evaluation of switching on and off delay times and switching differences (difference between Setpoint and actual temperature).

**Basic settings for energy generators:**

- *Basic load increase:*  
If more than one energy generator stage is operating, the non-compensating stages form the base load stage. So that these stages do not shut down because of their own switch settings and remain operating, their Setpoint has a shift value applied to it.

**Separate settings for heating and DHW demands:**

- *Switch-on delay:*  
When the compensating stage switches on (switching difference undershot) this delay time starts to elapse. If the actual temperature has not reached the Setpoint within the delay time, a switch on Request is generated on the stage manager.
- *Switch-off delay:*  
When the compensating stage switches off (switching difference + hysteresis exceeded) this delay time starts to elapse. If the actual temperature has not undershot the Setpoint within the delay time, a switch off Request is generated on the stage manager.
- *Switching difference:*  
The stage switches on when actual temperature < Setpoint temperature - switching difference
- *Hysteresis:*  
The stage switches off, when actual temperature > Setpoint temperature + hysteresis

**9.2.1.2 Mini cascade**

Within every heatcon! EC, two energy generators can be selected and operated as mini cascades. The combination possibilities of the energy generators are limited by the hardware design.

Generally, only one 2-stage burner or only one modulating burner can be connected to a heatcon! EC due to the available potential-free outputs!

To simplify the pin assignment, the following restrictions are made:

The energy generator-2 in the device can only be single-stage burner (relay / BUS / 0-10V / PWM)

A 2-stage burner must always be configured as an energy generator 1

A modulating burner (relay OPEN/CLOSED) must always be configured as an energy generator 1.

Possible energy generator configuration:

Energy generator 1	Energy generator 2
1-stage	1-stage
	Automat (Bus)
	0-10V (Setpoint)
	Switching contact
	Modulation 0-10V
2-stage	Automat (Bus)
	0-10V (Setpoint)
Modulation ON/OFF	Automat (Bus)
	0-10V (Setpoint)
Automat (Bus)	1-stage
	0-10V (Setpoint)
	Switching contact
	Modulation 0-10V
0-10V (Setpoint)	1-stage
	Automat (Bus)
	0-10V (Setpoint)
	Switching contact
	Modulation 0-10V
Switching contact	1-stage
	Automat (Bus)
	0-10V (Setpoint)
	Switching contact
	Modulation 0-10V
Modulation 0-10V	1-stage

Energy generator 1	Energy generator 2
	Automat (Bus)
	0-10V (Setpoint)
	Switching contact
	Modulation 0-10V

Due to the defined hardware restrictions, the second energy generator (Energy generator 2) must always be connected to the same IO's.

GEN-2 Switching contact	A3	ASP
Voltage / PWM	A15	A10V / PWM
Sensor input	E13	KTY

## 9.2.2 Energy generator -types

Menu	Parameter	Description
Expert / Configuration / Function / Energy generator	Function	Selection of the type of energy generator. Off, Single-stage burner, Two-stage burner, Modulation OFF/ON, Burner control system (BUS/OT), Actuator signal 0-10V, Switching contact, Modulation 0-10V

A choice can be made between seven different energy generator types.

### 9.2.2.1 Energy generator -type – single stage / two stage

The classical actuation of single or two-stage energy generators takes place via potential-free relay outputs.

The connection and disconnection of the stages takes place via the stage manager, taking into account the general and differentiated energy generator functions.

### 9.2.2.2 Energy generator -type – Burner control system (OpenTherm-Protocol)

The heatcon! system supports communication with OpenTherm enabled energy generators via the openTherm Protocol Specification v4.0.

Data exchange only takes place via the OpenTherm protocol variant OT\_PLUS.

The transmission status is stored with each data point (data index) of the OpenTherm protocol. This allows control of the individual functions (such as DHW temperature indication). Only if a value has been correctly read in, is the corresponding function available.

#### External Setpoint limiting

The OT protocol enables an external specification of the DHW Setpoint and boiler maximum temperature. Within the operation, range monitoring of the set values is performed using the limit values transmitted by the control system (OT slave):

- *Starting phase:*  
The actual boiler minimum and maximum temperatures of the control units are transferred to the program upon each start-up (basic configuration of the control unit). In doing so, the internal limit values are automatically limited to the values on the control units, which ensures that the demand values lie within the specified limit values. This is true for both the DHW night and DHW maximum temperature as well as for the boiler minimum and boiler maximum temperatures.
- *Domestic hot water:*  
The *Night Setpoint* parameter within the DHW menu has been expanded with the *Off* setting. Consequently, a total switching off of DHW charging can be set. This may be necessary because the DHW temperature (control system-specific) can only be set between certain limits (40 ... 65 °C). As a set-back temperature of 40°C may not be sufficient, total switching off is provided as an option here. Setting of the DHW maximum temperature takes place with the setting limits that are specified by the Outside temperature control systems.
- *Energy generator:*  
The minimum limit and maximum limit set values of the heat generator are read out and used as limit values for the setting if this is supported by the OT heat generator.

#### OpenTherm fault messages

The OpenTherm fault messages (ID 05) are read out and displayed as fault messages with a time stamp in the *heatcon!* system.

- *Timeout:*  
If an energy generator type of *Control system (OpenTherm)* has been selected and if there is no connection to the control system (OpenTherm slave), then the fault message "Interface Is broken" is output after 60 seconds. The LED on the *heatcon! EC* goes a steady red. The actual message is displayed in the *heatapp! App* or in the PC user interface.
- *Fault messages:*  
The fault messages (ID 5 HSB) *Service (1)*, *Lockout-Reset (2)*, *Low water press (3)*, *Gas/flame fault (4)*, *Air press fault (5)* and *Water over-temp (6)* are displayed with the standard text "Energy generator with the message xx" and the corresponding number code in the *heatapp! App* or in PC user interface.
- Interlock messages (ID 5 LSB) are displayed as a number code, if a code (ID 0 LSB Bit 0) is set.

#### OpenTherm heating circuit control

The heating circuit control of OpenTherm is used by the *heatcon!* system as a Setpoint setting for the internally collected Request values.

The *heatcon!* system determines according to which Setpoint the control system is to work based on the actual requirements from heating zones, heating circuits, storages and buffers or from the cascade manager.

This Setpoint is transferred to the burner control systems via the heating circuit requirement of the OpenTherm protocol.

### OpenTherm Setpoint setting

The heating circuit requirements are determined by the heatcon! system and transferred via the following OpenTherm data points to the burner control systems:

Datenpunkt	Description
ID 0 LB bit 1	0 Heating circuit control in the passive control system
	1 Heating circuit control in the active control system
ID 0 LB bit 3	0 Flame not active
	1 Flame active
ID 0 HB bit 1	0 Requirement heating circuit control switched off
	1 Requirement heating circuit control active
ID 1	Setpoint for active heating circuit control (only effective if the requirement is active)
ID 14	Relative modulation output limitation
ID 17	Actual relative modulation output of the boiler

### OpenTherm minimum charge control

In the control unit has specified a Setpoint and if the burning time (flame ON) is less than 8 minutes, then minimum charge control is switched over.

Then the heat generator is blocked for 10 minutes (Setpoint = 0).

Then the Setpoint is set to the maximum boiler Request value (ext.  $K_{max}$  or 120 °C). As soon as the controller reads the flame bit back, the Request value is reset to the actual requirement Setpoint.

This cOffes the control system to be switched to the minimum output control.

If the heat generator runtime is then less than 8 minutes, blocking again takes place. If the runtime is greater, then charging control is ended, and the heat generator is not blocked.

### Detection – minimum charge control

Minimum charge control is detected by monitoring the flame status (ID 0 LB bit 3).

When the flame is off (ID 0 LB bit 3 = 0) and the feedback of the heating circuit release is active (ID 0 HB bit 0 = 1) and the boiler Setpoint is greater than the minimum Request value (ID 1 > ID 49 LB), then a minimum charge control must be activated by the controller (master).

### Switching between temperature and capacity control

As soon as low charge has been detected, the controller (master) must switch over from temperature control to capacity control. In doing so, the boiler output is specified (ID 14).

### Monitoring of the blocking time with minimum charge control

During the blocking time, the boiler is completely switched off (as necessary the Pump also). This is done by switching off the heating circuit requirement (ID 0 HB Bit 0). During this time, the Setpoint (ID 1) must be set to the minimum value (0°C).

### Monitoring of the start time (without modulation size ID 14)

During the start time, the heating circuit requirement (ID 0 HB bit 0) is set.

Before the start time begins, the Setpoint (ID 1) is to be set so high that the flame (ID 0 LB bit 3) switches on, or the maximum Request value is set as the Setpoint.

Thereafter, the Setpoint is to be reset to the actual Setpoint or Setpoint -1K. This ensures that the boiler runs with the minimum output.

During automatic increasing of the Setpoint (flame monitoring), the boiler Setpoint should be updated within an interval, so that the boiler does not switch to a higher output stage.

### Monitoring of the start time (with modulation size ID 14)

The heating circuit requirement (ID 0 HB bit 0) is activated, the relative modulation output is set to 0% (ID 14) and the actual heating circuit Setpoint (ID 1) is set to the maximum value.

### Changing back to temperature control

The controller (master) switches back to temperature control if the burning process (active flame) was in uninterrupted operation for at least the specified period (on and off-cycle).

### Automatic tuning to the minimum load balancing

There are energy generators (slave) with minimum load balancing.

In the future, this property must be implemented by all controllers (master), where the activation of this function is controlled by the boiler (slave).

If a boiler has its own minimum charge balancing, then automatic minimum load control must be switched off in the controller (master). This is reported via the slave configuration (ID 3 / HB bit 4) to the master.

Datenpunkt	Description
ID 3 HB bit 4	0 Controller works with automatic minimum load control (algorithm)
	1 Controller works without automatic minimum load control

### Pump control

The OpenTherm protocol has no ID for manual control of the heating circuit Pump. The actual status of the heating circuit Pump is reported via the ID 0 Bit 0. State 1 indicates that the heating circuit Pump is active.

### OpenTherm DHW control

If the burner control system provides DHW heating, the operation can be activated inside the setup wizard.

If the connected OpenTherm unit provides the option of a Setpoint setting for DHW control, the day value and night value for DHW charging can be set inside the control unit.

Additionally the actual DHW Setpoint is indicated inside the information display.

However, if no Setpoint control can be undertaken, then it is also not possible to set any day, night and/or switching time Setpoint.

If a DHW storage charging Pump is available in the *heatcon!* system, it is switched on as long as the DHW signal is transmitted over the OpenTherm bus. Moreover, it is also possible to set priority or parallel operation as the mode of operation.

**NOTE**

Without a Setpoint setting, DHW charging in setback mode and in frost protection mode does not operate!

Datenpunkt	Description
ID0 HB bit1	<p><b>DHW enable</b> This bit enables DHW charging. If this bit is not set, DHW charging remains blocked.</p>
ID0 LB bit2	<p><b>DHW mode</b> The actual state of DHW charging is transferred here. The bit returns a 1 if DHW charging is active.</p>
ID3 HB bit0	<p><b>DHW present</b> If no DHW charging is supported by the burner control system, it issues a 0.</p>
ID3 HB bit3	<p><b>DHW configuration</b> The DHW function can be checked here. Value of 0 indicates an instantaneous water heater system (integrated system) or an "undefined" system. A 1 means that the DHW charging takes place via an external storage.</p>
ID26	<p><b>Domestic Hot Water temperature</b> If actual DHW temperature is not supported by the burner control system, it confirms the data value with DATA_INVALID rather than with RD_ACK.</p>
ID48	<p><b>DHW Setpoint upper &amp; lower bounds for adjustment</b> The external control can specify a DHW Setpoint temperature above these limit values via ID56. If this function is not supported, the burner control system confirms an UNKNOWN_ID upon read-out rather than RD_ACK.</p>
ID56	<p><b>DHW Setpoint</b> The parameter DHW temperature can be set in the burner control system via this data point. Moreover, DHW charging must be activated via the enable bit (ID 0 HB bit1).</p>



### **External water heaters (storages)**

The settings of the external water heater are the same as for the integrated water heater.

#### **NOTE**

---

The ID0 is not written with the WRITE command, rather the corresponding data values are also transferred when a read Request is received.

---

### **Switching output:**

The switching output that can be set within the energy generator level (basic setting) is only available when the "Automatic" energy generator is selected.

If the last burner stage has not been put into operation, all burner stages in operation up to that point are reduced to the specified switching output (output limitation).

When the last burner stage is switched on, all other automatic burner control units are released to 100 % output (full load) after the dynamically determined switch-on delay (at least 5 minutes) has elapsed again.

If the system operates with all available stages, no output limitation is active for the automatic burner control units. If a stage is reduced, the set switching output for the automatic burner control units takes effect again.

### 9.2.2.3 Energy generator -type – Temperature signal 0-10V

Menu	Parameter	Description
... / Energy generator / Output 0-10V	Minimum temperature	Configuration of the performance map on the energy generator.
	Minimum voltage	
	Maximum temperature	
	Maximum voltage	
	Minimum limit	
	Maximum temperature limit	
	Minimum runtime	
	Maximum runtime	
	Break time	

The temperature Request value to the energy generator is output at the 0 ... 10 V output (A14) of the *heatcon! EC* as a voltage value.

The signal conversion corresponds to a linear function  
(0 V = 0°C, 10V = 100°C).

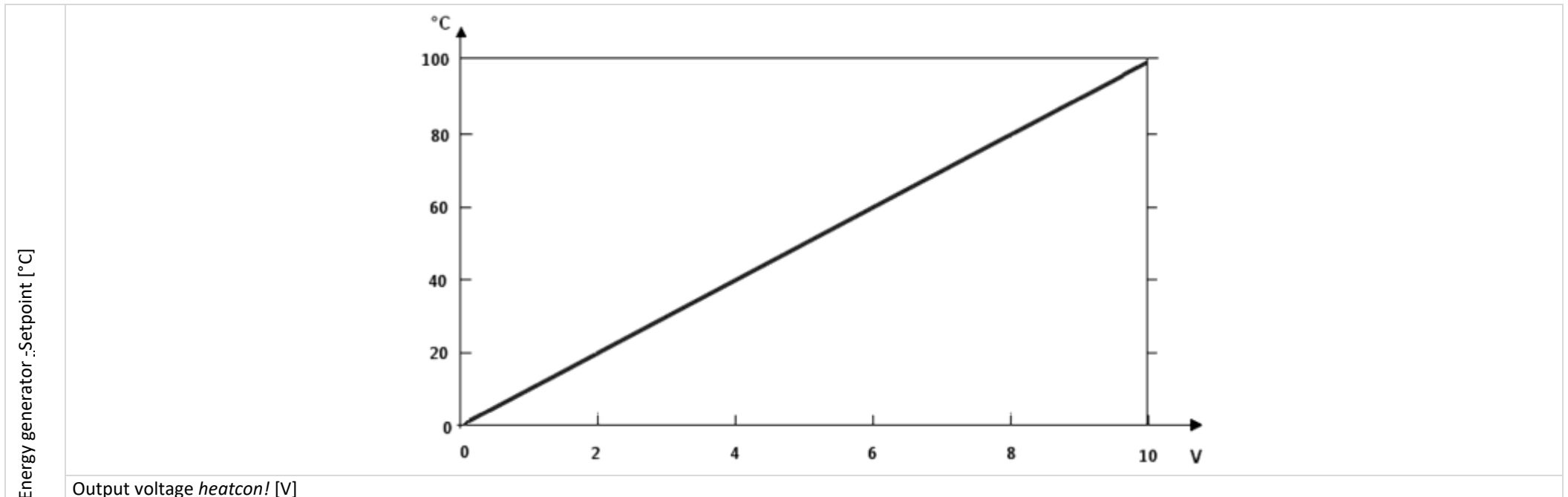

Fig. 32: Performance chart with adaptation to the energy generator

The working performance chart must be adapted to the connected energy generator, it can be changed by an expert.

Based on parameters that are only available after selection of the energy generator type *actuator signal 0-10V*, corresponding minimum/maximum ranges of the actuation can be set and thus matched to the energy generator used.

#### 9.2.2.4 Energy generator -type – Switch contact

If the energy generator works independently without any control possibility via the *heatcon!* control function, the energy generator can be Requested via an enable contact (Request contact of a GEN).

#### 9.2.2.5 Energy generator -type – modulation on/off or modulation 0-10V

Menu	Parameter	Description
... / Energy generator / Modulation	Switch on mode	The start-up type defines the criteria according to which the modulating control should work. <ul style="list-style-type: none"> <li>– <i>Starting output</i>: The set starting output is maintained at a constant level.</li> <li>– <i>Temperature spread</i>: With temperature spread, the flow temperature is regulated based on the return temperature + temperature spread (8K). If there is no heating output (FLOW-RETURN &lt; temperature spread) the system is regulated down. If there is increased heating output (FLOW-RETURN &gt; temperature spread) the system is regulated up.</li> <li>– <i>Setpoint</i>: Stabilisation based on the actual Setpoint difference (actual requirement - actual energy producer current temperature)</li> </ul>
	Start time	This determines the length of the start-up phase in modulation mode so that a stable start-up is ensured. As soon as the set starting time has expired, the modulation switches to its normal control characteristics base on the modulation parameters.
	Start output	Defines an adjustable percentage fraction of the modulation running time during the start-up phase. At a setting of 0%, the actuator valve remains permanently closed during the start-up.
	Minimum limit	Setting of the minimum output during modulation of the energy generator.
	Maximum limitation	Setting of the maximum output during energy generator modulation.
	Runtime	Runtime setting of the actuator for the modulation. The time must be entered that the actuator requires for a movement from 0% to 100% valve opening.
	Regulation gain	Specifies the gain for the PI controller, with which the actuator works.
	Regulation adjust time	Specifies the period in which the residual difference should be balanced out.
	Regulation scan time	Specifies the time interval over which PI control is executed.

The output Setpoint for modulating energy generators can be transmitted either via an OFF-ON signal (2 relays) or via a 0 ... 10 V signal to the energy generator. Here the output control is performed by the *heatcon! EC*.

## 9.2.3 General Energy generator functions

### 9.2.3.1 Start protection

Menu	Parameter	Description
Expert / Energy generator / Basic settings	Temperature start-up protection	Start-up protection temperature setting for the energy generator.
	Switching difference start-up protection	Switching difference setting for deactivating the start-up protection function for the energy generator.

If the set start-up protection temperature is exceeded, the connected consumer circuits are blocked.

Heating circuit Pumps, DHW storage charging Pumps and buffer load Pumps are switched off, mixers are closed.

Start-up protection typically protects a cast-iron boiler against corrosion when it is still cold during the heating-up phase.

### 9.2.3.2 Runtime restrictions/ energy generator blocks

Menu	Parameter	Description
Expert / Energy generator / Basic settings	Minimum runtime	Setting of the minimum stage running time in minutes. Switching off only takes place through an external energy block or if the set maximum temperature is exceeded.
	Maximum runtime	Setting of the maximum stage running time in minutes. The stage is switched off after this time elapses, even if a Request is present. Switching back on can only take place after the set off time.
	Switch-off time	Off time setting in minutes for the stage. Once the stage is switched off, it is blocked for the time set here.
	Summer lock	If the measured outside temperature exceeds the set temperature, all Requests to the energy generator are blocked.
	Winter lock	If the measured outside temperature falls below the set temperature, all Requests to the energy generator are blocked.
	Fault release	Enabling of energy generator if the outside sensor is faulty. <ul style="list-style-type: none"> <li>– <i>ON</i>: Enabling of the energy generator if the outside sensor is faulty</li> <li>– <i>OFF</i>: Blocking of the energy generator if the outside sensor is faulty</li> </ul>

### 9.2.3.3 Forced draining

Menu	Parameter	Description
Expert / Energy generator / Basic settings	Forced draining (target)	Selection of the type of forced draining for the energy generator.
	Forced draining (temperature)	Temperature setting for forced draining activation.

If the set temperature in the energy generator is exceeded, the excess energy is dissipated as configured. This prevents overheating of the energy generator.

DHW, heating circuits, heating buffers (only for configuration with charging control) are possible targets. Alternatively, a relay output can be selected with External, via which the energy can be forwarded via a Pump to a lower level buffer storage.

#### NOTE

---

When assigning of the forced draining, ensure that the hydraulic scheme enables forced dissipation into the selected area.

---

### 9.2.3.4 Flue gas temperature monitoring

Menu	Parameter	Description
Expert / Energy generator / Basic settings	Exhaust gas control	Limit setting for flue gas temperature monitoring. If the limit value is exceeded, the energy generator is blocked for the set blocking time and a fault message is triggered.
	Blocking time	Blocking time setting for flue gas temperature monitoring. <ul style="list-style-type: none"> <li>– <i>Off</i>: Flue gas temperature monitoring is switched off</li> <li>– <i>5 ... 60 min</i>: The energy generator is blocked if the limit is exceeded. If the temperature falls below the limit by more than 5 K, the energy generator remains blocked for the time set here.</li> <li>– <i>SLT</i>: The energy generator is blocked if the limit is exceeded. If the temperature falls below the limit by more than 5 K, the block can be cleared by switching the power supply off and on.</li> </ul>

This function controls the necessary measures when the permitted flue gas temperature is exceeded.

If a sensor error is detected while an exhOfft gas sensor is active and a block was set for a limited time (safety function), a fault message is sent and the heat generator is turned off.

#### NOTE

---

Due to the high temperatures, a PT 1000 sensor is used as the exhOfft gas sensor. The input type of the selected input must be configured as *PT1000*.

---

## 9.2.4 Heating / Domestic hot water

Menu	Parameter	Description
Expert / Energy generator / Heating	Minimum temperature	Minimum Request temperature setting of the energy generator, if a heating Request exists.
	Maximum temperature	Maximum Request temperature setting of the energy generator, if a heating Request exists.
Expert / Energy generator / Domestic hot water	Minimum temperature	Minimum Request temperature setting of the energy generator, if a DHW Request exists.
	Maximum temperature	Setting of the maximum Request temperature of the energy generator, if a DHW Request exists.

For some energy generator functions, a differentiation is necessary based on the type of consumption or energy type. The following consumption or energy types are differentiated:

- Heating mode
- DHW operation

## 9.2.5 Boiler Pump modulating start protection

If the boiler Pump is designed with 0-10V or PWM control signal, a limit temperature for the speed limitation depending on the current boiler temperature can optionally be activated via the "Energy generator / Pump / Start protection" parameter.

Menu	Parameter	Description
Expert / Energy generator / Pump	Start protection	Setting the limit temperature for speed limitation.

### 9.2.5.1 Function

In the background, the Pump determines the maximum permissible Pump speed for the set boiler start protection temperature and thus limits the control signal for the boiler Pump as soon as the energy generator is switched on.

The PI control operates as a function of the current boiler leader flow temperature (actual) to the boiler start protection temperature (Setpoint). The control band is defined by the set minimum and maximum output (for fixed Setpoint controllers by the parameter Output). The Pump capacity determined here serves as a limitation value for the control.

The boiler flow temperature is the lowest boiler temperature if two boiler sensors are registered. The start relief also acts as a limiting value for the "constant operation" switch-on mode.

After starting the Pump, the temperature Expertle is verified by a PI controller. If the temperature drops (against the set starting protection value), the Pump speed is reduced. If the temperature rises again (energy generator is started), the Pump speed is increased again, up to the set fixed value output or the maximum Pump output.

The speed limitation only affects the boiler Pump if the boiler is in operation (flame bit = ON / relay = ON). In the case of staged energy generators, shutdown is prevented until the speed limitation has been lifted again.

#### NOTE

---

*The energy generator remains in operation until the power limitation determined by the start temperature is no longer active.*

---

### 9.2.6 Full load shutdown – minimum charge control

Menu	Parameter	Description
Expert / Energy generator / Basic settings	Full load shutdown	<ul style="list-style-type: none"><li>- Off: No blocking of the GEN</li><li>- 0.5 ... 10 min blocking of the GEN</li></ul>

#### 9.2.6.1 Function

If the control unit has specified a Setpoint and if the burning time (flame ON) is less than 8 minutes, then minimum charge control is switched over. Then the energy generator is locked for the specified time (according to the parameter "Full load regulation") (Setpoint = 0). Then the Setpoint is set to the maximum boiler Request value (ext. KTmax or 120°C). As soon as the regulator reads the flame bit back, the Request value is reset to the actual requirement Setpoint. This cOffes the control system to be switched to the minimum output control.

If the GEN runtime is then less than 8 minutes, blocking again takes place. If the runtime is greater, then charging control is ended, and the GEN is not blocked.

### 9.2.7 Energy generator pums

#### 9.2.7.1 Boiler pump

In order to avoid overheating of the energy generator when it is switched on, the shut-off device (flap) / boiler Pump is activated immediately after a Request is passed on. The energy generator only receives a Request after the lead time has elapsed. After the Request to the energy generator has been cancelled, the shut-off device / boiler Pump remains active for the overrun time, which prevents excessive reheating of the boiler.

Lead time:

Shut off time for the energy generator until the shut-off device / boiler Pump has opened, so that no temperature accumulation occurs.

Overrun time:

Off switching delay for shut-off device / boiler Pump to avoid excessive reheating of the energy generator.

### 9.2.7.2 Parallel heating system approval

In contrast to the boiler Pump, automatic firing systems are also considered.

After **a burner relay** has switched on or **after** an automatic burner control unit reports an active flame detection, the output is immediately switched on as parallel heat generator enable. A lead time is not considered.

After **all burner relays** have switched off or **after** no automatic burner control unit reports an active flame detection any more, the output is switched off with a time delay, observing the set overrun time.

**A time lock (solar or solid) is not explicitly requested.**

**An external heat generator lock is not explicitly requested.**

### 9.2.7.3 Primary Pump

The primary Pump is functionally equivalent to the feed Pump with the following deviations:

- The primary Pump is not released when hot water is required (feed Pump only for heating circuits)
- When connected to a slave controller (EC), only requirements of heating circuits of the corresponding control unit are effective (see function feed Pump).
- The primary Pump switches OFF in DHW priority mode.

The primary Pump is only switched off when there is no longer a heating circuit demand.

### 9.2.8 Return flow hold-up

The return flow maintenance serves to protect the boiler against corrosion. This ensures that the heat generator can pass the dew point quickly. There are various methods for carrying out this return flow maintenance.

To activate the return flow maintenance, a return flow sensor is first activated in the "Return flow" configuration menu. Subsequently, the mode of operation (Pump or mixing valve) can be selected.



### **9.2.8.1 Return Flow Hold-up (RLH) Mixing Valve (Bypass Valve)**

To activate the direct return flow hold-up, a mixing valve must be assigned with the return flow function. The direct return flow hold-up can be carried out via a free mixing valve output. This valve permanently regulates the specified return Setpoint.

The mixer flow sensor of the selected mixing valve circuit serves as the return flow sensor. The mixing valve controls the specified return Setpoint according to the return temperature. The control of the mixing valve to the return Setpoint is permanent, so that after lowered operation the boiler does not discharge any energy into the heating circuits when it is switched on, but this is mixed directly back into the return.

### **9.2.8.2 Return flow hold-up (RLH) Return Pump (bypass Pump)**

To activate the return flow hold-up with return Pump, a free input must be programmed as a return Pump. This is done in the Configuration menu.

The return Pump operates according to the specified return Setpoint with the set return switching difference. The control of the return temperature via the return Pump only takes place as long as the EEZ also has a Request (Setpoint). In lowered operation, no return minimum temperature is monitored. Here a total switch-off takes place. If the Pump has not received a Request within the last 24 hours, a forced switch-on can be parameterized (approx. 20 sec. Pump kick). If the return flow sensor is defective, the return Pump switches on, provided that the EEZ has a Request.

- Return flow Setpoint: Specifies the temperature to which the return flow is maintained. (Unit: °C)
- Return flow switching difference: Specifies the switch-off point of the return Pump as a function of the return temperature. (Unit: K)

### 9.3 Energy generator -Cascade

#### NOTE

A heatcon! EM - GBA is used, when more than two heatcon! EC should be connected or a greater distance between the heatcon! EC is bridged.

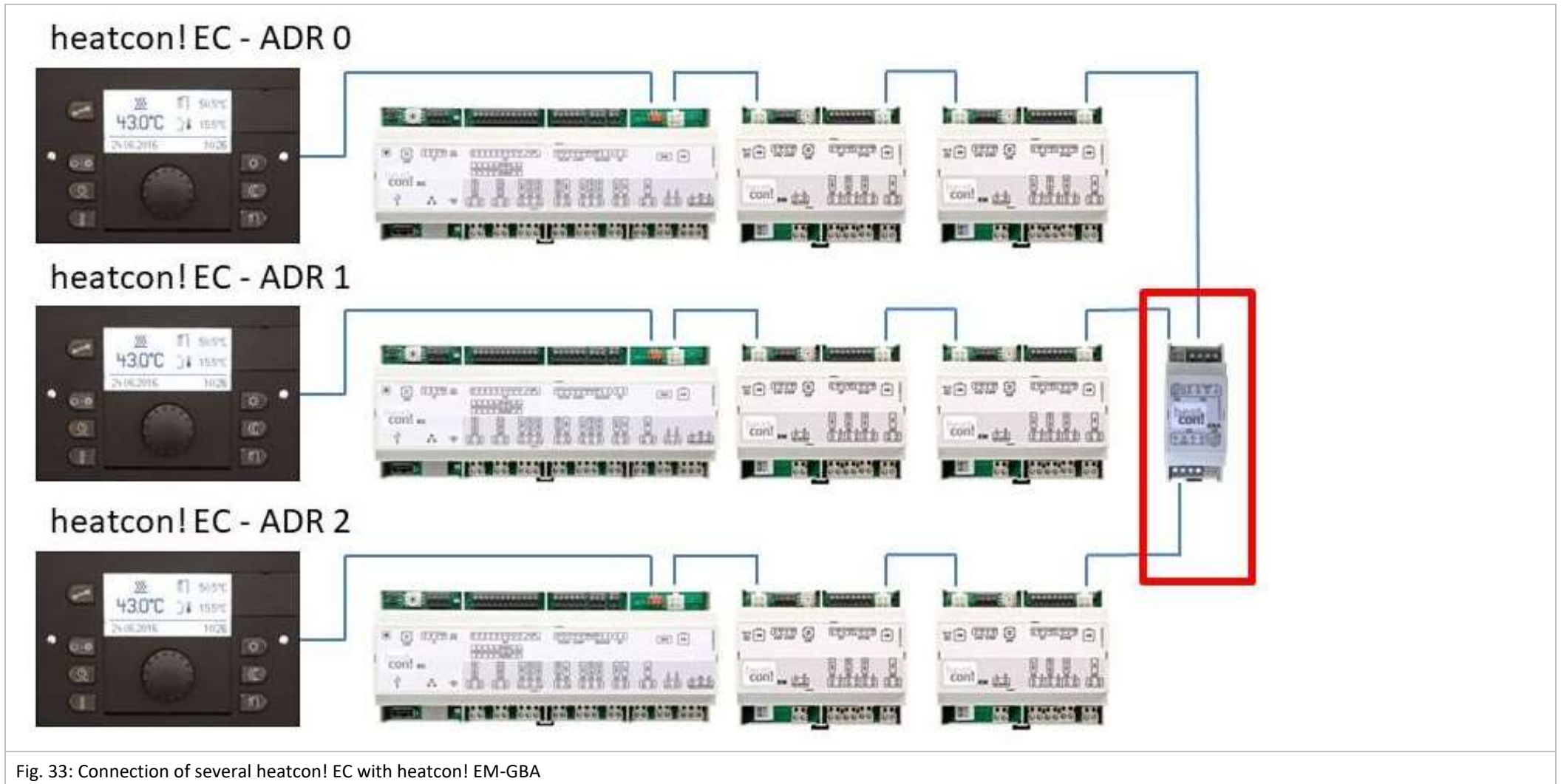

#### NOTE

In an OpenTherm cascade, the heatcon! EC 1351 pro must be used. The connection to the OpenTherm machine is established via the heatcon! Extension module. EM 110 - OT.



Fig. 34: OpenTherm Cascade

On each heatcon! EM 110 - OT, 2 OT energy generators can be connected for a cascade.

The maximum use of 4x heatcon! EM 110 - OT makes it possible to cascade 8 OT energy generators. Fully equipped with 3 heatcon! EC 1351 pro, 24 OT energy generators can be cascaded. For connecting the heatcon! controller is an Extension module heatcon! EM - GBA is necessary.

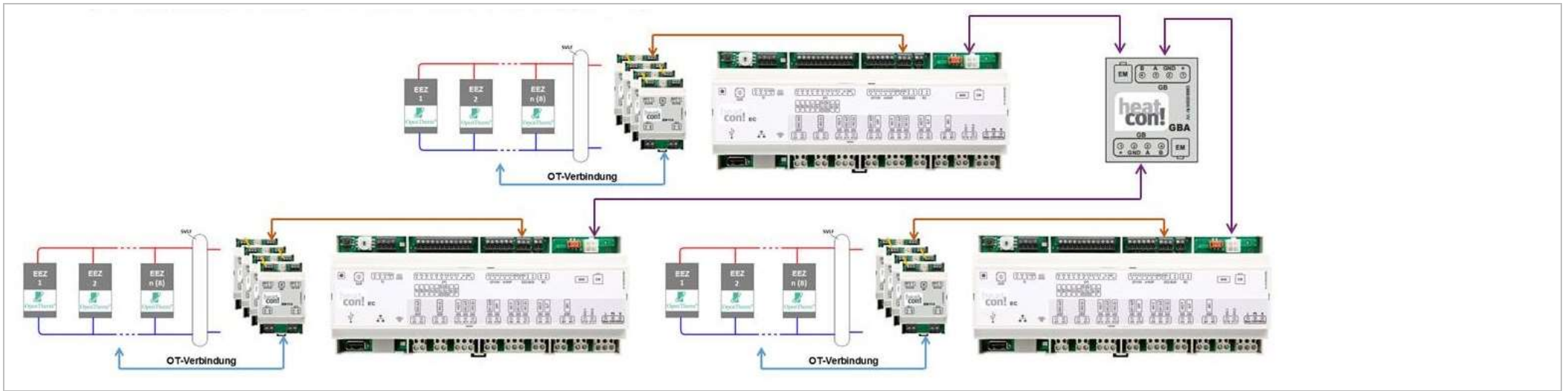

Fig. 35: OpenTherm Cascade fully equipped

### 9.3.1 Cascade parameterization

As soon as the system detects at least two energy generators, the heatcon! EC which performs the master function (heatcon! EC with the lowest address in the system group), the "Cascade" function tree is displayed in front of the energy generators.

### 9.3.2 Information

Heating mode                      current Setpoint from the Request of the heating circuits

Cooling mode                      current Setpoint from the cooling requirement

Hot water mode                    current Setpoint from the Request of hot water

Current temperature              temperature leadlevel / main supply

Runtime of the current control stage

Cascade boiler information 1-40

Display of the current operating states of the energy generators working in the network

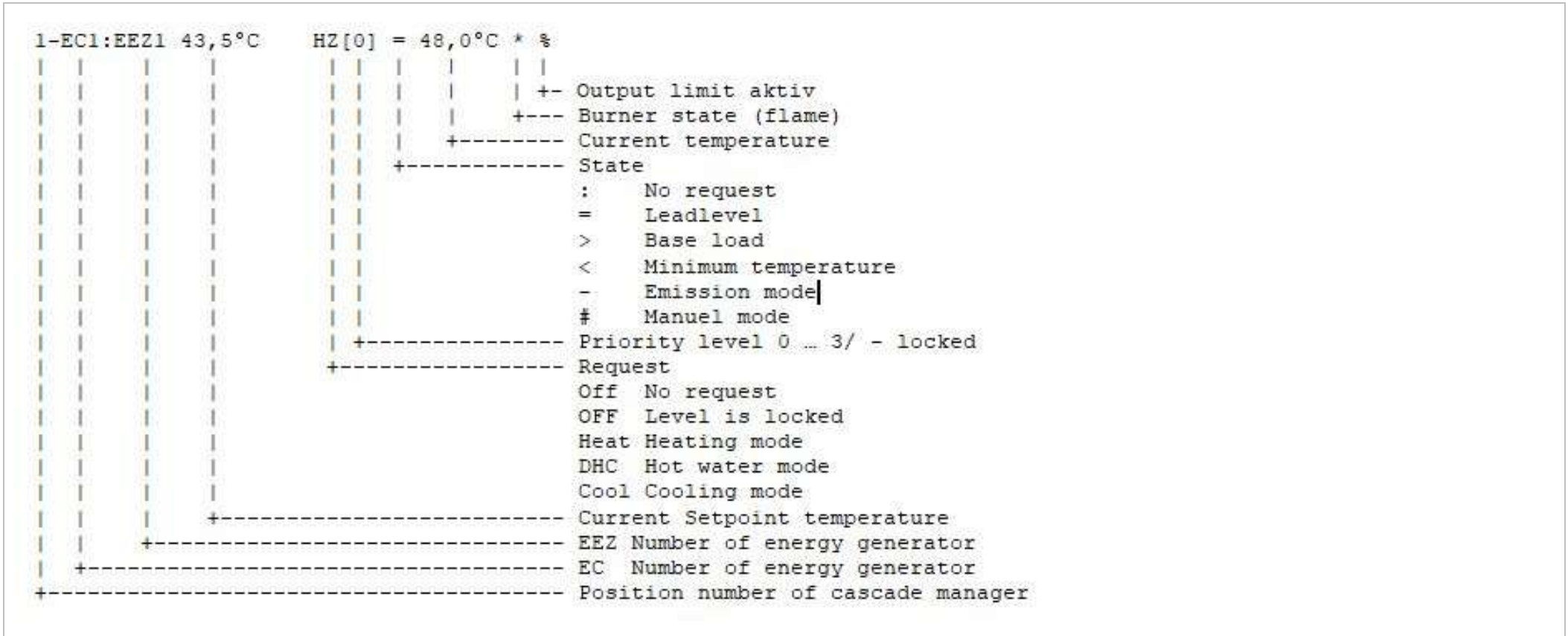

Fig. 36

### 9.3.3 Basic settings

- Control level

The control stage is the energy generator from which the cascade management carries out the stage calculations. The value can be changed manually. With each adjustment, the timer value recorded so far is reset to 0.

- Automatic control stage change

If the current control stage has become active for the operating time set here, the control stage is automatically switched to the next energy generator.

### 9.3.4 Cascade concept

The cascade controls all energy generators in the system centrally. Each energy generator can be individually adapted to the switching behaviour within the cascade network.

#### 9.3.4.1 Control level

All energy generators in the system are controlled according to the heatcon! EC address in a fixed sequence.

---- 1 ----    ---- 2 ----    ---- 3 ----    ---- 4 ----    ---- 5 ----    ---- 6 ----

EC1:GEN1 > EC1: GEN 2 > EC2: GEN 1 > EC2: GEN 2 > EC3: GEN 1 > EC3: GEN 2

**Example:** If the control stage is set to 4, cascade management starts determining the switching sequence from position EC2:GEN2 depending on the selected priority settings.

#### 9.3.4.2 Lead level

There is always only one lead level within a cascade system. This is always the last connected energy source. This monitors the current Setpoint.

#### 9.3.4.3 Base load level

When an energy source is connected, the current lead level becomes the base load level and the newly connected level becomes the new lead level. The base load stage operates with the base load exaggeration parameterised for this energy source.

#### 9.3.4.4 Changeover power (Automat)

As long as not all available machines are enabled, they are limited by the set changeover power. Only when all available machines have been released will the power limitation be lifted.

#### 9.3.4.5 Priorities

The priority setting determines for which requirements the energy source is used as a priority. This allows the switching sequence to be determined independently of the addressing.

### 9.3.5 Requirement management

The cascade management processes a Request (heating / hot water / cooling) from the system network.

The Request is processed according to a fixed priority

Hot Water > Heating > Cooling

This means that a cooling Request can only become active if there is no hot water and no heating Request.

The requirement is formed from all controllers connected in the system network. These make management requirements according to the configured pension assignment.

#### 9.3.5.1 Heating request

All heating requirements from the system are superimposed and the highest requirement is passed on as the Setpoint.

#### 9.3.5.2 Hot water request

All hot water requirements from the system are superimposed and the highest requirement is passed on as the Setpoint.

#### 9.3.5.3 Cooling request

All cooling requirements from the system are superimposed and the lowest requirement is passed on as the Setpoint.

Since only one request (heating / domestic hot water / cooling) can be processed, this is done depending on the selected Cascades request priority.

### 9.3.6 Switching behavior

The functional characteristics of the energy generator depend on the selected energy generator type. The leading energy generator monitors whether an increase or reduction of its output is necessary.

Temperature monitoring depends on the sensor configuration. If a main supply sensor is available, this value is used for switching on or reducing.

Control temperature:

Boiler temperature is lead level

Main supply temperature

Switching on: Control temperature < current Setpoint

Switching off: Control temperature < current Setpoint

The switch-on priority defines the enable position within the cascade control. The priorities OFF, high priority (1), medium priority (2) and low priority (3) can be selected separately for each Setpoint type. The priority OFF blocks the power generator for the selected Setpoint type.

Switch-on or switch-off only occurs when the control temperature for the set switch-on or switch-off delay is below or exceeded. The time is restarted as soon as the switch-on or switch-off condition is no longer fulfilled.

The behaviour can be individually adapted for each requirement type (heating / hot water / cooling).

### 9.3.7 Switching sequence / priority control

The switch-on and requirement priorities are defined individually for each power generator.

#### 9.3.7.1 Switch-on priority heating mode / hot water mode / cooling mode

The switch-on priority defines the enable position within the cascade control. The priorities OFF, high priority (1), medium priority (2) and low priority (3) can be selected separately for each Setpoint type. The priority OFF blocks the power generator for the selected Setpoint type.

	Energy source 1			Energy source 2			Energy source 3		
	ADDRESS 1			ADDRESS 2			ADDRESS 3		
	Priority Request			Priority Request			Priority Request		
	HC	DHW	COOL	HC	DHW	COOL	HC	DHW	COOL
	3	1	Off	1	1	1	2	1	3
Request DHW	1			2			3		
Request HC	3			1			2		
Request COOL	-			1			2		



### 9.3.7.2 Mode – Operation mode

The mode defines whether the energy generator is to be used for control operation or for emergency mode.

In normal operation, the release takes place after configuration. In emergency mode, this stage is only enabled if no other energy generator is available in the system. This stage is not subject to an automatic change of leadership.

**Regular operation:** Energy generator operates in a cascade network.

**Emergency mode:** Energy generator is only enabled if no stage is available in cascade operation.

### 9.3.7.3 Start detection

To start up a boiler defined as "emergency mode", a fault in the control stage must be detected. In the case of non-communicating energy generators, it is possible to determine whether an energy generator is active by recording and off-values of the minimum temperature. Using the parameter in the menu "Energy generator > Basic settings > Start detection", a time can be defined in which this start detection should take place. If the boiler minimum temperature of the control boiler is not exceeded within this set time, this is evaluated as "Energy generator does not start" and an error message "50-3" is generated, this occurs independently of the logical warning message 50-4 or 49-4.

This fault message causes activation of an optionally available emergency boiler in the cascade system.

When the fault message becomes active, the start protection of the control stage in the system is switched off.

The activation or deactivation of the "Emergency mode boiler" is carried out without taking into account a possibly set switch-on and switch-off delay time. The set minimum running time is observed. The energy generator (control stage) which reports the fault remains enabled during this time and detects when the minimum temperature in the control boiler is reached, thus resetting the fault message during operation. The "emergency mode boiler" is taken out of operation again.

The setting range of the parameter " start detection" is

OFF, 1 ... 360 minutes

With the setting value "OFF" no fault signal is generated.

#### Example configuration

Power generator 1 Control operation

Energy generator > Basic setting > Mode = control operation

Power generator > Basic setting > Start detection = Time delay until emergency boiler release

Power generator 2 Emergency mode

Power generator > Basic setting > Mode = Emergency mode

In this example, "Emergency mode" is enabled if the energy generator 1 is switched off due to a defect in the sensor or if "Energy generator does not start".

### **9.3.8 Main supply regulation**

The Setpoint is generated from the Request chain within the system. This Setpoint serves as the basis for the energy requirement.

A PI control regulates automatically the temperature difference between the Setpoint and current temperatures in a preset differential band. This is used for automatic compensation of temperature losses between the measuring points.

The steps are switched on and off based on the current Setpoint deviation.

#### **9.3.8.1 Mode without main supply sensor**

If no main supply sensor is configured, the current flow temperature of the last connected energy generator (lead level) is automatically used as reference.

#### **9.3.8.2 Mode with main supply sensor**

The main supply sensor is used as the reference for the stage switching. Staged energy generators (single-stage burner / two-stage burner) use the main supply temperature as the controlled variable for Setpoint control. The minimum and maximum temperatures are monitored individually in each energy generator according to the boiler sensor(s).

## 9.4 Heating circuit -functions

### 9.4.1 Heating function

Menu	Parameter	Description
Expert / Heating circuit 1...n / Heating mode	Minimum temperature	Minimum temperature setting for the heating circuit. Irrespective of the generated Request, the temperature does not fall below this value. Exceptions: <ul style="list-style-type: none"><li>– If switched off in standby mode above the frost protection limit</li><li>– If switched off in reduced automatic mode with activated ECO function</li><li>– Above the frost protection limit</li><li>– If switched off in permanent reduced mode with activated ECO function</li><li>– In the event of automatic summer shutdown</li></ul>
	Maximum temperature	Maximum temperature setting for the heating circuit. Irrespective of the generated Request, the temperature does not exceed this value
	Increase of Request	This increase is added to the calculated Request value and transferred to the energy source (energy generator, heating buffer, etc.).

A heating circuit is either a Pump (unmixed circuit) or a combination of a mixer and a Pump, that transports the required heat energy to the rooms for heating of the rooms.

The rooms are then heated either by an underfloor heating system or by radiators or by a combination of the two.

As an installation in the *heatcon!* system can have a comprehensive single room control (by incorporation of *heatapp!*) the settings for the heating circuit (at the flow temperature level) and the rooms are strictly separated.

When setting up an installation, the rooms and/or room groups supplied by a heating circuit must be assigned to this heating circuit.

#### ATTENTION

##### Damage to panel heating systems due to high flow temperatures

Overly high flow temperatures can damage panel heating systems (floor, wall, ceiling heating).

To avoid damage, a maximum temperature limiter must be provided that is independent of the *heatcon!* system.

For example this can be a contact thermostat, which switches off the heating circuit Pump if the permitted temperature is exceeded.

### 9.4.2 Heating circuit Pump

For a function description of the heating circuit Pump see section "Pump-function", on page 145.

For a function description of the heating circuit Pump anti-lock function see section "Anti-lock function", on page 144.

### 9.4.3 Mixing valve control

Menu	Parameter	Description
... / Heating circuit 1...n / mixing valve	Regulation gain	Gain setting of the PI controller for the mixing valve of the heating circuit.
	Regulation adjust time	Adjust time setting of the PI controller for the heating circuit mixing valve.
	Regulation scan time	Scan time setting of the PI controller for the mixing valve of the heating circuit.
	Runtime	Runtime setting of the heating circuit mixing valve.
	Stop position deactivation	Selection of whether the mixing valve should be switched off in the limit position.
	Anti-lock system	Runtime setting of the anti-lock system for the mixing valve of the heating circuit

The control of the mixing valves assigned to the heating circuits takes place in the *heatcon!* system via an integrated PI controller.

The following parameters influence the behaviour of the control function. The individual parameters are described in detail in this chapter.

#### Regulation gain (proportional component $Xp$ )

When the nominal temperature changes abruptly, the proportional component  $Xp$  determines the appropriate readjustment of the respective actuator according to the new Setpoint.

#### Example:

An actuator with actuator angle of 90° and a runtime of two minutes is given.

If there is a sudden flow temperature control deviation of 10 K occurs (e.g. when the system switches from reduced to daytime operation) and the gain is 5%/K, the actuator must open by 50 % (= 5%/K x 10K).

Consequently, the duration of the actuation pulse is one minute (= 50 % of the actuator runtime).

#### Regulation adjust time (integral component $Tn$ )

The integral component determines the dynamic behaviour of the controller and thus the time needed by the controller to adjust for a detected deviation from the nominal setting. The integral action time is constant, independent of the size of the deviation.

**Example:**

In the event of a sudden flow temperature control deviation of 10 K (e.g. when the system switches from reduced to daytime operation) and an integral action time of 7 minutes, the controller will adjust for the new (10 K higher) flow temperature after the set time.

The integral action time can be determined using the Ziegler-Nichols method:

1. Close the mixer and heat up the heat generator to the maximum temperature for the heating circuit concerned.
2. Open half of all consumers of the circuit to be measured.
3. Fully open the mixer from the cold state (= room temperature) using the relay test function.
4. Record the temperature change in the heating circuit (flow).

The heating characteristic curve, i.e. the temperature change over time following this action has an inflection point.

The intersection of the tangent through this inflection with the time axis is the delay time. This value multiplied by the factor 3.3 is the optimum integral action time for this heating circuit.

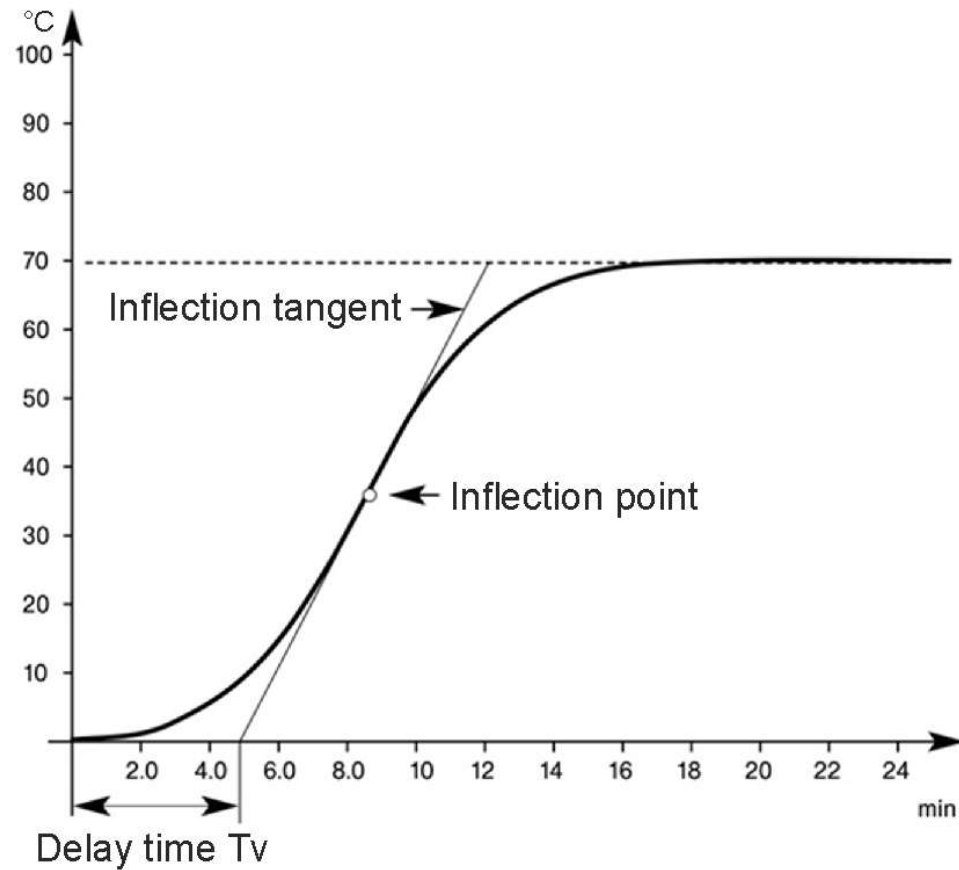

Fig. 37: Heating characteristic curve (example)

In the example (Fig. 37) the heating circuit temperature reaches the value of the heat generator temperature after about 17 minutes, with the mixer fully opened. The curve tangent through the inflection point indicates a delay time of 5 minutes.

Heating system	Adjust time
Underfloor heating systems and other static heating surfaces	10 ... 30 min
Radiator heaters	6 ... 10 min
Convactor heater	3 ... 6 min

### Regulation scan time $T_a$

The sample time is a controller internal quantity that defines the time interval between two subsequent actuator pulses when a control deviation is detected. Shorter sample times result in finer stabilising of the control deviation.

### Actuator run time

This parameter allows adjusting of the actuator with regard to its runtime so that it matches the control characteristics, meaning that actuators with different runtimes (e.g. 1 min, 2 min, 4 min) react to the same control deviation by the same amount by adjusting the action times.

The integral action time  $T_n$  remains unchanged here. However, care must be taken to ensure that the latter must always exceed the runtime of the respective actuator. If necessary, actuators with other runtimes must be used.

### Stop position deactivation

The parameter determines the behaviour of the outputs in the end positions of the actuator.

Selection	Description
Off	Constant voltage at the output in the end positions. When the limit stop of the actuator is reached (0 / 100 %), the actuator is in idle state (STOP). To balance the runtime tolerances, an overrun time of 100 % of the set mixing valve running time elapses after reaching the limit stop.
On	After reaching the end position, the outputs are switched off with a time delay. Just in case, an overrun time of 100 % of the set runtime elapses after reaching the limit stop. This ensures that the valve is at the required limit stop.

**Interaction of P component, I component, integral action time and sample time**

**Step response to different control deviations**  
(open control circuit, actuator pulled off)

Integral action time  $T_n=7$  min.

Sample time  $T_a=20$  sec.

Mixing valve running time = 2min.

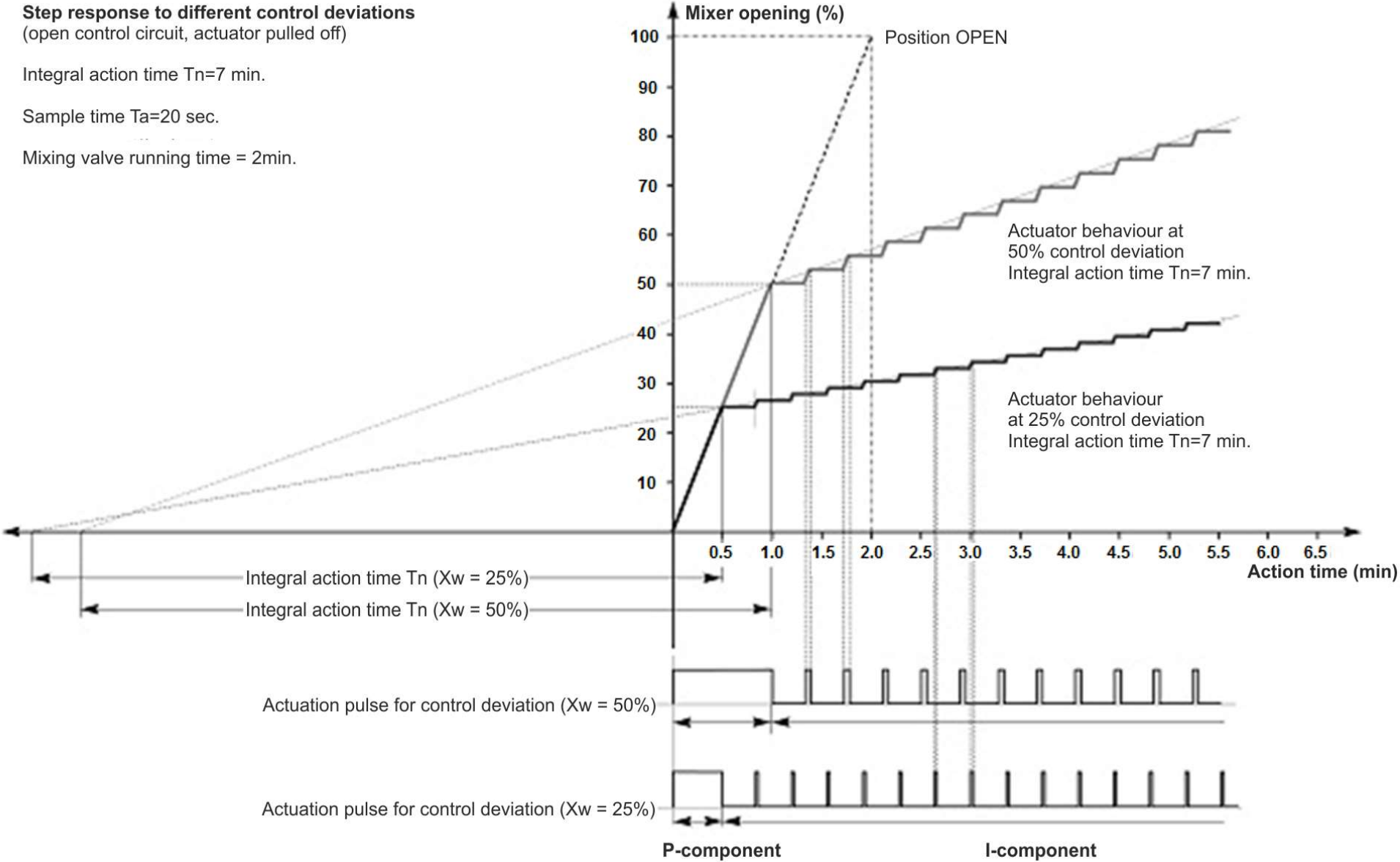

Fig. 38: Example for the interaction of the control parameters



#### 9.4.4 Return flow limitation

A return flow sensor for return flow limitation can be assigned to each mixer-guided heating circuit. The return flow limitation closes the mixer valve when the measured return flow temperature exceeds the specified return flow Setpoint.

#### 9.4.5 Cooling methods of the heatcon! System

The heatcon! System offers three possible cooling methods:

- Passive cooling mode
- Active cooling mode
- Manual room cooling

Depending on the cooling method selected, different conditions are necessary.

#### 9.4.6 Parameter settings passive cooling mode

Menu	Parameter	Description
Expert / Config / Function	Diverter valve cooling (UKP)	Display of the available free outputs. The selection of an output is a necessary condition for a possible cooling function.
Expert / Config / Function / Heizkeis 1 ... n	Supply cool	The heating circuit must be assigned the supply for the cooling function.
Expert / Config / Function / Room group (room)	Supply cool	The room must also be assigned the supply for the cooling function.
Expert / Room group (room)	Cooling mode / colling release	Activation or deactivation of the cooling mode for the room. Activation enables the map characteritic for cooling operation.
Expert / Room group (room)	Cooling mode / Raumfaktor	If a room sensor is used, the room factor can be used to adjust the influence of the room temperature in the Setpoint calculation.
Expert / Room group (room)	Cooling mode / Charateristic map outside minimum	Configuration Charateristic map Cooling mode
Expert / Room group (room)	Cooling mode / Charateristic map outside maximum	Configuration Charateristic map Cooling mode
Expert / Room group (room)	Cooling mode / Charateristic map flow minimum	Configuration Charateristic map Cooling mode
Expert / Room group (room)	Cooling mode / Charateristic map flow maximum	Configuration Charateristic map Cooling mode
Expert / Room group (room)	Cooling mode / Charateristic map room minimum	Configuration Charateristic map Cooling mode

Menu	Parameter	Description
Expert / Room group (room)	Cooling mode / Charateristic map room maximum	Configuration Charateristic map Cooling mode
Expert / Room group (room)	Increase of Request	Setting of the requirement increase for the room. Increase on the Setpoint value for transfer to the cooling circuit.
Expert / Room group (room)	Room thermostat	Off: Cooling is not switched off above Setpoint temperature < actual temperature. <b>0.1 K ... 5.0 K:</b> Setting of the point at which the system stops cooling when the room temperature falls below the Setpoint temperature.
Expert / Heating circuit	Cooling mode / Minimaltemperatur	Minimum temperature limit
Expert / Heating circuit	Cooling mode / maximum temperature	Maximum temperature limitation
Expert / Heating circuit	Increase of Request	Individual setting der Anforderungs-Überhöhung auf den Sollwert zur Weitergabe an den Energieversorger (EEZ oder Puffer).

### 9.4.7 Passive cooling mode

By parametrisation of a passive cooling valve (CHC) the possibility is created for the mixed heating circuit to switch over into passive cooling mode.

To do so, the diverter valve cooling must be assigned to a free output in the menu Configuration – Function.

This function is available to the mixing valve controlled heating circuits as a supply, irrespective of the parametrisation of a cooling source.

Dependent on this activation, further cooling parameters are displayed in the menu room/room group and in the heating circuit menu.

#### 9.4.7.1 Function:

The cooling diverter valve is activated if the averaged outside temperature is greater than the cooling switch-on point (characteristic map outside minimum).

The cooling diverter valve is deactivated again if the outside temperature is less than the cooling switch-on point (characteristic map outside minimum) minus 1K.

If the flow sensor of a mixer heating circuit is defective, the “CLOSE” instead of “STOP” command is issued in cooling mode. The mixer circuit Pump is switched off.

### 9.4.8 Cooling curve

- Depending on outside temperature, the cooling temperature can be changed. For this purpose, a cooling curve is generated.
- The flow cooling curve is always limited by the set minimum cooling temperature (parameter).

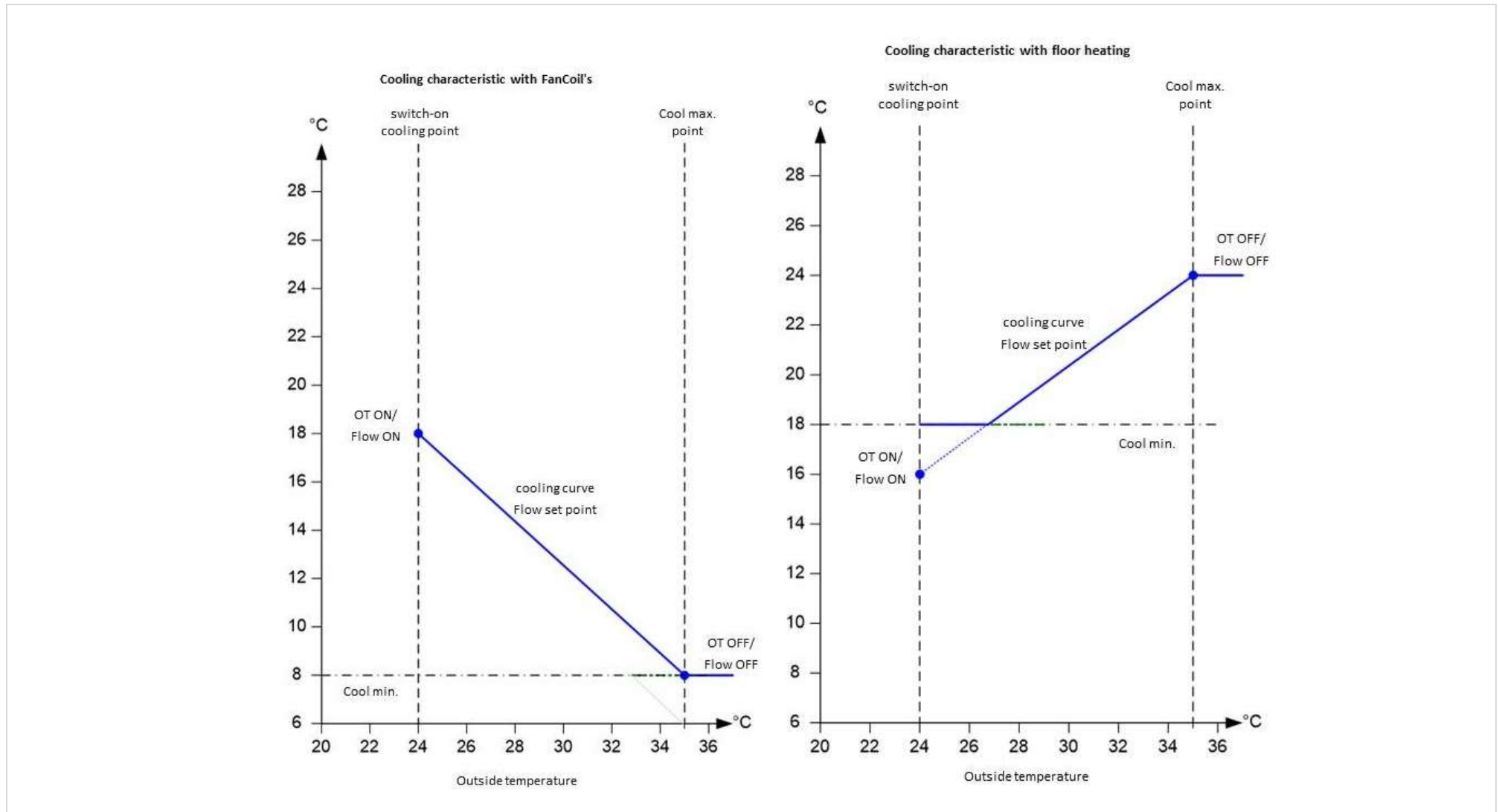

Fig. 39

Point 1 of curve (OT-On / FT-On):<:  
 Point 2 of curve (OT-Off / FT-Off):

Cooling FT setp.temperature for switch-on point / cooling switch-on point OT  
 Cooling FT setp. temperature for max. point / cooling switch-off point OT

### 9.4.9 Calculating room Setpoint temperature

- The room Setpoint temperature to be adjusted, similar to flow temperature, is based on a linear curve, which is determined by two parameters. The current operating point, depending on outside temperature, is the base temperature ( $RT_{\text{setp.-cool1}}$ )
- The end user can set a correction value, which is added to the operating point.  
 $RT_{\text{setp.-cool2}} = RT_{\text{setp.-cool1}} + (RT_{\text{coolingcorrect.Day}} \text{ Or } RT_{\text{coolingcorrect.Night}})$
- The room influence parameter can be used to configure the influence on the current room deviation ( $RT_{\text{setp.}} / RT_{\text{act.}}$ ). Which results in  
 $RT_{\text{setp.-cool3}} = RT_{\text{setp.-cool2}} + RT_{\text{coolingcorrect.Dev.}}$

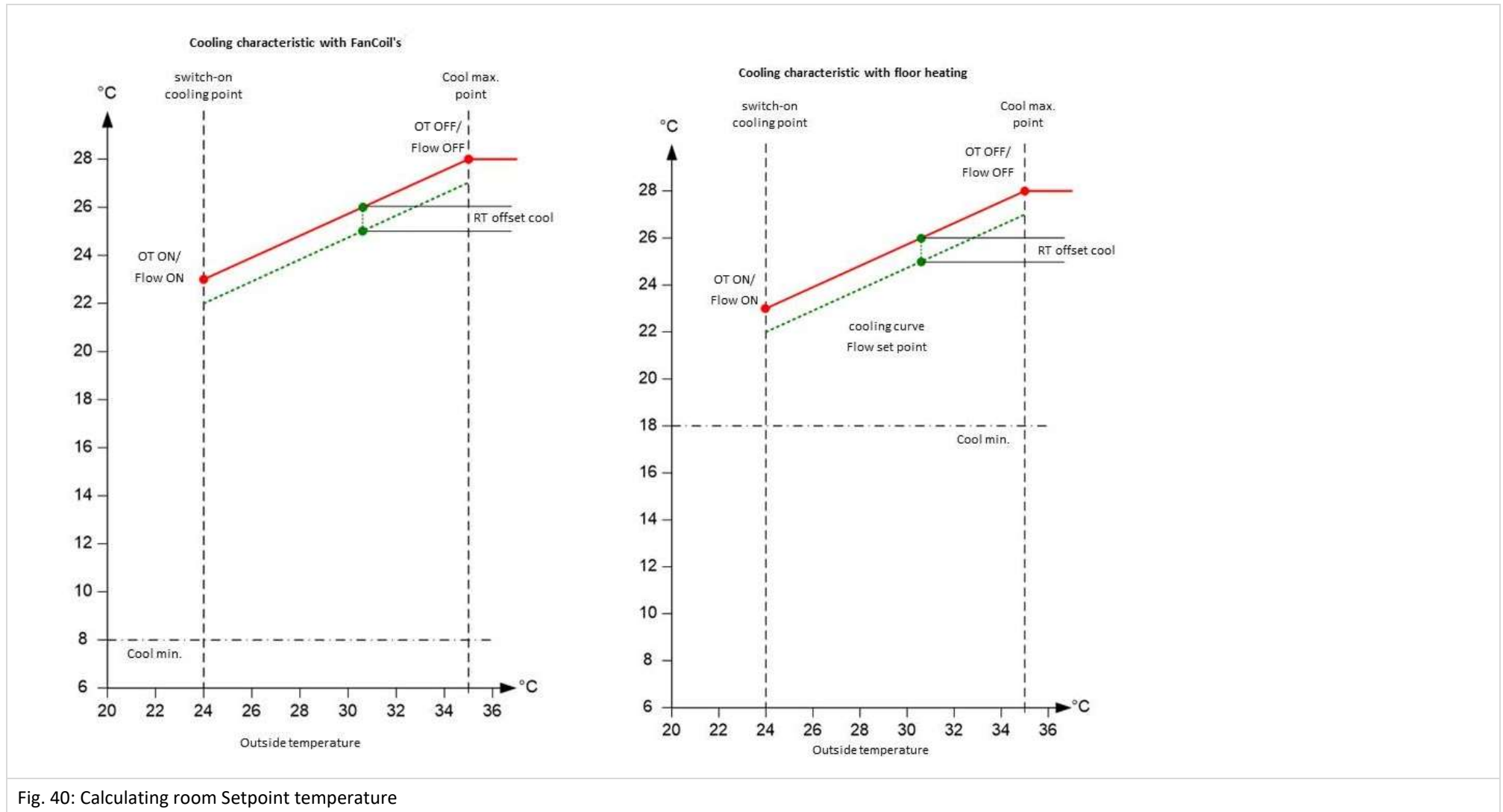

Fig. 40: Calculating room Setpoint temperature

Point 1 of curve (OT-On / FT-On): Cooling room setp.temperature for switch-on point / cooling switch-on point OT  
Point 2 of curve (OT-Off / RT-Off): Cooling room setp.temperature for max. point / cooling switch-off point OT

$$RT_{cooloffset} = RT_{setp.-cool3} - RT_{setp.-cool1}$$

#### 9.4.10 Connection room Setpoint temperature ↔ flow temperature

- Without the influence of a correction value, the flow Setpoint temperature results directly from the flow temperature curve.
- Effective correction values ( $RT_{cooloffset} \neq 0$ ) result in a parallel shift of the flow Setpoint temperature curve according to the room Setpoint temperature to be adjusted based on the deviation from the Setpoint temperature curve.

$$VL_{cooloffset} = RT_{kühloffset} * \left| \frac{VL_{AUS} - VL_{Ein}}{RT_{Aus} - RT_{Ein}} \right|$$

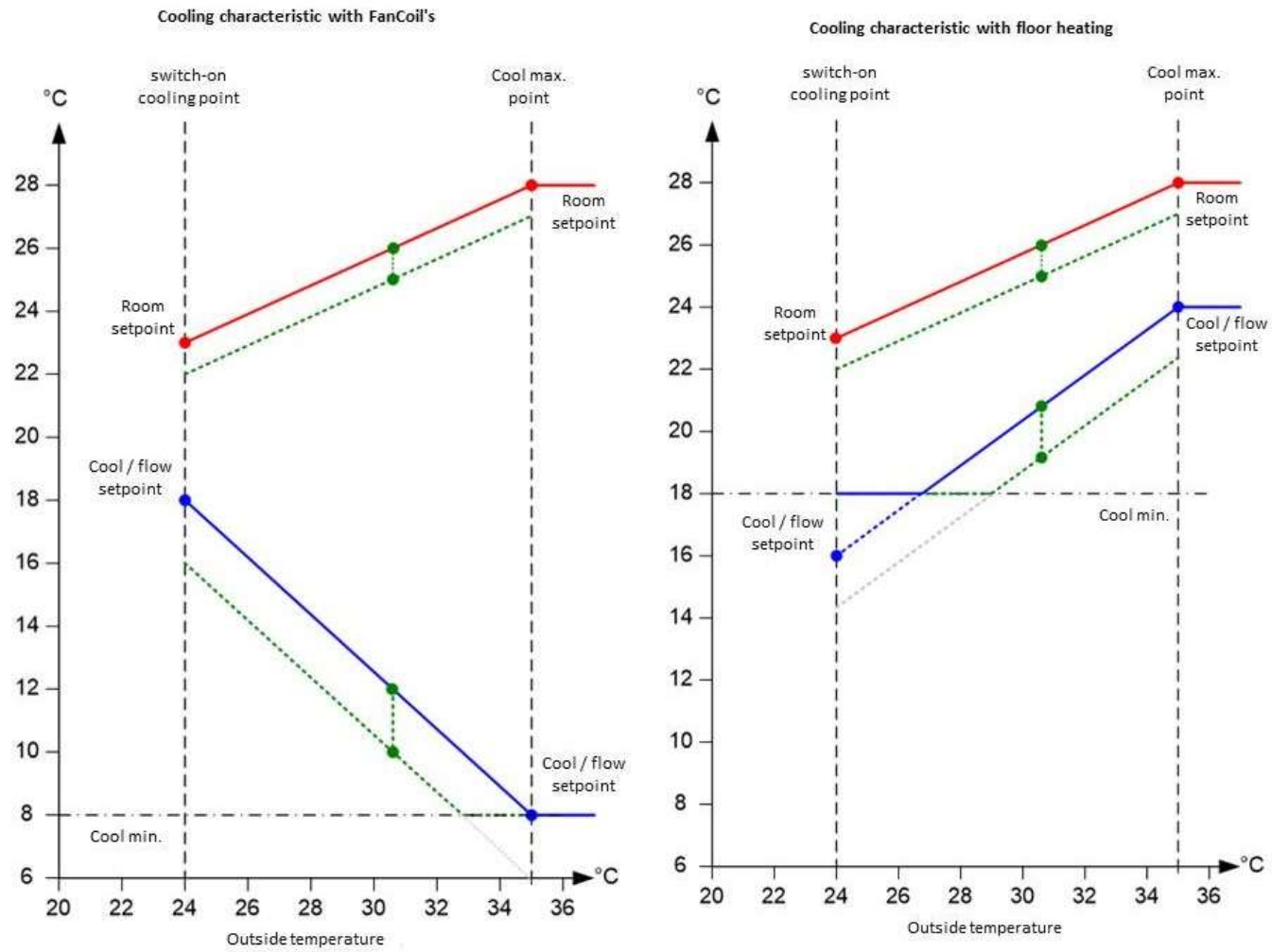

Fig. 41: Connection room Setpoint temperature  $\leftrightarrow$  flow temperature

Green dotted line = example: Room correction -1K

### 9.4.11 Functionality of room unit

If a room unit is connected to a heating circuit, the room influence factors are considered as follows during active cooling:

- Room controller:  
no function during cooling mode. An active room control is interrupted.
- Correction room Setpoint ( $RT_{cooling\ correct.Dev}$ ):  
Analog to heating mode, the Setpoint-actual deviation is added opposite to the cooling Setpoint of the room temperature. The same room factor values apply as in heating mode.
- Thermostat function:  
By setting the thermostat function the cooling mode – analog to heating mode – is interrupted if value drops below limit:

–  $RT_{act} < RT_{setp.-cool2} - SD_{thermostat} \Rightarrow$  Interruption cooling mode

–  $RT_{act} \geq RT_{setp.-cool2} - SD_{thermostat} + 0.5K \Rightarrow$  Cooling mode is resumed

*Adjustment heating circuit:*

- The mixing valve adjusts to Setpoint temperature for cooling mode (see parameter “Cooling Setpoint temperature heating circuit“, heating circuit menu) at flow sensor and – **contrary** to its usual operation – functions as heating controller.

*Emergency mode heating circuit:*

- Emergency mode heating circuit in active cooling mode and sensor defect on FS:  
Pump off, mix.valve closed.

#### NOTE

---

Heating mode has priority over cooling mode, therefore heating mode must be finished to switch to cooling mode. (Summer shutdown, room blocking)

---

*Heat source temperature increase:*

A parametrised heat generator temperature rise is **subtracted** from the cooling Setpoint while cooling mode is active.

*Screed function:*

Cooling mode is not activated when a screed program is active.

### 9.4.12 Active cooling

In order for a heating circuit to be supplied by active cooling, a UKA (changeover valve cooling active) must be parameterised.

The parameterisation is carried out in the Configuration – funktion -energy generator menu.

The output for the cooling function (UKA) works without Pump kick circuit.

### 9.4.13 Parameter settings active cooling mode

Menu	Parameter	Description
Expert / Config / Function	Diverter valve cooling (UKP)	Display of the available free outputs. The selection of an output is a necessary condition for a possible cooling function.
Expert / Config / Function	Energy generator / Diverter valve cooling (UKA)	Display of the available free outputs. The selection of an output is a necessary condition for an active cooling function.
Expert / Config / Function / Heizkeis 1 ... n	Supply cool	The heating circuit must be assigned the supply for the cooling function.
Expert / Config / Function / Room group (room)	Supply cool	The room must also be assigned the supply for the cooling function.
Expert / Room group (room)	Cooling mode / colling release	Activation or deactivation of the cooling mode for the room. Activation enables the map characteritic for cooling operation.
Expert / Room group (room)	Cooling mode / Raumfaktor	If a room sensor is used, the room factor can be used to adjust the influence of the room temperature in the Setpoint calculation.
Expert / Room group (room)	Cooling mode / Charateristic map outside minimum	Configuration Charateristic map Cooling mode
Expert / Room group (room)	Cooling mode / Charateristic map outside maximum	Configuration Charateristic map Cooling mode
Expert / Room group (room)	Cooling mode / Charateristic map flow minimum	Configuration Charateristic map Cooling mode
Expert / Room group (room)	Cooling mode / Charateristic map flow maximum	Configuration Charateristic map Cooling mode
Expert / Room group (room)	Cooling mode / Charateristic map room minimum	Configuration Charateristic map Cooling mode
Expert / Room group (room)	Cooling mode / Charateristic map room maximum	Configuration Charateristic map Cooling mode
Expert / Room group (room)	Increase of Request	Setting of the requirement increase for the room. Increase on the Setpoint value for transfer to the cooling circuit.
Expert / Room group (room)	Room thermostat	Off: Cooling is not switched off above Setpoint temperature < actual temperature. <b>0.1 K ... 5.0 K</b> : Setting of the point at which the system stops cooling when the room temperature falls below the Setpoint temperature.
Expert / Heating circuit	Cooling mode / Minimaltemperatur	Minimum temperature limit



<b>Menu</b>	<b>Parameter</b>	<b>Description</b>
Expert / Heating circuit	Cooling mode / maximum temperature	Maximum temperature limitation
Expert / Heating circuit	Increase of Request	Adjustment of the Request increase to the Setpoint for transfer to the energy supplier (EEZ or buffer).
Expert / Energy generator	Cooling / minimum temperature	Setting of the minimum cooling temperature
Expert / Energy generator	Cooling / maximum temperature	Setting of the maximum cooling temperature

#### 9.4.14 Cooling (app)

An active cooling function (passive or active cooling) is represented in the app by an ice crystal in the room/room group image and a blue swirl around the rotary wheel setting.

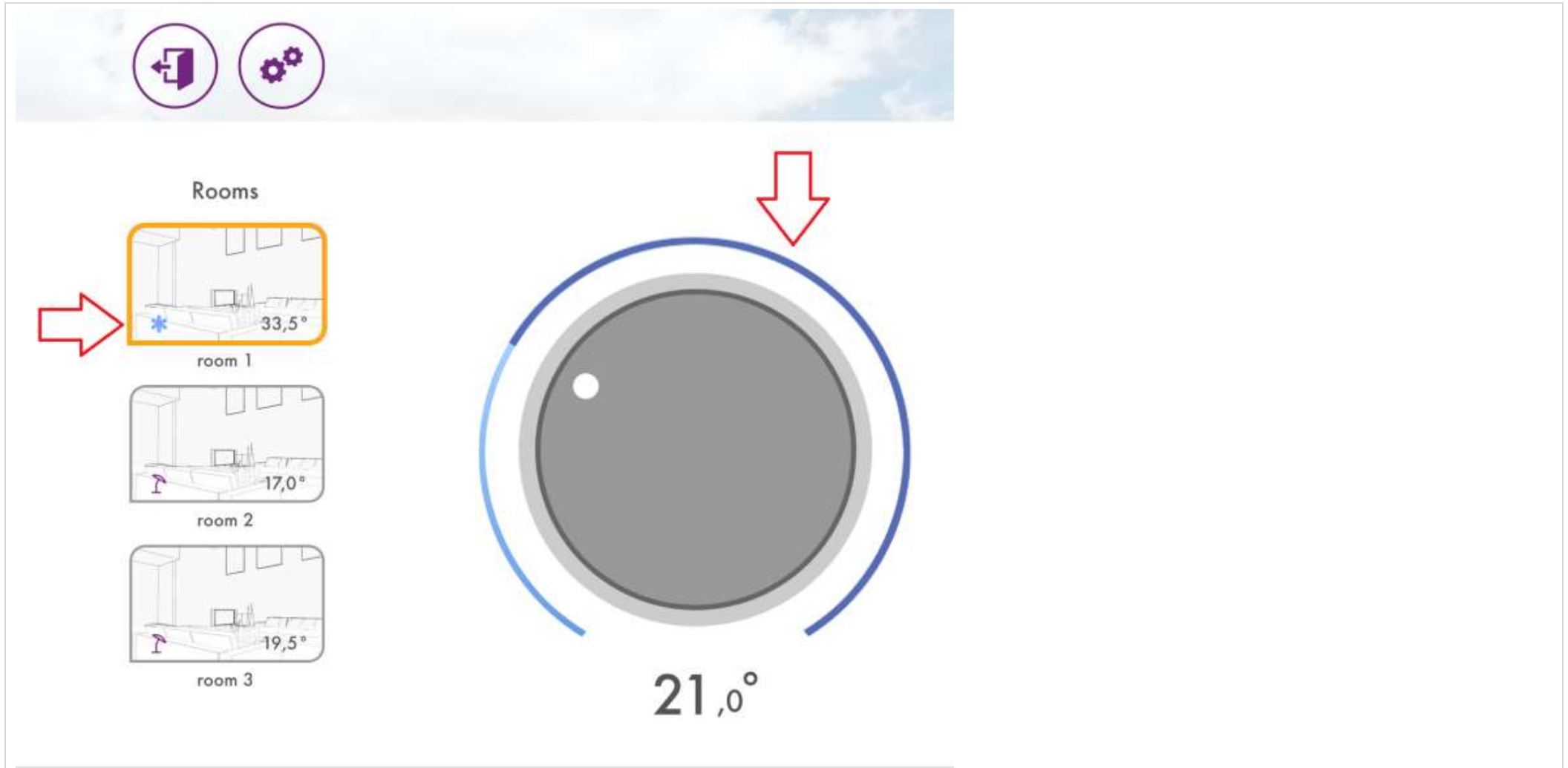

Fig. 42: Display Cooling App

If the “rooms” button is selected in the app, the user can activate or deactivate the global cooling function for all rooms. To do so, the bottom right “ice crystal” field must first be tapped to activate the “global cool function”. This option is also available in the menu expert – system – cooling mode.

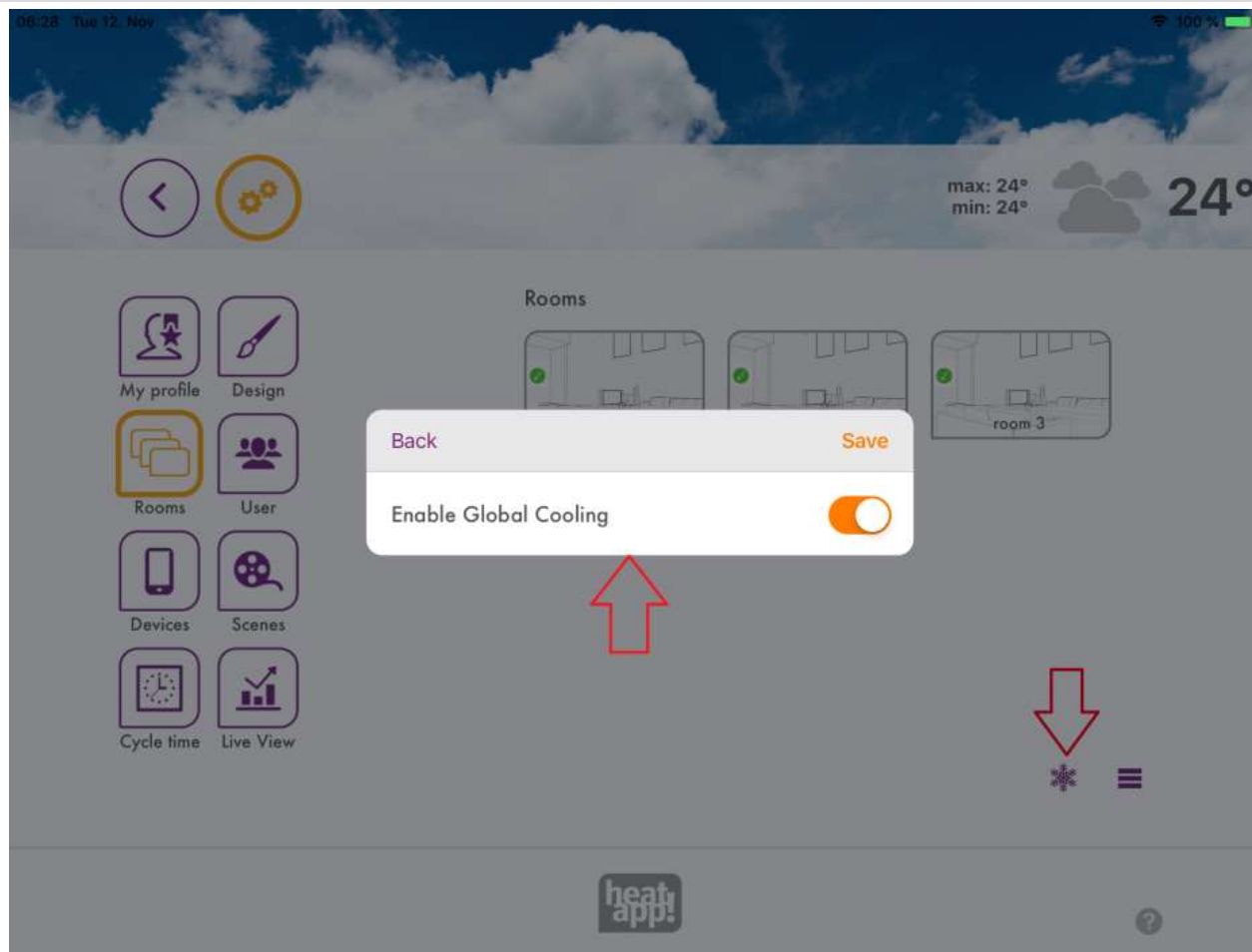





Fig. 43: Activate Cooling App

### 9.4.15 Manual cooling

The heatcon! system offers the possibility to cool rooms independent of the energy source. If cooling energy is available, e.g. by means of an external cooling unit, "manual room cooling" can be activated in the system to enable cooling.

Cooling can only be done in connection with a heatapp! floor system. The cooling can be activated or deactivated for each room.

If there is a cooling demand and active cooling, the system opens the floor channels of the rooms for which cooling has been activated. During manual cooling all heating requirements are blocked and will only be operated again when manual cooling is deactivated. The system opens the floor channels for cooling (only in the rooms selected for cooling) in the operation mode Automatic Day (comfort  and economy  temperature) and Party . No cooling takes place during setback periods or frost protection phases and in standby mode .

## NOTE

---

The cooling function of the heatapp! system is only available to the expert and owner role. An operation with user role is not possible.

---

### 9.4.16 Operating manual room cooling

To enable room cooling, manual room cooling must first be activated in the System menu tree in the Expert menu. Switching from heating to cooling or conversely can be done both in the app and in the Expert menu.

#### Expert menu

Menu	Parameter	Description
Expert / System	Manual room cooling	<b>Off</b> On: Enables or disables the cooling function for the system
	Cooling mode	Off : Cooling function deactivated for all rooms <b>On:</b> Cooling function activated for all rooms for which cooling has been enabled.
Expert / Room	Cooling mode / cooling release	<b>Off:</b> Cooling deactivated for this room On: Cooling activated for this room
	Room thermostat	Off: Cooling is not switched off above Setpoint temperature < actual temperature. <b>0.1 K ... 5.0 K:</b> Setting of the point at which the system stops cooling when the room temperature falls below the Setpoint temperature.

By selecting the system parameter "Manual room cooling" to "ON", the other parameters of the cooling function are enabled. With the cooling mode parameter in the system, cooling can be activated (no heating mode possible) and deactivated (no cooling mode possible) = switchover between heating and cooling.

For each room with heatapp! floor channel the parameter cooling mode is available to enable or disable the cooling release. The room thermostat value is used to determine the point at which the floor valve of this room closes when the room temperature falls below the Setpoint temperature.

Rooms,









- that are not to be cooled can be recognised in the room information by the status room shutdown.
- that are to be cooled are indicated in the room information by the status Cooling.

## heatapp! App

With activation of "Manual room cooling" in the menu Expert the snowflake symbol ❄️ is available in the heatapp! app under setting rooms. By touching it the dialogue window "Global cooling function" opens for activation or deactivation of the cooling. By tapping on "Save" the setting is accepted, by tapping on "Back" the window closes without accepting the changes.

By tapping the rooms, the "Cooling function" switch can be used to activate or deactivate cooling for the respective room.

### Display of the symbols in the room images when the global cooling function is activated:

Symbol	Cooling function switched on in the room	Status of the floor channel	Description
	Yes	On	Automatic daytime operation mode (comfort or economy temperature) Room cooling active Set temperature < Current temperature
	Yes	Off	Automatic daytime operation mode (comfort or economy temperature) Room cooling not active Set temperature > Current temperature
	Yes	On	Operation mode Party Room cooling active Set temperature < Current temperature
	Yes	On	Desired temperature < Current temperature by adjusting the rotary wheel Room cooling active
	Yes	Off	Desired temperature > Current temperature by adjustment on the rotary wheel Room cooling not active, heating Request blocked
	Yes	Off	Operation mode set-back temperature, standby or go Room cooling blocked Set temperature < Current temperature
	No	Off	Room cooling deactivated Independent of set and actual temperature
	No	Not available	No floor channel assigned in the room, room cannot be cooled. Independent of set and actual temperature

## 9.5 Room groups and rooms

Menu	Parameter	Description
Expert / Room (group) / Basic settings	Request	<p>Selection of the requirement for the room/room group.</p> <ul style="list-style-type: none"> <li>– <i>Outside temperature control:</i> Weather guided by outside temperature measurement and Setpoint determination via the heating curve. Depending on the room factor, the Setpoint-actual value comparison of the room temperature is incorporated in the calculation of the required heating circuit Setpoint.</li> <li>– <i>Room control:</i> With room control via Setpoint-actual comparison of the room temperature and determination of the heating circuit Setpoint via a PI control algorithm. This is purely a room control mechanism without any weather influence.</li> <li>– <i>Constant control:</i> The control takes place at a constant flow temperature and is independent of room control and outside temperature control.</li> </ul>

### NOTE

---

If "Constant control" is selected, the App displays the current temperature of the heating circuit in the room picture / room group picture.

---

The *heatcon!* system deviates between room groups and rooms.

- *Room group:*  
A room group is created for each heating circuit. This can comprises several rooms. The settings apply to all rooms of the room group that are supplied by one heating circuit.
- *Room:*  
A single room refers to individual rooms where the regulation is carried out via a single room heat regulation system.

All functions described in this chapter are available for each room group or room and can accordingly be set separately.

### 9.5.1 Room temperatures

Parameter	Setting range	Description
Expert / Room 1... 24 / <b>Room settings</b>		
Expert / Room group 1 ... n / <b>Room settings</b>		
Comfort temperature	Economy temperature ... <b>21.0</b> ... 28.0 °C	Room Setpoint temperature, which is required in the usual way during the programmed switching time.
Economy temperature	Set-back temperature ... <b>20.0 °C</b> ... Comfort temperature	Reduced room Setpoint temperature, which is required in the usual way during the programmed switching time.
Set-back temperature	Frost protection temperature ... <b>18.0 °C</b> ... Economy temperature	Room target temperature, used for regulation outside the programmed switching times if set-back mode is active.
Frost protection temperature	4.0 ... <b>16.0 °C</b> ... Set-back temperature	<p>Independent of the outside temperature-frost protection, the frost protection temperature in the room settings defines the room frost protection.</p> <p>The setting is effective in the following Operation modes.</p> <ul style="list-style-type: none"> <li>– During Vacation mode</li> <li>– During STANDBY operation</li> <li>– In automatic mode between the heating cycles with active standby function</li> <li>– In constant reduce mode (set-back mode)with active standby function</li> </ul> <p>In connection with a room temperature sensor, during this period the room is controlled according to the room frost protection temperature.</p> <p>Without a room temperature sensor the setting serves as a default value for the reduced room temperature and is used for heating circuit flow temperature calculation.</p>
Boost offset	0.5 ... <b>2.0</b> ... 5.0 K	If the boost scene is activated (only possible via <i>heatapp! APP</i> ), current room Setpoint is increased by the set value. The time setting is made via the <i>heatapp! APP</i> .

All temperature values can be defined individually for each room/room group.

#### NOTE

When continuous frost protection mode is applied and there are sensitive objects in the house such as antiques, plants, etc., the setting of the *frost protection temperature* must be adjusted accordingly.

## 9.5.2 Room temperature control

Menu	Parameter	Description
... / Room (group) / Heating mode	Regulation gain	Gain setting of the PI controller for room control.
	Regulation adjust time	Integral action time setting of the PI controller for room control.
	Regulation scan time	Sample time setting of the PI controller for the solar circuit room control.

Each room or room group can be controlled via a room control. To do so, the actual temperature must be measured with a room sensor.

The room control directly determines the required flow Setpoint and transfers it to the corresponding heating circuit. The heat requirement is determined from the room temperature difference (room Setpoint to room-actual).

Control of the room temperature in the *heatcon!* system takes place via an integrated PI controller. The following parameters influence the behaviour of the control function. The individual parameters are described in detail in this chapter.

### Requirement Setpoint (PI controller)

To generate a heating requirement, the control deviation ( $\Delta x$ ) is used, the latter is the temperature difference between the room actual value and the room Setpoint. From this control deviation, the temperature requirement is determined by consideration of the control parameters gain, integral action time and sample time.

#### Example:

With a room actual temperature of 18 °C and a room Setpoint temperature of 20 °C the control deviation  $\Delta x$  is 2 K.

### Regulation gain

The gain factor K defines the correcting variable change to the heating circuit requirement dependent on the control deviation. The control range  $X_p$  is limited by the correcting variable limits (minimum and/or maximum temperatures). If there is a sudden change in the Setpoint, the heat requirement tracking takes place according to the selected setting.

If there is a Setpoint change (day, night or correction), the controller is initialised and starts directly with a correcting variable change, which is derived from the current control deviation.

#### Example:

If there is a control deviation of 2 K (e.g. changeover from reduce to daytime operation) and a gain of 8, the heating circuit requirement changes by 16 K (2 K x 8).



### Regulation adjust time

The integral action time defines the dynamics that the controller requires for an open control loop, to again apply the same amount from the Setpoint jump. The integral action time is constant, independent of the size of the deviation.

The integral action time must be determined based on the reaction behaviour of the heating system (underfloor heating system, radiators, etc.) in response to the room temperature change.

#### Example:

If there is a control deviation of 2 K and a gain of 8, there is a correcting variable change  $y_0 = 16$  K.

With open controller operation a further application of the same amount (16 K) takes place inside the set integral action time (15 minutes).

With a minimum temperature of 20 °C, after 15 minutes the controller reaches a Request value of 52 °C ( $y_{min} + y_0 + y_{t15}$ ).

### Regulation scan time

The sample time is a controller-internal quantity that defines the time interval between two sequential actuator pulses when a deviation is detected.

In the room control, the sample time is pre-set to 20 minutes.

## 9.5.3 Weather-guided heating operation (outside temperature control)

### 9.5.3.1 Heating curve

Menu	Parameter	Description
Expert/System	Clima zone	Setting of the coldest anticipated outside temperature value (design temperature).
Expert / Room (group) / heating mode	Heating curve	Steepness setting of the heating curve with outside temperature control.
	Heating system	Exponent setting or m-value. <ul style="list-style-type: none"><li>– Underfloor heating system: 1.10</li><li>– Radiator: 1.30</li><li>– Convector: 1.40</li><li>– Ventilation: &gt;2.00</li></ul>
	Room factor	Room factor setting (room temperature influence).

The prerequisite for a constant room temperature is the exact setting of the heating curve of the relevant room or room group (heating circuit) as well as a correct design of the heating system on the part of the heating specialist according to the heat demand calculation.

If adjustment of the heating curve is necessary, it should be made in small steps at intervals of a few hours to assure that a steady state condition has been set.

Differences that can be balanced by installing a room device (*heatapp! drive* or *heatapp! sense*) may occur between the measured room temperature in the inhabited area and the desired room temperature.

The gradient of the heating curve describes in general the relationship between the change in the flow temperature and the change in the outside temperature. With large heating surfaces such as underfloor heating systems, the heating curve is less steep than that of smaller heating surfaces such as radiators.

The setting refers to the lowest outside temperature used for heat demand calculation.

If the heating curve is correctly set, the room temperature remains constant according to the set daytime Setpoint irrespective of changes in the outside temperature.

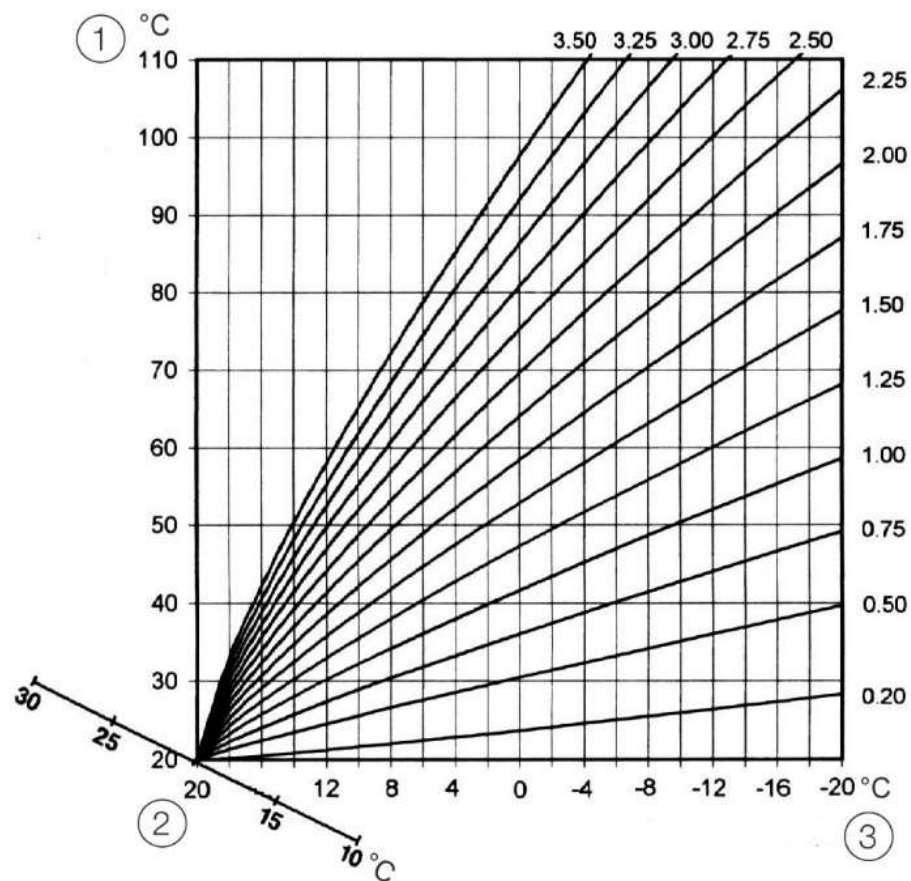

Fig. 44: Heating Characteristic Curve

1 Flow temperature  
2 Room temperature

3 Outside temperature

## NOTE

---

The heating curve is valid within the minimum and maximum temperature limits for the heating circuit in question. With activated limits the relevant flow temperature is controlled exclusively according to the set limit values.

---

### 9.5.3.2 Room factor:

The room factor setting range is: OFF, 10 ... 500%

This function determines to what extent a deviation of the room temperature from the Setpoint affects control of the flow temperature.

If there is no difference between the desired (NOM) and the current (ACT) room temperature, the direct heating circuit's flow temperature is controlled according to the set heating characteristic.

If there is a difference between the room temperature and the Setpoint, the heating characteristic is shifted parallel to the room temperature axis so that the deviation is compensated. The amount of the displacement depends on the setting of the room factor.

The following equation applies:

$$\text{Corrected room target value} = \text{set room target value} - (\text{deviation K} * \text{room factor}) / 100$$

Examples:

Defined Setpoint = 21°C

Actual Setpoint = 20°C

Deviation = -1K

With the room influence equal to 100%, this yields:

$$\text{Corrected Setpoint} = 21^\circ\text{C} - (-1\text{K} * 100) / 100 = 22^\circ\text{C}$$

The boiler temperature is controlled according to a heating characteristic which corresponds to a room temperature Setpoint of 22 °C.

With the room influence equal to 500%, this yields:

$$\text{Corrected Setpoint} = 21^\circ\text{C} - (-1\text{K} * 500) / 100 = 26^\circ\text{C}$$

The boiler temperature is controlled according to a heating characteristic which corresponds to a room temperature Setpoint of 26°C.

High settings lead to a quicker adjustment of the control deviation, while they reduce the stability of the control circuit and can lead with excessively high Setpoints to the oscillating of the control value (= room temperature).

### 9.5.3.3 Summeroperation mode / summer shut down

Menu	Parameter	Description
Expert / Room (group) / Basic settings	Summer operation mode	Outside temperature setting for activation of summer Operation mode for the room/room group.

The *summer shutdown* function cOffes heating operation to be switched off for outside temperatures above the set *summer Operation mode* temperature.

- **Summer operation mode activation:**  
Summer operation mode is activated, if the outside temperature exceeds the summer Operation mode Setpoint.  
If sensors OS1 and OS2 are assigned to a room, then the corresponding values of the two sensors are used to determine the summer shutdown.
- **Deactivation of summer Operation mode:**  
Summer operation mode is deactivated if the long term outside temperature falls below the Setpoint by 1 K.  
If sensors OS1 and OS2 are assigned to a room, then the corresponding long term values of the two sensors are used to determine the summer shutdown.

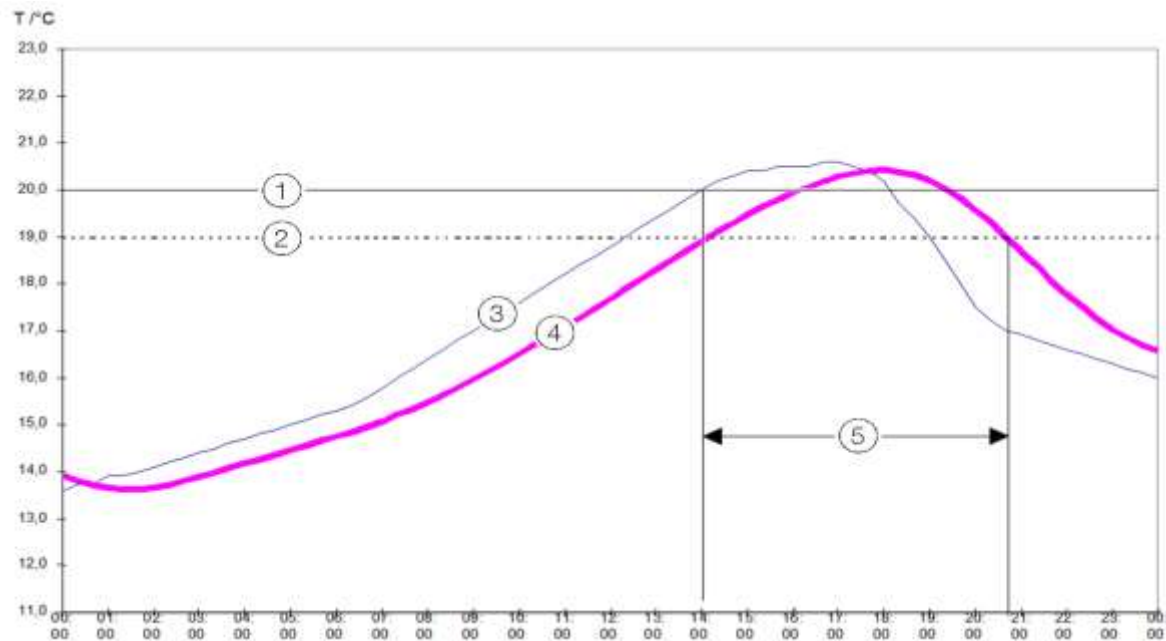

Fig. 45: Summer operation

1	Setpoint, "summer soperation" parameter	4	Long term outside temperature
2	Hysteresis -1 K	5	Summer shutdown active
3	Actual outside temperature		

## NOTE

Summer operation is overridden in the following cases:

- If an outside sensor is defective
- If the frost protection function is activated (see section "Frost protection function", on page 143)

### 9.5.3.4 Heat limit

Menu	Parameter	Description
Expert / Room (group) / heating mode	Heat limit	Heat limit setting for the room.

The *Heat limit* function can be activated separately for each room. The heat limit function causes the corresponding Request to the room/room group to be switched off as soon as the calculated flow Setpoint temperature falls within the range of the room Setpoint temperature.

#### Function description:

- Shutdown of the heating circuit:  
Flow Setpoint temperature < (Room Setpoint temperature + heat limit offset)
- Switch on of the heating circuit:  
Flow Setpoint temperature > (Room Setpoint temperature + heat limit offset + 2 K)
- The *Summer shutdown* function takes priority over the *Heat limit* function
- The function *System frost protection* takes priority over the *Heat limit* function during shutdown in constant reduced mode with activated ECO function.

### 9.5.4 Switch on optimisation

Menu	Parameter	Description
Expert / Room (group) / heating mode	Switch on optimisation	Start time advance setting dependent on the outside temperature.

With this function the latest heating up time is calculated taking into consideration the outside temperature (heat loss) to ensure the desired room temperature at the set occupancy start time. The switch-on times saved in the timer programs for the relevant room no longer refer to the heating start time but to the occupancy start time (i.e. the time at which the desired room temperature is reached).

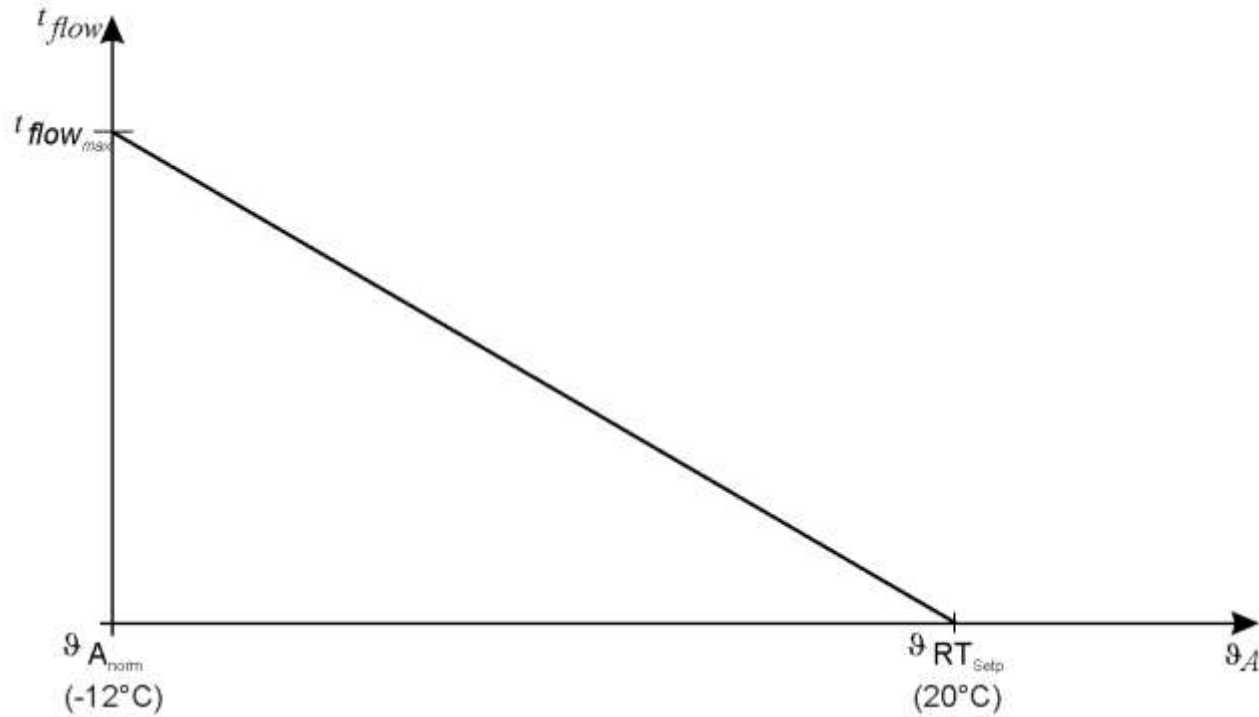

Fig. 46: Calculation of the advanced switch-on time

$$t_{flow} = t_{flow_{max}} \times \left( 1 + \frac{\vartheta_{Norm}}{\vartheta_{RTSetp} - \vartheta_{Anorm}} - \frac{\vartheta_A}{\vartheta_{RTSetp} - \vartheta_{Anorm}} \right)$$

$$t_{flow} = t_{flow_{max}} \times \left( 1 + \frac{\vartheta_{RTSetp} - \vartheta_A}{\vartheta_{RTSetp} - \vartheta_{Anorm}} \right)$$

$\vartheta_{RTset}$	=	Room Setpoint temperature at the start time (adjusted switch on time)
$t_{adv_{max}}$	=	Maximum advanced switch-on time ( <i>Start optimisation</i> parameter)
$\vartheta_{DStd}$	=	Standard design temperature ( <i>climate zone</i> parameter)
$t_{adv}$	=	= Actual advanced switch-on time
$\vartheta_o$	=	Outside temperature

### 9.5.5 Screed drying function

Menu	Parameter	Description
Expert / Room (groups)	Screed	Selection of the screed function.

The screed function is used exclusively for the prescribed drying of newly created screed for underfloor heating systems. The recommendation of the Bundesverband Flächenheizungen (Federal Association of Underfloor Heating) for heating according to the prescribed temperature profile is used as a basis.

The screed function is a special function and is not interrupted by any other operation mode (not even manual mode or emission measurement)!

After activating the screed function, all weather-compensated control functions of the corresponding room are switched off. The corresponding room operates as a constant temperature controller regardless of the operation mode (cycle times).

An activated screed function is shown in the basic display of the MMI. Here, the duration and the currently executed day are additionally displayed, so it is recognizable on which day the screed function is located (screed n/n). In the event of a power failure during an active screed function, the timer of the screed function is started with the day on which the power failure occurred after the function is switched on again. It is thus possible that the screed function is extended by a maximum of one day.

A screed function that has already been switched on can be deactivated at any time.

The expiration of a screed day is based on a 24h timer.

After the screed function is terminated, the room operates again according to the currently set operation mode.

#### ATTENTION

##### **Screed damage resulting from over-fast drying of the screed!**

Prior to activation of the screed function it must be ensured that the screed is dry enough.

- Cement screed: 21 days
- Calcium sulphate (anhydride) screed: 7 days

The drying is not necessarily completed once the drying program is completed, rather it should be checked by measuring the moisture level.

##### **Setting: Functional heating according to DIN 4725 Part 4**

- Screed function for a duration of 8 days
- When the screed function "Functional heating" is activated, heating is constant at 25 °C for the first four days.
- Then for the next four days at the set maximum flow temperature, but limited to 55 °C.

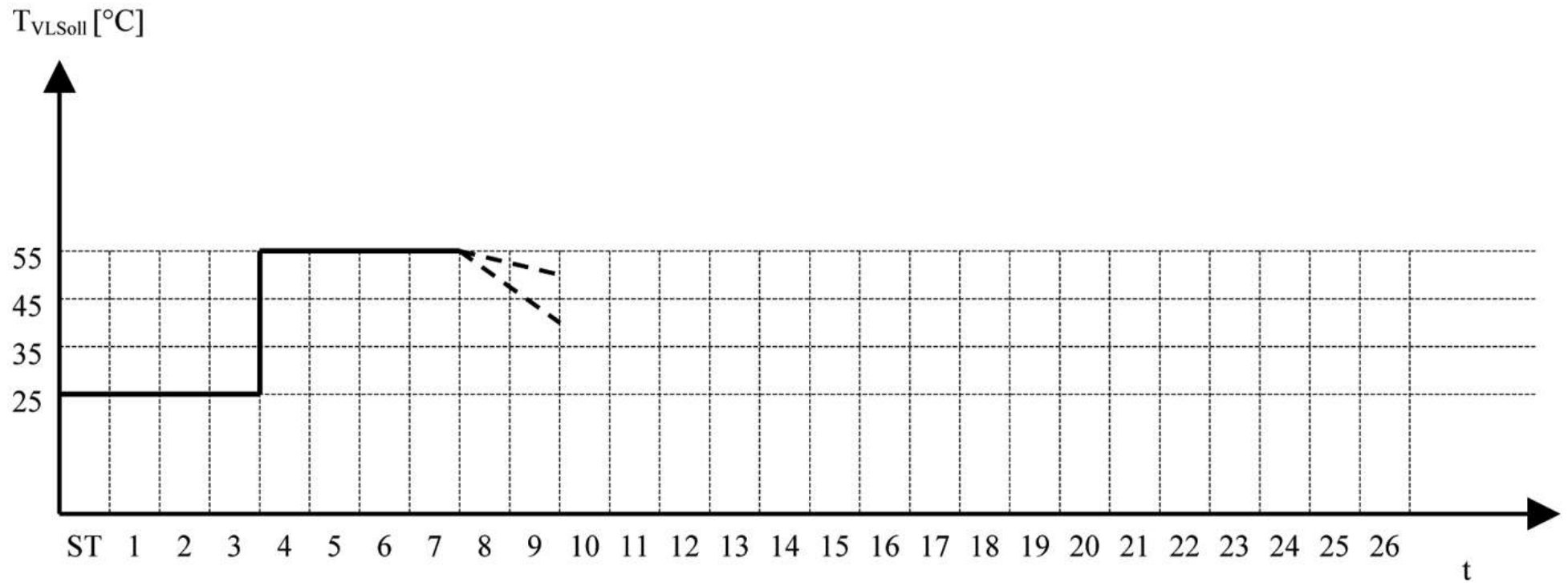

Fig. 47: Time sequence - functional heating

#### Setting: Floor covering - laying heating

Floor covering heating follows a specified temperature Expertle.

Starting at 25 °C on the first day, the Requested temperature rises by 5° per day over the following days until the set maximum temperature of the room is reached.

At the end of the fourth day for the following eleven days the flow temperature of the mixer circuit is regulated to flow maximum temperature (limited, however, to 55 °C!). After this time has elapsed, for the next day (day 16), the flow temperature is regulated to 35 °C.

After that the Setpoint temperature is reduced with the same steps until the base point of 25 °C has been reached again.



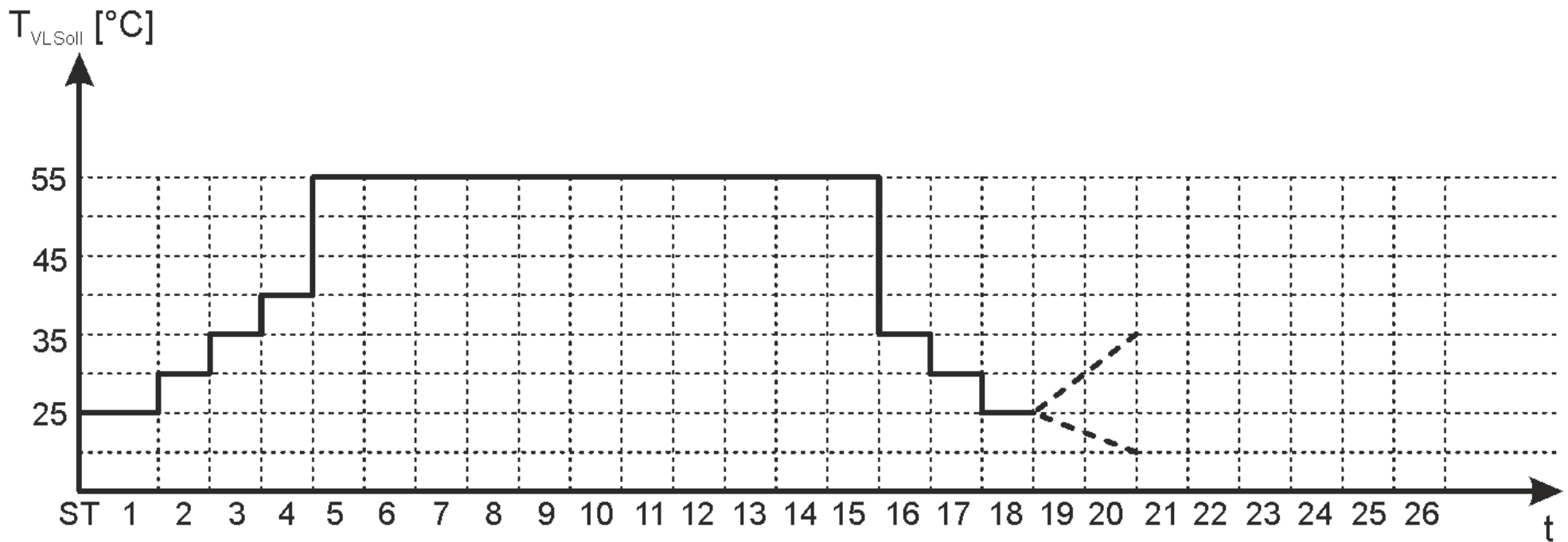

Fig. 48: Time sequence - floor covering heating

Example:	
Maximum temperature setting for the heating circuit: 55 °C	
1. Day:	constant heating at 25 °C
2. Day:	constant heating at 30 °C
3. Day:	constant heating at 35 °C
4. Day:	constant heating at 40 °C
5.-15. Day:	constant heating at maximum flow temperature (limited to a maximum of 55°C)
16. Day:	reduced heating at 35 °C
17. Day:	reduced heating at 30 °C
18. Day:	reduced heating at 25 °C

**Setting: Functional heating with following floor covering heating**

Steps 1 and 2 can also follow each other automatically.

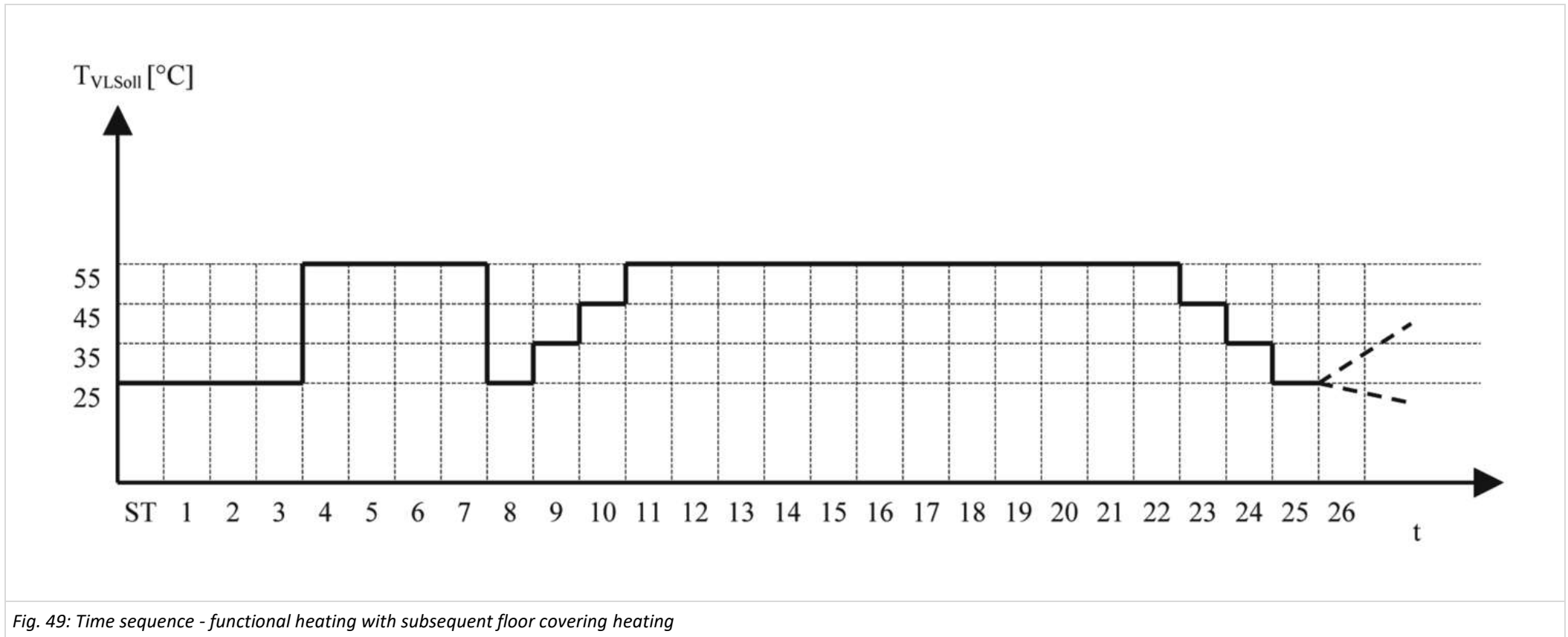

Fig. 49: Time sequence - functional heating with subsequent floor covering heating

The maximum temperature Experte is determined based on the respective maximum flow temperature limit (maximum 55°C).

The Screed function parameter is automatically set to OFF when the function is completed. The screed function can be activated again if necessary.

**Setting: manual**

30 days are available for the individual screed program. The adjustable temperature range extends from OFF, 15°C to 65°C.

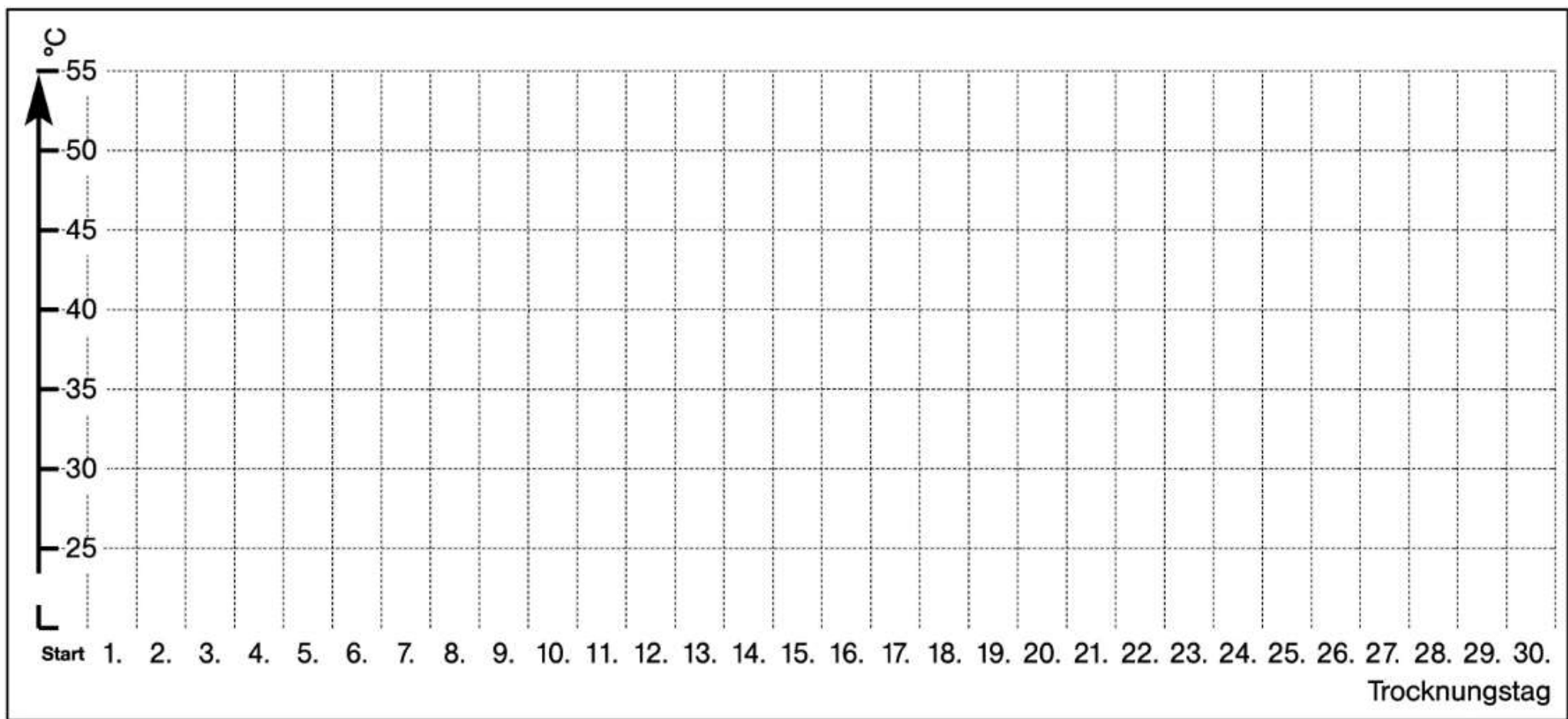

Fig. 50: Time sequence Manual setting Screed Function

Expert / Room 1... 24 / <b>Basic settings</b>			
Expert / Room group 1 ... n / <b>Basic settings</b>			
Screed	<b>Off</b> , functional heating, laying heating, functional and laying heating, manual	Selection of the screed heating program for the room/room group.	HF

The individual screed program is activated if the parameter in “room/room group – basic settings - screed” is set to “manual”. Then a further menu “screed” is enabled which makes it possible to assign a custom screeding temperature “temperature day n” (n = 1-30) for up to 30 days. The custom flow Setpoint value can be entered here for days 1 to 30. Once a value has been entered

here, the setting for the next day can be made. If “Off” is entered for one day, the screed program ends at the end of the day with the last entered Setpoint. Once the screed program is ended, the heating circuit is placed in “STANDBY” (flow Setpoint = 0, HCP = OFF, mixing valve = CLOSED).

Day	Flow set point constant (°C)	Day	Flow set point constant (°C)
Temperature day 1	Off, 15 ... 65°C	Temperature day 16	Off, 15 ... 65°C
Temperature day 2	Off, 15 ... 65°C	Temperature day 17	Off, 15 ... 65°C
Temperature day 3	Off, 15 ... 65°C	Temperature day 18	Off, 15 ... 65°C
Temperature day 4	Off, 15 ... 65°C	Temperature day 19	Off, 15 ... 65°C
Temperature day 5	Off, 15 ... 65°C	Temperature day 20	Off, 15 ... 65°C
Temperature day 6	Off, 15 ... 65°C	Temperature day 21	Off, 15 ... 65°C
Temperature day 7	Off, 15 ... 65°C	Temperature day 22	Off, 15 ... 65°C
Temperature day 8	Off, 15 ... 65°C	Temperature day 23	Off, 15 ... 65°C
Temperature day 9	Off, 15 ... 65°C	Temperature day 24	Off, 15 ... 65°C
Temperature day 10	Off, 15 ... 65°C	Temperature day 25	Off, 15 ... 65°C
Temperature day 11	Off, 15 ... 65°C	Temperature day 26	Off, 15 ... 65°C
Temperature day 12	Off, 15 ... 65°C	Temperature day 27	Off, 15 ... 65°C
Temperature day 13	Off, 15 ... 65°C	Temperature day 28	Off, 15 ... 65°C
Temperature day 14	Off, 15 ... 65°C	Temperature day 29	Off, 15 ... 65°C
Temperature day 15	Off, 15 ... 65°C	Temperature day 30	Off, 15 ... 65°C

### 9.5.6 Room blocking

Menu	Parameter	Description
Expert / Room (group) / Basic settings	Room blocking	Outside temperature setting for activation of room blocking for the room/room group.

The function *Room blocking* defines the temperature in the, from which the heating requirement for this room or room group is switched off. Room blocking is active both during room control and also during weather control.

#### Function description:

- *Shutdown of the room/room group:*  
Room actual temperature > (Room Setpoint temperature + room blocking)

## 9.6 Domestic hot water-functions

Hot water temperature control can be performed in two ways.

### Temperature control via storage sensor (KTY/Pt100)

The storage sensor is connected to the input for the storage temperature sensor (DHWS). The *heatcon!* system measures the DHW temperature via the storage sensor and activates the corresponding function (DHW charging, etc.) according to the set Setpoints and timer programs.

### Temperature control via thermostat (switch contact On/Off)

The external thermostat of the DHW storage is connected using a switch contact to the input for the DHW storage sensor (DHWS). Setpoint setting for the DHW temperature is performed by adjusting the thermostat.

If the thermostat Requests energy via the storage sensor input (contact closed), the storage is charged with hot water at the set hot water maximum temperature until the contact opens again.

#### NOTE

---

If temperature control is via a thermostat, the hot water Setpoint temperature cannot be set via the *heatcon!* system. Also the actual hot water temperature is not displayed via *heatcon! MMI*, the *heatapp! App* or the PC user interface of *heatcon! EC*.

---

### 9.6.1 Hot water control via the storage sensor

The following parameters influence the behaviour of the control function. The individual parameters are described in detail in this chapter.

Menu	Parameter	Description
Expert / Domestic hot water / Heating mode	Day Setpoint	Setting of the hot water Setpoint temperature for heating operation.
	Night Setpoint	Setting of the hot water Setpoint temperature for reduce mode.
	Discharge protection	Activation of the discharge protection function.
	Increase of Request	Raising setting for forwarding the requirement to the energy source.
	Switching difference	Switching difference setting for hot water storage charging
	Hysteresis	Hysteresis setting for hot water storage charging.
Expert / Configuration / function / Domestic hot water	DHW storage sensor 2	Assignment DHW storage sensor 2 (bottom) for stratified discharge.

### **Day Setpoint**

Hot water Setpoint temperature for daytime operation. The day Setpoint is limited by the maximum temperature.

### **Night Setpoint**

Setting of the hot water Setpoint temperature in setback operation. The setting is between 5°C and day Setpoint.

The hot water is fixed at 5°C. If the DHW storage temperature falls below this fixed DHW minimum temperature of 5°C (frost protection temperature), the storage is charged once at 8°C. If the switching difference is greater than 3 K, then the DHW storage is charged to 5 °C + switching on hysteresis.

### **Discharge protection**

The discharge protection function is to prevent the discharging of the DHW storage via the heating circuit.

If discharge protection is activated and the temperature of the energy generator is less than the actual temperature of the DHW + 2 K, then DHW charging is blocked.

As soon as the temperature of the energy generator has exceeded the actual temperature of the DHW by 5 K, DHW charging is enabled.

If the temperature of the energy generator subsequently falls below the actual DHW temperature + 2 K, DHW charging remains enabled.

If storage discharge protection is deactivated, DHW charging is enabled immediately when a corresponding Request exists.

### **Increase of Request**

The DHW Setpoint plus a Request increase is transferred to the energy generator as a Request. Hence possible energy losses are compensated and the DHW charging ends more quickly so that because of the DHW priority mode, the heating circuits can be enabled more quickly.

---

### **NOTE**

---

If a sensor is faulty (short circuit, open circuit), DHW charging is blocked again, or is not enabled.

---

### **Switching difference**

Switch on difference for switching on of DHW charging.

If the actual DHW temperature falls below the DHW Setpoint temperature (day Setpoint/night Setpoint) by the value set here, hot water charging is activated and a Request is submitted to the energy management.

The DHW storage charging Pump is switched on dependent on start protection and storage discharge protection.

### **Hysteresis**

Hysteresis setting for switching off DHW charging.

If the actual DHW temperature exceed the switch-on point (DHW Setpoint temperature + switching difference + hysteresis) the Request to energy management is retracted.

The DHW storage charging Pump remains switched on for the set overrun time.

## DHW storage sensor 2

The DHW storage can optionally be equipped with a second storage sensor (DHWS2), which is used for storage stratified charging.

If the second storage sensor is used, storage charging starts via the active energy generator as soon as the highest temperature (of both sensors) falls below the specified Setpoint.

Charging is finished if the lowest of both temperatures exceeds the Setpoint plus the specified hysteresis.

### 9.6.2 Hot water control via an external thermostat

Menu	Parameter	Description
Expert/ Configuration / Hardware / Input	Storage sensor input	Input type for the storage sensor input. Selection <i>Digital OFF/ON</i> for the thermostat.

If DHW storage thermostat operation is configured, the charging Pump is enabled dependent on the Request in accordance with the switching time and the actual operating state of the thermostat transmitted via the storage sensor input.

#### Function description:

- The DHW charging Pump switches on if the input is closed.
- The DHW charging Pump switches off with an open input delayed by the Pump overrun time.

#### NOTE

---

If temperature control is via a thermostat, the hot water Setpoint temperature cannot be set via the *heatcon!* system. Also the actual hot water temperature is not displayed via *heatcon! MMI*, the *heatapp! App* or the PC user interface of *heatcon! EC*.

---

### 9.6.3 Hot water operation

Menu	Parameter	Description
Expert / Domestic hot water / Basic settings	Operation mode	Selection of the operation mode for hot water heating.

The hydraulic conditions and the hot water use require different hot water modes in order to fulfil the requirements.

#### Parallel Operation mode

In *Parallel* Operation mode, DHW storage charging takes place in parallel to the heating circuit function.

It is recommended that this Operation mode is only used in conjunction with mixed heating circuits, as direct heating circuits transport the increased flow temperature that exists during hot water charging without control into the heating system. The result can be long hot water charging phases and also overheating of the connected living spaces.



### Priority Operation mode

In *Priority* Operation mode, the heating circuits are blocked during hot water charging and only released again once the hot water charging has ended its Pump overrun time.

This ensure faster hot water charging, becOffe the energy of the energy generator is not withdrawn by the heating circuits.

If hot water is frequently drawn off, the consequence are frequent hot water Requests that must be serviced and consequently, becOffe of a lack of operation of the heating circuits, possible cooling of the living area.

### Conditional priority Operation mode

In the *conditional priority* Operation mode, the release of the mixed heating circuits takes place when the energy generator temperature has exceeded the DHW storage Setpoint temperature + hot water Switch-off difference + 10K.

Direct heating circuits remain in priority mode.

This Operation mode should ensure that hot water charging takes priority and only if the energy generator temperature is sufficient are the mixed heating circuits switched to parallel mode.

### Operation mode, Weather conducted parallel operation

Menu	Parameter	Description
Expert / Domestic hot water / Basic settings	Frost protection	<p>Setting of the frost protection limit for the Operation mode <i>Weather conducted parallel operation</i>.</p> <ul style="list-style-type: none"><li>• Above the outside temperature set here, hot water charging takes place in priority mode; if the temperature falls below the outside temperature set here, a changeover to parallel mode takes place.</li><li>• The changeover back to priority mode occurs when the temperature falls below the set temperature by 1 K.</li></ul>

In the Operation mode, *weather conducted parallel operation*, the hot water control operates in priority mode above the set frost protection limit.

As soon as the outside temperature falls below the set frost protection temperature, hot water charging takes place in parallel mode. Switching back to priority mode occurs when the outside temperature has exceeded the frost protection temperature by 1 K.

Here hot water charging should have priority, however, to prevent cooling of the rooms resulting from the outside temperature, it is possible to switch over to parallel mode.

### Operation mode, Priority with interval heating

In the Priority with intermediate heating operation mode, a hot water charging process may last a maximum of 20 minutes.

If this time is exceeded, the switchover to intermediate heating of the heating circuits takes place for 10 minutes, while maintaining the set overrun of the storage tank charging Pump. Only after the intermediate heating has elapsed, the hot water charging becomes active again.

Note: The operation mode Priority with intermediate heating is recommended above all for unmixed heating circuits, since heating circuits with mixers cannot open the mixing valve to the required extent during the time of intermediate heating.

## NOTE

The operation mode Priority with intermediate heating is recommended above all for unmixed heating circuits, as heating circuits with mixers cannot open the mixing valve to the required extent during the time of intermediate heating.

### 9.6.4 Legionella protection function

#### CAUTION

##### Risk of scalding!

Risk of scalding with the Legionella protection function activated because of heating of the hot water above 60°C.

- Only qualified personnel may activate the Legionella protection function.
- Inform the users of the hot water system of the risk of scalding during the period of the Legionella protection function.
- When using hot water taps, mix in sufficient cold water.

Menu	Parameter	Description
... / Domestic hot water / Heating mode	Legionella protection day	Selection of the day for legionella protection.
	Legionella protection time	Time setting for legionella protection.
	Legionella protection -temperature	Temperature setting for legionella protection.
	Legionella protection charging duration	Charging duration setting for legionella protection.

The legionella protection function can be activated to eliminate legionella germs in the storage.

In order to completely kill all germs, the legionella protection temperature should be set to at least 60 ... 65 °C.

### 9.6.5 Shutdown type

Menu	Parameter	Description
<i>Expert/DHW /Basic settings</i>	Shutdown	Selection of the type of shutdown for hot water heating. <ul style="list-style-type: none"><li>• <i>Room:</i> If all rooms are in Vacation and/or standby mode, then hot water heating is also automatically placed in standby mode.</li><li>• <i>Operation mode:</i> The changing of the hot water heating Operation mode is dependent on the Operation mode set on the <i>heatcon!</i> controller.</li></ul>

The hot water heating shutdown can be coupled to the shutdown of the rooms via the *Shutdown* parameter.

### 9.6.6 Hot water charging via Heating usage

Menu	Parameter	Description
... / Configuration / function / Domestic hot water	Function	Activation of hot water charging using a Heating usage. <ul style="list-style-type: none"> <li>• <i>Heating usage</i>: Heating usage activated.</li> </ul>
	Flow sensor	Sensor input assignment for Heating usage flow sensor.
... / Domestic hot water / Heating usage	Summer operation mode	Activation of the Heating usage based on the set outside temperature.
	Setpoint raise	Setting for matching the hot water Setpoint with an active Heating usage. <ul style="list-style-type: none"> <li>– <i>ON</i>: Outside temperature &gt; “<i>Summer operation mode</i>” Temperature</li> <li>– <i>OFF</i>: Outside temperature &lt; “<i>Summer operation mode</i>” Temperature – 1K</li> </ul>

During the summer, the function enables an alternative hot water charging operation using an electric Heating usage in the DHW storage.

For this purpose, hot water charging via the Heating usage must be configured.

#### Operation release

In no sensor has been assigned to the function, release takes place dependent on the active Operation mode:

- *ON*: Automatic in heating mode, heating, party
- *OFF*: Automatic in reduce mode, reduce, standby

#### Operation release with temperature monitoring

In a sensor has been assigned to the function, release also takes place dependent on the latest actual temperature. The parameter *Set point raise* can be used to set an additional set point raise.

- *On*: DHW storage sensor < Hot water Setpoint temperature + Setpoint raise + switching difference
- *Off*: DHW storage sensor > Hot water Setpoint temperature + Setpoint raise + switching difference + hysteresis

## 9.6.7 DHW circulation pump

Menu	Parameter	Description
... / Configuration / function / Domestic hot water	Function	Activation of the circulation pump for the hot water function. <ul style="list-style-type: none"><li>• <i>DHW circulation pump</i>: Circulation Pump activated.</li></ul>
	Assignment sensor 1	Assignment sensor input for sensor 1 (current temperature1) of the circulation pump.
	Assignment sensor 2	Assignment sensor input for sensor 2 (current temperature2) of the circulation pump.
... / Domestic hot water / circulation pump	Mode	Selection of the operation mode for the DHW circulation pump.

Circulation Pump (CIR) function can be both time and temperature controlled or be a combination of the two.

On the other hand, the temperature control can be used either as a thermostat function or a difference function.

Depending on the number of selected sensors, the operation mode (thermostat/difference) is activated automatically.

Basically, the function of the circulation pump is coupled to the cycle times of the hot water circuit. In day mode, party mode and during a recharge, standby is activated.

During this standby, the circulation pump is activated according to the selected operation mode.

### Time control mode

The time control refers to the interval control of the circulation pump. During the hot water day switching cycle, the circulation pump is switched on according to the set period and pause time (run time = period time - pause time). An activated party scene is treated like the day switching cycle.

### Temperature mode thermostat function (1 sensor configured)

A sensor is required for the thermostat function mode. The DHW circulation pump is enabled via an adjustable Setpoint taking into account an adjustable switching difference. If the configured Setpoint is exceeded, the DHW circulation pump is shutdown. If the Setpoint is undershot by a set switching difference, the DHW circulation pump is released.

- *DHW circulation pump switched on:*  
Sensor 1 (CPS) < Setpoint – Switching difference
- *DHW circulation pump switched off:*  
Sensor 1 (CPS) ≥ Setpoint

### Temperature mode difference function (2 sensors configured)

Two sensor are required for the difference function mode. Release of the circulation pump takes place as soon as the set hysteresis between sensors 1 and 2 plus an adjustable switching difference is reached.

Blocking of the circulation pump takes place as soon as the set hysteresis between sensors 1 and 2 is undershot.

- *DHW circulation pump switched on:*  
Sensor 1 / Sensor 2 > hysteresis + switching difference
- *DHW circulation pump switched off:*  
Sensor 1 / Sensor 2 < Hysteresis

As soon as Vacation or standby mode is active, the circulation pump is placed in an idle state and switched off. This occurs irrespective of whether control is time or temperature based. If the Pump has not received any Requests within the last 24 hours, forced switching on occurs for a short period (about 20 seconds) via the Pump kick circuit if the anti-lock system is activated to prevent lock.

---

**NOTE**

---

If the circulating Pump function current temperature controlled, then the Pump is placed at a standstill as soon as a sensor fault occurs and then switched off.

---

**9.6.8 Hot water tank 2**

If a free output is available, it is possible to configure a second hot water tank in the same way as the hot water tank 1. The storage tank sensor is configured in the Hot water configuration menu. There is no fixed assignment, as is done for hot water tank 1.

When using the "Priority" hot water operation mode, hot water tank 1 is prioritized over hot water tank 2.

---

**NOTE for app operation**

---

The basic app operation does not provide for the possibility of operating a second DHW charge. This means that the "Shower" scene or the cycle times refer to hot water 1.

The following applies to hot water 2: A recharge ("Shower" scene) or the cycle times can only be activated or changed in the "Expert" menu or on the MMI.

---

## 9.7 Heating buffer functions

A heating buffer is an energy store that is used to store available energy and then to feed it to a heating circuit or the hot water storage when there is a demand.

A heating buffer can be charged with energy in either an uncontrolled or controlled manner.

For example, uncontrolled heating buffer charging takes place via solar thermal system or a log boiler. Here no prediction can be made about the amount of energy or the time at which it will be available.

In general, controlled heating buffer charging is normally performed using a controllable energy generator (boiler, heat Pump).

The heating buffer receives the Request values from the assigned rooms and/or room groups or the hot water charging. If the heating buffer temperature is not sufficient for the Request, the buffer can perform an active charging process (charging operation) using an assigned energy source.

Highest heating buffer temperature	The term <i>Highest heating buffer temperature</i> refers to the highest temperature measured on all available/configured heating buffer sensors. Defective heating buffer sensors are not taken into account in the temperature determination.
Lowest heating buffer temperature	The term <i>Lowest heating buffer temperature</i> refers to the lowest temperature measured on all available/configured heating buffer sensors. Defective heating buffer sensors are not taken into account in the temperature determination.
Energy source flow temperature	The term <i>Energy source flow temperature</i> refers to a temperature to be used to charge the heating buffer. Depending on the hydraulic characteristics, this temperature may be the flow temperature of one or more energy generators or a common flow. This temperature must not be confused with the heating buffer sensor temperature.
Request value	The <i>Request value</i> is the temperature that the heating buffer Requests from the energy generators. This means the temperature with which the heating buffer is to be charged.
Setpoint	The <i>Setpoint</i> is the temperature which a consumer circuit (heating circuit, hot water) Requests from the heating buffer. This means the temperature which the heating buffer should supply via a discharge.
Energy generator start protection	The <i>Energy generator start protection</i> always acts on the heating buffer charge control. An energy generator start protection system should protect the energy generator. This means the heating buffer adjust the charge during energy generator start protection, so that the energy generator can pass through a critical temperature range quickly and without loading. Charge control takes place at: <ul style="list-style-type: none"> <li>• GEN actual <math>\geq</math> Heating buffer Setpoint + 5K.</li> </ul> Renewed blocking of the charge control after previously release charge control occurs at: <ul style="list-style-type: none"> <li>• GEN actual <math>\leq</math> Heating buffer actual + 2K.</li> </ul>
Buffer start protection:	The <i>buffer start protection</i> should protect the buffer and is reported to the consumer circuits. This is then obliged to prevent buffer discharge. The buffer start protection always acts on the energy consumption.

### 9.7.1 Heating buffer variants and components

The heating buffer function can control the following heating buffer variants and components.

#### Heating buffer with charge control (complete hydraulic implementation)

A heating buffer with charge control has a buffer load Pump (BULP) via which the heating buffer is loaded.

- *Heating buffer discharge:*  
Functionally, the heating buffer with charge control is not involved in discharging. Heating buffer discharge takes place via the consumers connected to the heating buffer (heating circuits/hot water).

See also section"

", on page 224.

### **Heating buffer with discharge control (complete hydraulic implementation)**

A heating buffer with discharge control uses the BULP output, as buffer unload Pump (PE) and/or for actuation of a diverter valve as the buffer discharge valve (PEV), via which the heating buffer is actively discharged.

- *Charging of the heating buffer:*

Functionally, the heating buffer with discharge control is not involved in charging. In general charging of the heating buffer is uncontrolled (solid fuel boiler or solar).

See also section "The switching difference for switching of the output is fixed at 5 K and is independent of the buffer switching difference.

- HBD output "ON": Temperature BS < Buffer Setpoint. The heating buffer is only partially loaded (buffer discharge activated).
- HBD output "OFF": Temperature BS > ( Buffer Setpoint + 5 K). The heating buffer is fully charged (buffer discharge deactivated).

", on page 228.

### **Buffer storage sensor**

One or two buffer sensors (BS1 / BS2) can be connected to the control system. If a second buffer sensor (BS2) is connected, stratified discharging of the heating buffer can be implemented.

### **Supply (parameter)**

The *Supply* parameter specifies to which energy source a Request from the buffer storage is directed to.

- *Off*: No energy source. In general charging of the heating buffer is uncontrolled (solid fuel boiler or solar).
- *Energy generator*: Heating buffer charging takes place actively via the energy generator.



## 9.7.2 Function description – charge control

Charge control refers to the process of the active heating buffer charge via the energy generator.

- Without a charging release, the heating buffer load Pump is shut down.
- A forced activation of the heating buffer loading Pump leads automatically to charging release.
- As soon as a Request exists at the heating buffer and the heating buffer temperature falls below the Request value, the heating buffer Pump is switched on, provided the Pump is not blocked by the boiler start protection.
- The heating buffer load Pump is switched off after the overrun time, once the heating buffer temperature exceeds the Request value plus the switching difference.
- If the maximum temperature is exceeded at the heating buffer sensor 1 (top) or heating buffer sensor 2 (bottom), then the heating buffer load Pump, is immediately switched off. Renewed switching to the normal buffer control takes place when the temperatures has fallen below the maximum temperature at the heating buffer sensor 1 (top) and the heating buffer sensor 2 (bottom) by 2 K.
- If the maximum temperature is exceeded and forced draining is activated, then the consumer circuits that are supplied by the heating buffer are informed of this, and are regulated to their maximum temperature.
- Setpoints below the minimum temperature are automatically raised to the minimum temperature.
- Setpoints above the maximum temperature are automatically limited to the maximum temperature.
- Once a Request value is submitted to the energy generator, it remains at least until the minimum temperature plus the set heating buffer switching difference has been reached.
- Absorption (permanent absorption function):  
Except for charging operation (Setpoint reached), constant checking for possible absorption is performed as soon as the set absorption temperature of the energy generator is exceeded. The temperature difference between the energy source flow temperature and the actual highest heating buffer temperature is monitored.
  - If the temperature difference increases above the set overrun power on difference, the heating buffer load Pump (absorption function) switches on.
  - If the temperature difference falls to the overrun Switch-off difference, the heating buffer load Pump is switched off immediately.
- If the anti-lock system/corrosion protection system is activated for the heating buffer Pump, the Pump is switched on after 24 hours standstill for 20 seconds.
- If there is a defect in a heating buffer sensor, the buffer load Pump (BULP) is switched on.
- The energy generator start protection only acts on the buffer load Pump (BULP).
- If buffer start protection is activated and the heating buffer temperature is below the minimum temperature - 2 K, then the consumer circuits receive a blocking signal for use of the heating buffer.
- The buffer discharge protection cOffes blocking of the buffer load Pump until the energy generator temperatures has reached the buffer Setpoint + 5 K. The buffer charging Pump is then switched off.
- The set increase is for compensation of the heat losses between the energy generators and the heating buffer. The set increase is always applied to the Request value. Thus generally the Request value is equal to the Setpoint + increase.
- In manual mode, the heating buffer load Pump is switched on until the heating buffer maximum temperature is reached.

### Charging release

The term charging release brings together all conditions that must be fulfilled so that charging of the heating buffer can be carried out.

- Hydraulic implementation:  
Charging release is only granted to the heating buffer, if the hydraulic implementation provides charge control.

### Start protection of the energy generator

If an energy generator signals a (heating) start protection, then the heating buffer charging release is withdrawn.

#### 9.7.2.1 Forced switch-on

The buffer load Pump can be switched on directly via forced switch-on without consideration of Setpoints and thermal conditions. For example, the forced switch-on can be performed if an energy generator signals a forced draining into the heating buffer. However, the forced switch-on is ended when the heating buffer maximum temperature is reached.

#### 9.7.2.2 Frost protection function

As soon as the heating buffer sensor BS1 (top) or (if configured) the heating buffer sensor BS2 (bottom) signals a temperature below the heating buffer frost protection temperature (5°C), the buffer load Pump is automatically switched on. Frost protection ends when both heating buffer sensors have exceeded the minimum temperature.

- *Buffer load Pump forced switch-on ON:*  
BS1 < 5°C or BS2 < 5°C
- *Buffer load Pump forced switch-on OFF:*  
BS1 > Minimum temperature + switching difference and BS2 > Minimum temperature + switching difference

---

#### NOTE

The second heating buffer sensor (bottom) is only considered if it also configured.

---

#### 9.7.2.3 Stratified charging

As soon as two heating buffer sensors are configured, heating buffer charging takes place using stratified charging.

- The heating buffer generates a heat Request, if the maximum heating buffer temperature (BS1 or BS2) is **less** than the buffer Setpoint.
- The heating buffer retracts the heat Request, if the lowest heating buffer temperature (BS1 or BS2) is **greater** than the buffer Setpoint.

---

#### NOTE

The heating buffer sensor BS1 is always installed at the *top* in the heating buffer.

The heating buffer sensor BS2 is always installed at the *bottom* in the heating buffer.

---

#### 9.7.2.4 Absorption function

If no Request value exists for the heating buffer, then permanent checking of the temperature difference between the energy source flow temperature and the heating buffer temperature takes place.

If the temperature difference increases above the set switch-on difference of the absorption function, the buffer load Pump (BULP) switches on.

If the temperature difference falls to the set Switch-off difference of the absorption function, the buffer load Pump is switched off immediately.

- *Buffer load Pump ON:*  
(Energy source flow temperature – Heating buffer temperature) > Absorption function power on difference.
- *Buffer load Pump OFF:*  
(Energy source flow temperature – Heating buffer temperature) < Absorption function Switch-off difference.

---

#### NOTE

The absorption function can be activated directly after active charging of the heating buffer and thus be superimposed on the normal overrun time.

Once the absorption function is activated, the set overrun time of the buffer load Pump is ignored.

---

#### 9.7.2.5 Hydraulic buffer discharge (HBD)

In buffer charging systems without buffer discharge, the buffer storage is charged by the energy generator before the heating circuits can remove energy.

Through hydraulic buffer discharge, first the top buffer area is charged and the heating circuits are enabled. Then the HBD valve switches over so that the whole buffer is charged.

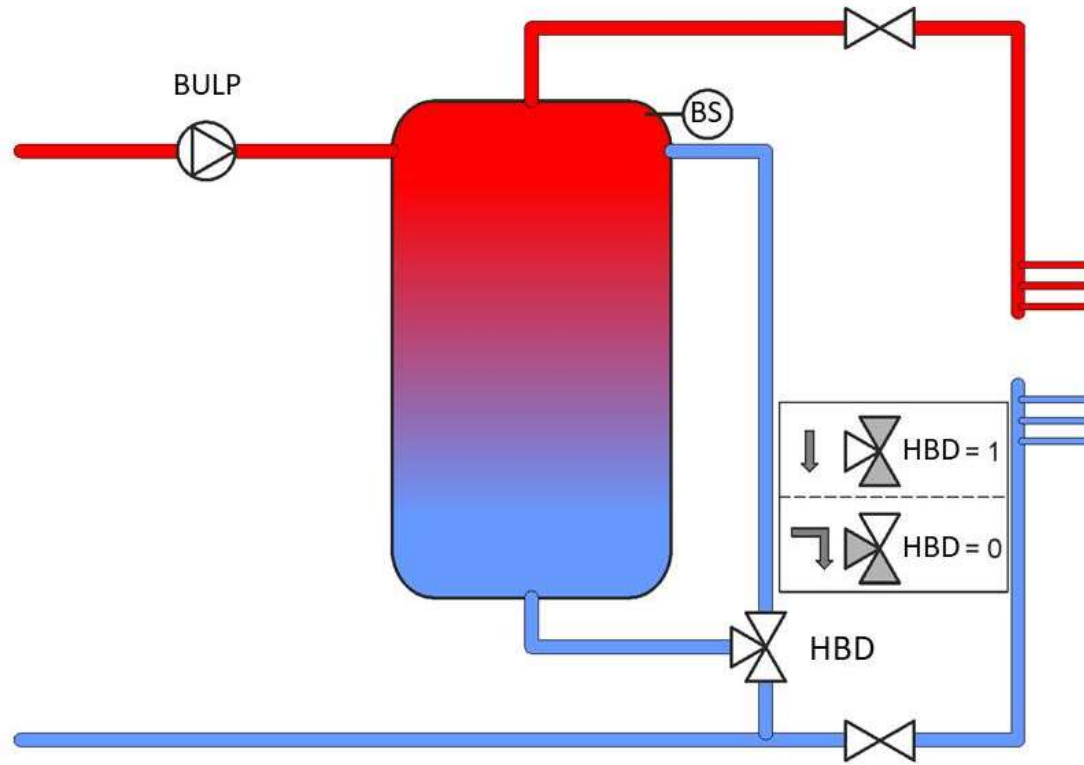

Fig. 51: Example hydraulic scheme, Hydraulic buffer discharge HBD

The switching difference for switching of the output is fixed at 5 K and is independent of the buffer switching difference.

- HBD output "ON": Temperature BS < Buffer Setpoint. The heating buffer is only partially loaded (buffer discharge activated).
- HBD output "OFF": Temperature BS > ( Buffer Setpoint + 5 K). The heating buffer is fully charged (buffer discharge deactivated).

### 9.7.3 Function description – discharge control

Discharge control refers to the process of active heating buffer discharge by the consumer circuits and via the heating buffer discharge Pump/valve.

- Without a discharging release, the heating buffer discharging Pump is shut down.
- Without a Setpoint from the consumer circuits (heating circuits, hot water) the heating buffer discharging Pump is shut down.
- If the maximum temperature is exceeded at the heating buffer sensor BS1 (top) or heating buffer sensor BS2 (bottom), then the heating buffer discharging Pump is immediately switched on (forced draining). Renewed switching to the normal buffer control takes place when the temperatures has fallen below the maximum temperature at the heating buffer sensor BS1 (top) and the heating buffer sensor BS2 (bottom) by 2 K.

- If the maximum temperature is exceeded and forced draining is activated, then the consumer circuits provided for forced draining are switched on, and are regulated to their maximum temperature.
- Setpoints below the minimum temperature are automatically raised to the minimum temperature.
- Setpoints above the maximum temperature are automatically limited to the maximum temperature.
- If buffer start protection is activated and the heating buffer temperature is below the minimum temperature – 2 K, then the consumer circuits receive a blocking signal for use of the heating buffer and the heating buffer discharge Pump is immediately switched off.
- The buffer start protection is cleared when the hot buffer temperature has exceeded the minimum temperature + (switching difference/2).
- No charge temperature increase acts on the Setpoint.
- If a heating buffer sensor defect occurs, the heating buffer discharge Pump switches off immediately.
- If the anti-lock system/corrosion protection system is activated for the heating buffer Pump, the Pump is switched on after 24 hours standstill for 20 seconds.
- In manual mode, the heating buffer discharge Pump is permanently switched off.

#### **Brief description discharge control type 1**

If *Discharge control 1* is selected, the following points also apply:

- The heating buffer discharge Pump is switched on, if the maximum heating buffer temperature has exceeded Setpoint plus switching difference.
- The heating buffer discharge Pump is immediately switched off, when the lowest heating buffer temperature falls below the Setpoint.
- Moreover, the boiler start load reduction acts on the heating circuits as soon as a heat generator Request exists.

#### **Brief description discharge control type 2**

If *Discharge control 2* is selected, the following points also apply:

- The heating buffer load Pump only becomes active, if there is a Request to the energy source.
- The heating buffer discharge Pump is switched on, if the maximum heating buffer temperature has exceeded the energy source buffer temperature plus + 5 K.
- The heating buffer discharge Pump is immediately switched off, when the lowest heating buffer temperature falls below the temperature at the energy source discharge flow sensor.
- Activation only upon Request to the energy generator:
  - *Switch on:*  $BS_{max} > GEN-Flow + 5K$  and  $GEN-Flow < GEN-Setpoint$
  - *Switch-off:*  $BS_{min} < GEN-Flow$  or  $GEN-Flow > (GEN-Setpoint + Switching\ difference\ OFF)$
- Energy generator source
  - *Blocking ON:* If the heating buffer discharge Pump is active.
  - *Blocking OFF:* If the heating buffer discharge Pump is deactivated and  $GEN-Flow < GEN-Setpoint$  and  $BS_{max} < (GEN-Flow + 5\ K)$

#### **Discharging release**

The term discharging release brings together all conditions that must be fulfilled so that discharging of the heating buffer can be carried out.

- Hydraulic implementation:  
Discharging release is only granted to the heating buffer, if the hydraulic implementation provides discharge control.

## 9.7.4 Hydraulic examples – heating buffer function

### 9.7.4.1 Buffer charge control for heating circuit and hot water Requests

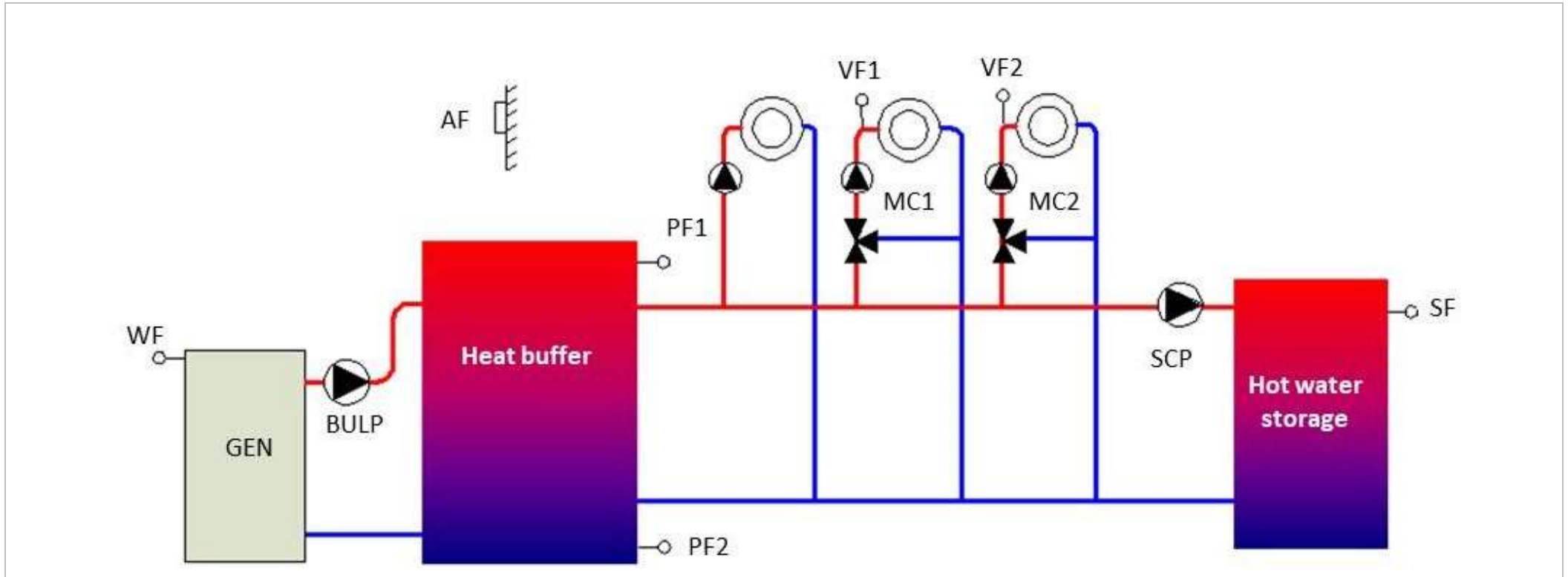

Fig. 52: Buffer charge control with heating circuit and hot water Requests

Function	Description
Function	Selection of the heating buffer function. Setting: <i>Charge control</i>
Request	Heating circuit / hot water
Heat generator Request	Heating buffer
Soft starting	Heating circuit and hot water
Discharge protection monitoring	Active

Function	Description
Frost protection monitoring	Active
Minimum temperature monitoring	Active
Maximum temperature monitoring	Active
Forced draining	Heating circuit / hot water
Absorption function (overrun time switching difference)	Active
Charge temperature increase for energy management	Heating circuit / hot water
Boiler start protection on buffer load Pump	Active
Manual mode for buffer load Pump	On
Emergency mode for buffer load Pump if sensor defective	On

9.7.4.2 Solid fuel regulation with buffer storage solar system with solar charge valve

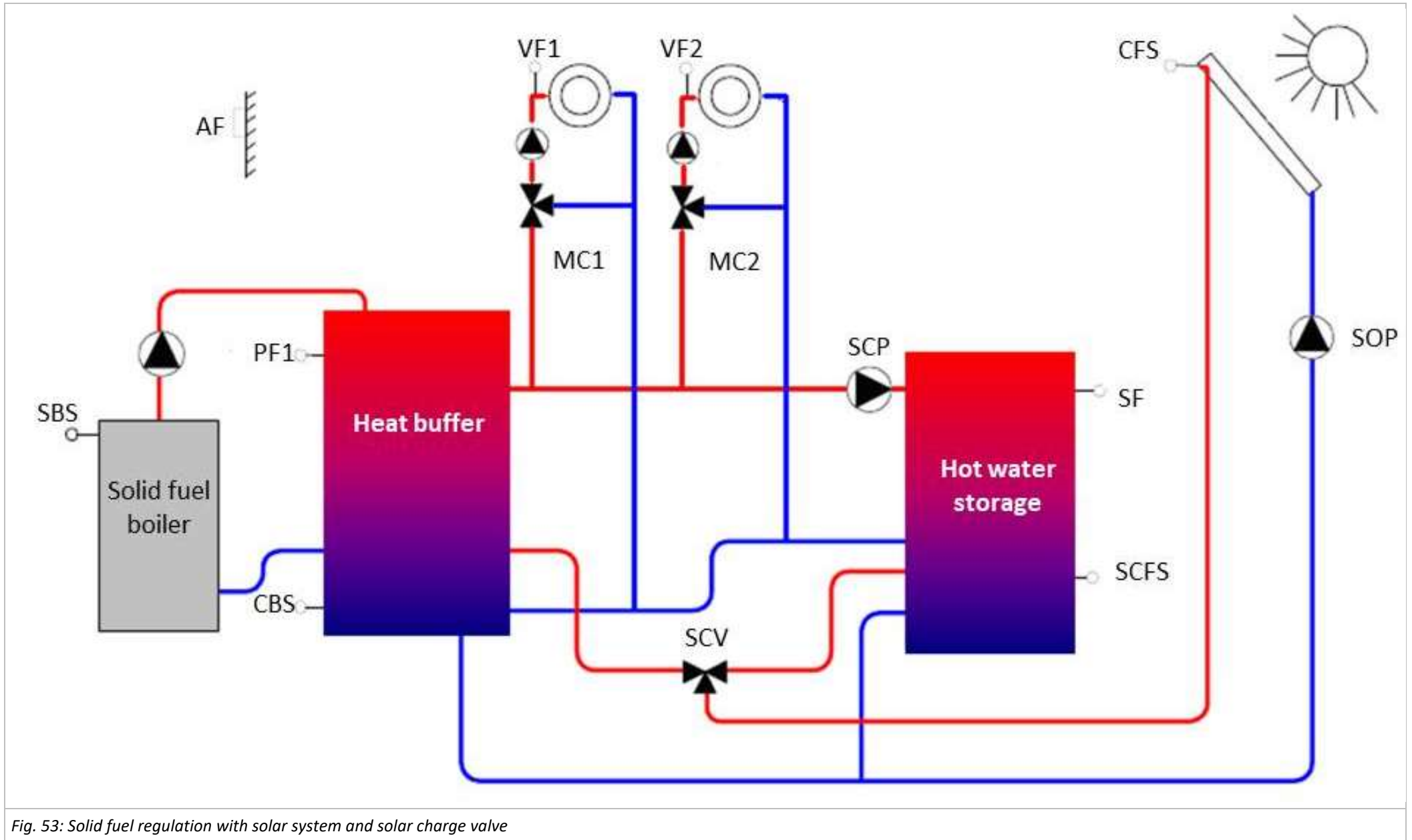

Fig. 53: Solid fuel regulation with solar system and solar charge valve



### 9.7.4.3 Buffer charge control (BULP) for heating circuit and hot water with solid fuel regulation

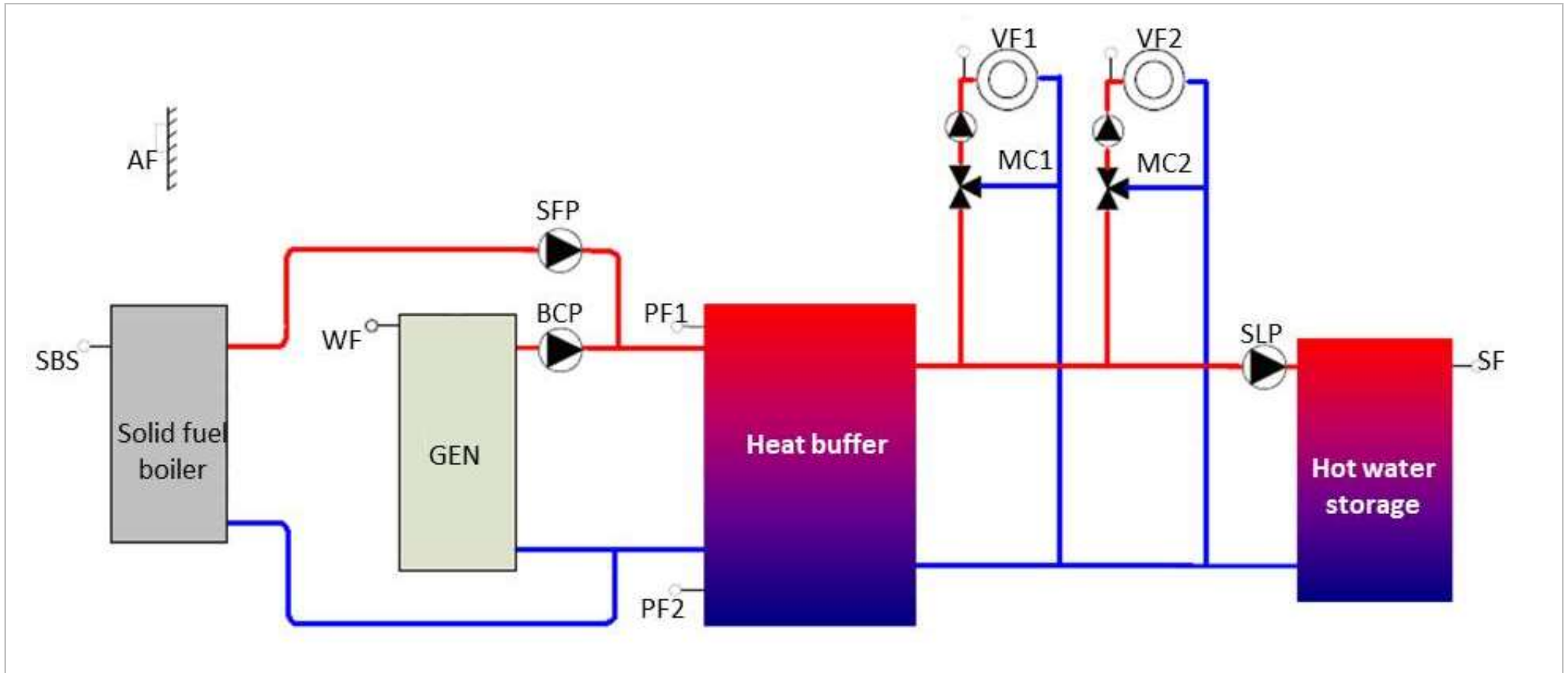

Fig. 54: Buffer charge control with solid fuel boiler for heating circuit and hot water

9.7.4.4 Buffer charge control (BULP) for heating circuit Requests

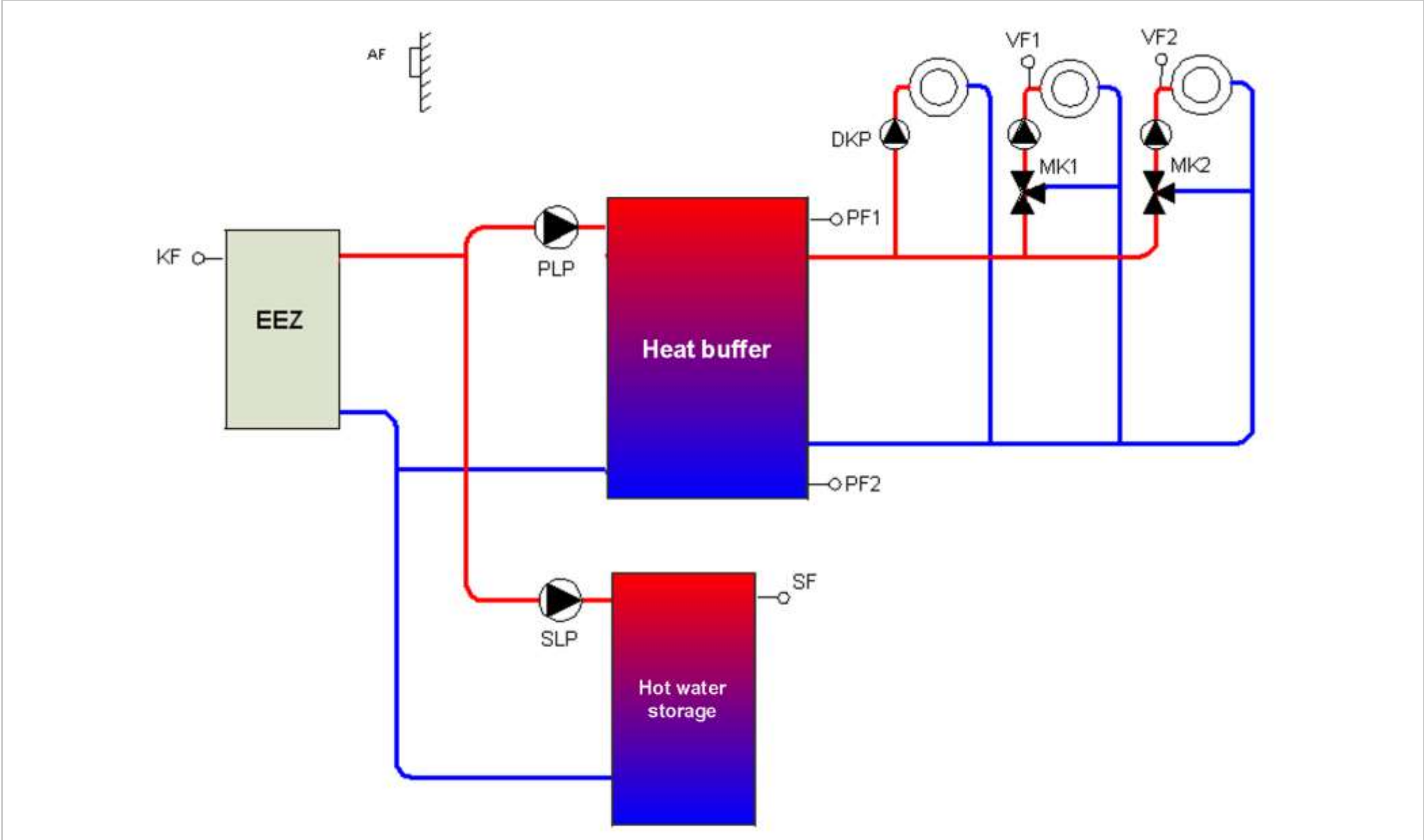

Fig. 55: Buffer charge control for heating circuit Request

Function	Description
Function	Selection of the heating buffer function. Setting: <i>Charge control</i>
Request	Heating circuit
Heat generator Request	Heating buffer / hot water
Soft starting	Heating circuit
Discharge protection monitoring	Active
Frost protection monitoring	Active
Minimum temperature monitoring	Active
Maximum temperature monitoring	Active
Forced draining	Heating circuit
Absorption function (overrun time switching difference)	Active (only if hot water charging is not active)
Charge temperature increase for energy management	Heating circuit
Boiler start protection on buffer load Pump	Active
Manual mode for buffer load Pump	On
Emergency mode for buffer load Pump if sensor defective	On

### Special functions

- With DHW storage priority mode activated, this function acts on the buffer loading Pump but not on the heating circuits.
- Forced draining from the buffer storage into the DHW storage is not possible.

### 9.7.4.5 Buffer charge control (BULP) with hot water diverter valve

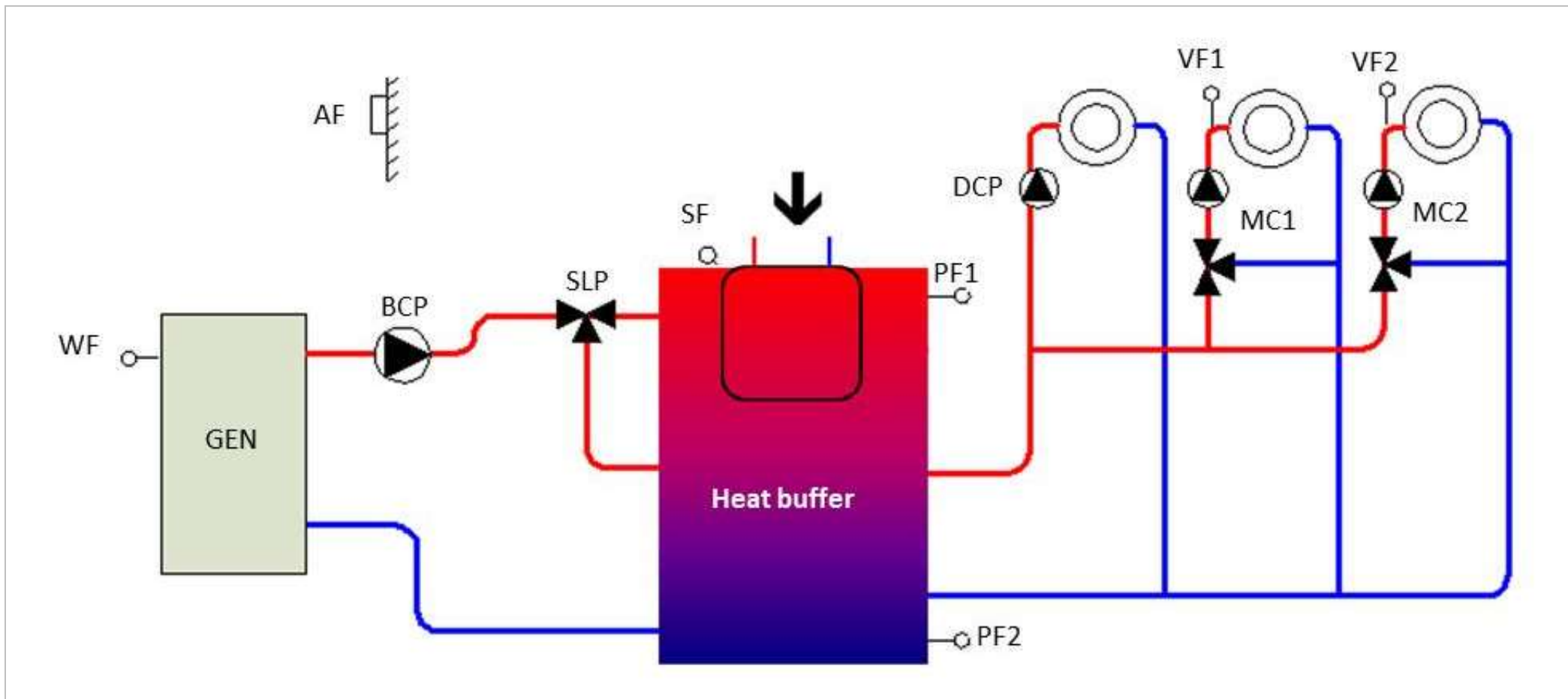

Fig. 56: Buffer charge control with hot water diverter valve

Function	Description
Function	Selection of the heating buffer function. Setting: <i>Charge control</i>
Request	Heating circuit
Heat generator Request	Heating buffer / hot water
Soft starting	Heating circuit

Function	Description
Discharge protection monitoring	Active
Frost protection monitoring	Active
Minimum temperature monitoring	Active
Maximum temperature monitoring	Active
Forced draining	Heating circuit
Absorption function (overrun time switching difference)	Active (only if hot water charging is not active)
Charge temperature increase for energy management	Heating circuit
Boiler start protection on buffer load Pump	Active
Manual mode for buffer load Pump	On
Emergency mode for buffer load Pump if sensor defective	On

#### Special functions

- The buffer load Pump is also switched on with hot water charging.
- The hot water priority does not affect the heating circuit.
- The hot water discharge protection acts on the BULP and the TCP switches directly on Request receipt.
- The boiler soft start does not affect the TCP, rather only the BULP
- Forced draining from the buffer storage into the DHW storage is not possible.

### 9.7.4.6 Buffer discharge control with heating circuit and hot water Requests

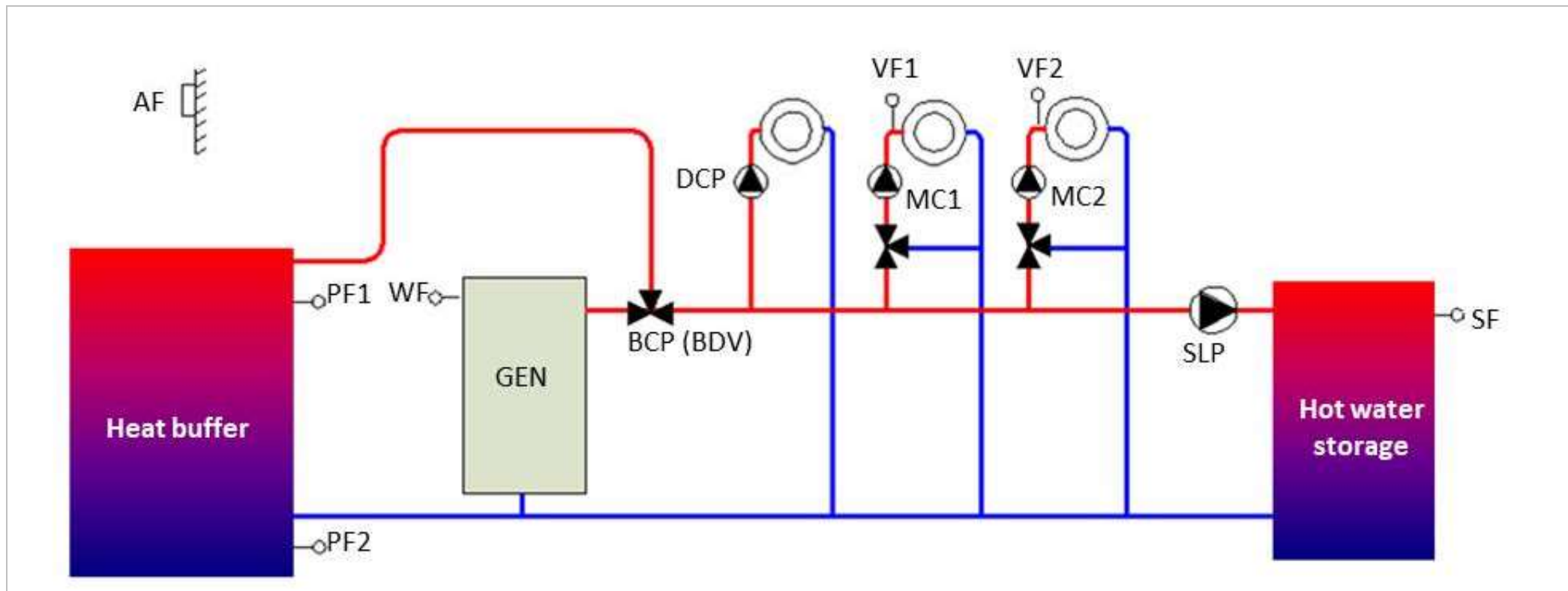

Fig. 57: Buffer discharge control to heating circuit and hot water

Function	Description
Function	Selection of the heating buffer function. Setting: <i>Discharge control 1</i> The output BULP is used for actuation of a buffer discharge valve (PEV).
Request	Heating circuit / hot water
Heat generator Request	Heating buffer
Soft starting	Heating circuit / hot water
Discharge protection monitoring	Passive
Frost protection monitoring	Passive

Function	Description
Minimum temperature monitoring	Active
Maximum temperature monitoring	Active
Forced draining	Heating circuit / hot water
Absorption function (overrun time switching difference)	Passive
Charge temperature increase for energy management	Passive
Boiler start protection on buffer load Pump	Passive
Manual mode for buffer load Pump	Off
Emergency mode for buffer load Pump if sensor defective	Off
Forced switch-on for heat generator blocking	Active

#### Special functions

- The buffer discharge valve (PEV) is switched off when there is no Request from the heating circuits and from hot-water loading.
- A boiler soft start on the heating circuit is cleared by the discharge process of the buffer.

### 9.7.4.7 Buffer discharge control on heating circuit Requests

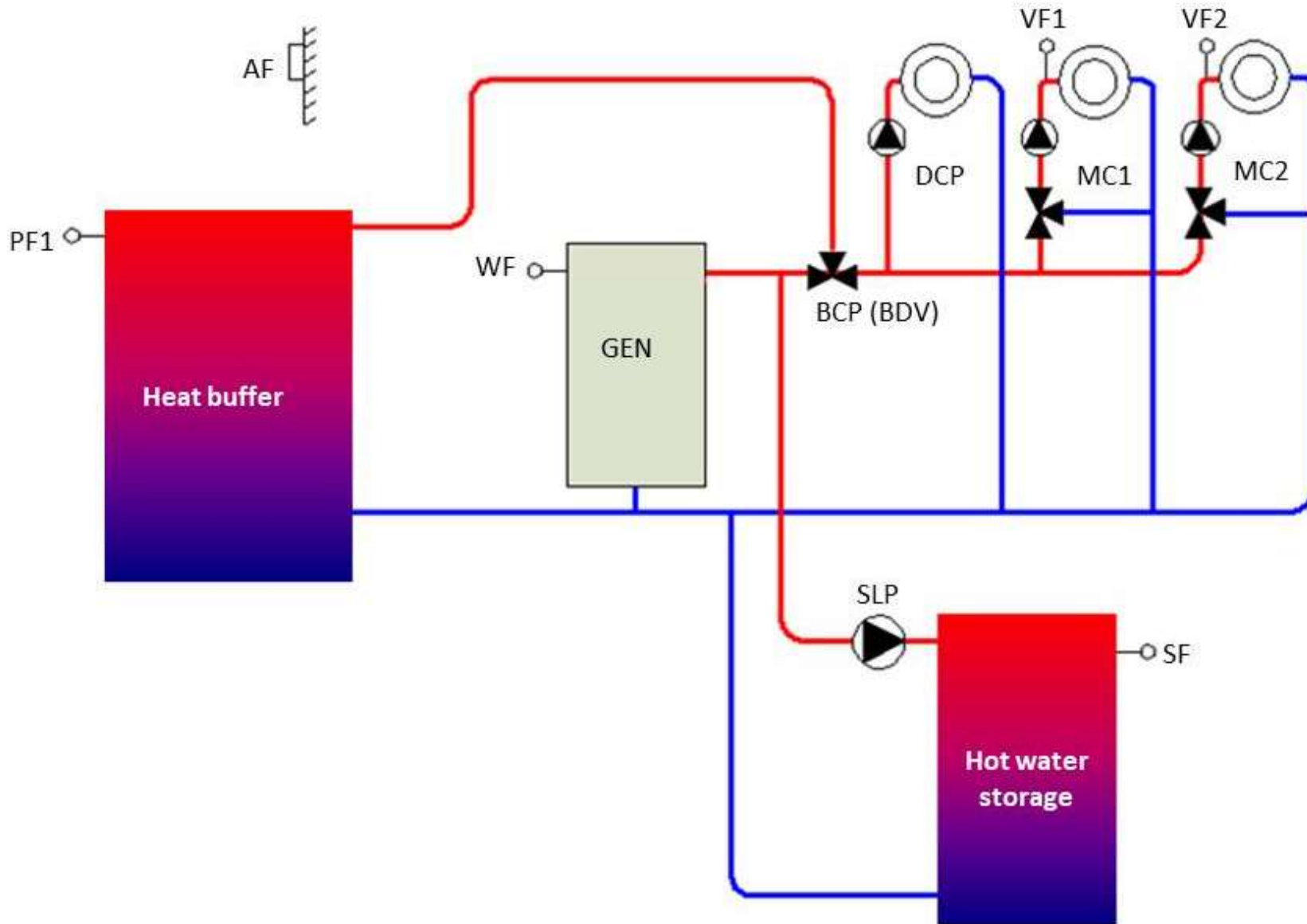

Fig. 58: Buffer discharge control on HC



Function	Description
Function	Selection of the heating buffer function. Setting: <i>Discharge control 1</i> The output BULP is used for actuation of a buffer discharge valve (PEV).
Request	Heating buffer / hot water
Heat generator Request	Heating buffer
Soft starting	Heating circuit
Discharge protection monitoring	Passive
Frost protection monitoring	Passive
Minimum temperature monitoring	Active
Maximum temperature monitoring	Active
Forced draining	Heating circuit
Absorption function (overrun time switching difference)	Passive
Charge temperature increase for energy management	Passive
Boiler start protection on buffer load Pump	Passive
Manual mode for buffer load Pump	Off
Emergency mode for buffer load Pump if sensor defective	Off
Forced switch-on for heat generator blocking	Active

### Special functions

- The buffer charge valve is switched off when there is no Request from the heating circuits.
- Hot-water priority only acts on the heating circuits when there is no buffer discharge in progress.
- A boiler soft start on the heating circuit is cleared by the discharge process of the buffer.
- Forced draining from the buffer storages into the DHW storage is not possible.

### 9.7.4.8 Buffer discharge control type 2 on heat generator

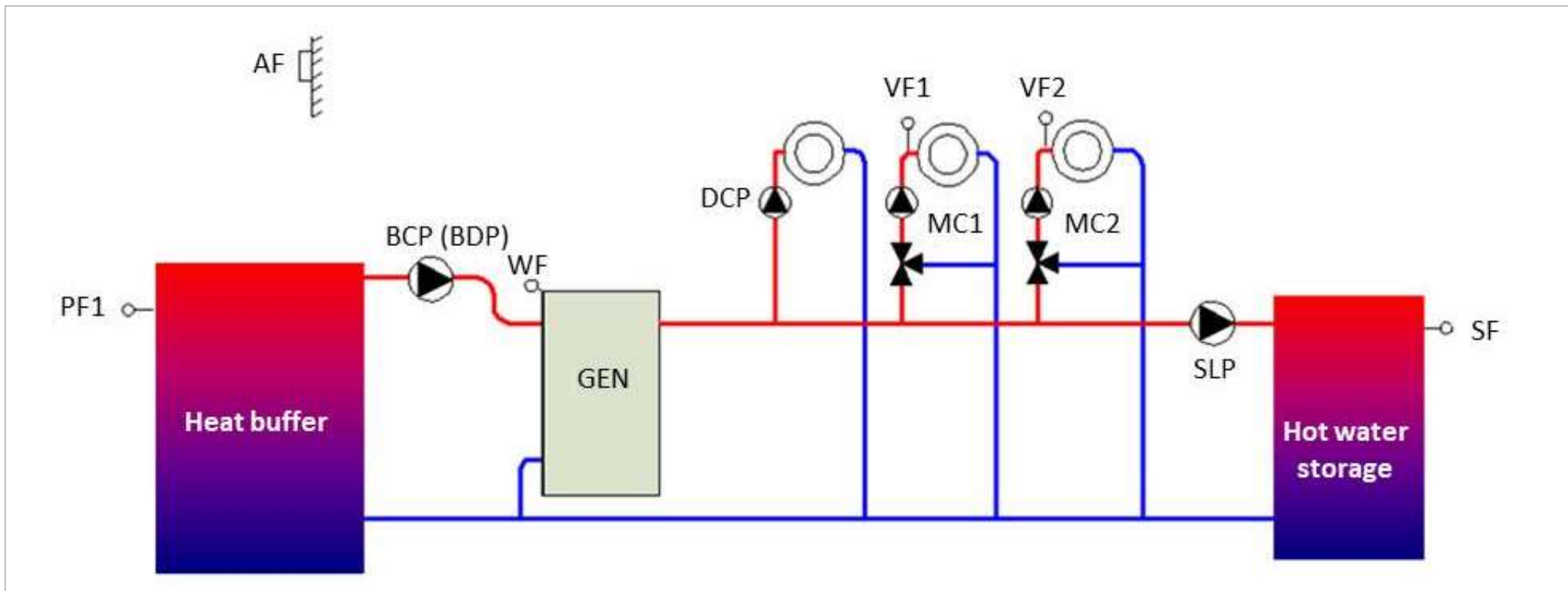

Fig. 59: Buffer discharge control type 2 on heat generator

Parameter / function	Description
Function	Selection of the heating buffer function. Setting: <i>Discharge control 2</i> The output BULP is used for actuation of a buffer discharge valve (PEV).
Request	Passive
Heat generator Request	Heating circuit / hot water
Soft starting	Passive
Discharge protection monitoring	Passive
Frost protection monitoring	Passive

Parameter / function	Description
Minimum temperature monitoring	Passive
Maximum temperature monitoring	Active
Forced draining	Heating circuit / hot water
Absorption function (overrun time switching difference)	Passive
Charge temperature increase for energy management	Passive
Boiler start protection on buffer load Pump	Passive
Manual mode for buffer load Pump	Off
Emergency mode for buffer load Pump if sensor defective	Off

#### Special function

- A discharge into the heat generator only takes place if a Request from the heating circuits (Request to the heat generator) exists or the buffer maximum temperature monitoring has triggered.

## 9.8 Differential control (solar, solid fuel, and general differential control)

Menu	Parameter	Description
Expert/ Configuration / Function / Difference 1 ... 3	Function	Selection of the type of differential control. Solar, solid fuel or differential control
Expert / Solar, Solid, Differential / Basic settings	Switch on difference	Configuration of differential control.
	Switch-off difference	
	Minimum temperature	
	Maximum temperature	
	Limit stop	
	Storage maximum temperature	
	Operation mode	
	Time lock	
	Frost protection (solar)	
	Recooling (solar)	
	Forced draining	
Expert / Solar, Solid, Differential / Pump	Minimum runtime	Configuration of the Pump function for differential control.
	Break time	
	Anti-lock system	
	Manual driving	

The control function *Differential control* controls a switching output based on the difference between two temperatures.

The *heatcon!* system offers up to three differential controls. A specification of the differential controls to solar and solid fuel is not undertaken, thus it is possible to activate three solar systems or three solid fuel systems or three differential controls.

Important applications for differential controls are the incorporation of solar thermal systems, solid fuel boilers or the de-stratification of two storages.

Pre-configuration is possible via the setup wizards.

The following parameters influence the behaviour of the control function. The individual parameters are described in detail in this chapter.

### Switch on difference

The parameter *power on difference* specifies the temperature difference, that must at least be present between the flow and the storage (return flow sensor) so that the Pump switches on.

### **Switch-off difference**

The parameter *Switch-off difference* specifies the temperature difference, that must at least be present between the flow and the storage (return flow sensor) so that the Pump, taking into consideration the minimum runtime and the overrun time switches off. The minimum difference between the power on and Switch-off difference is 3 K.

### **Flow minimum temperature**

The parameter *Flow minimum temperature* specifies from which temperature limit the differential control is released. As long as the flow minimum temperature has not exceeded this value, differential monitoring remains inactive.

If the flow temperature exceeds the minimum value a direct shutdown occurs with adhering to the minimum runtime or overrun time.

### **Flow maximum temperature**

The *Maximum Temperature* parameter provides protection. If it is exceeded, the forced start-up of a Pump occurs.

If the temperature falls below the flow maximum temperature by 5 K, and allowing for the minimum runtime, differential control is again enabled. The excess energy is diverted into the storage; here, it must be **NOTE**d that exceeding of the storage maximum temperature has priority.

This means that in spite of exceeding of the flow maximum temperature, the Pump remains switched off or is switched off, as soon as the DHW storage temperature exceeds the maximum temperature.

### **Limit stop temperature**

The Pump started up by the exceeding of the flow maximum temperature, is again shut down in the final switch-off temperature is exceeded.

The final switch-of temperature has priority over the flow maximum temperature limit. A forced shutdown can be prevented if the setting of the final switch-off temperature is set below the setting of the flow maximum temperature.

### **DHW storage maximum temperature**

The *DHW maximum temperature* parameter ensures the storage is protected. If it is exceeded, an operating charging Pump is immediately shut down. The forced shutdown is only cleared again when the temperature falls 2 K below the maximum temperature.

### **Operation mode**

The *Operation mode* parameter specifies the influence on the active Energie generator with the following settings.

Selection	Description
<i>Parallel mode</i>	Without active influence on the active energy generator.
<i>GEN priority mode</i>	During a differential charge all Requests to the active energy generator are suppressed.
<i>DHW priority mode</i>	During a differential charge, a Request from the DHW storage to the active energy generator is suppressed.
<i>BS priority mode</i>	During a differential charge a Request from the heating buffer to the active energy generator is suppressed.

### Time lock

The *Time lock* parameter prevents the energy generator being started up for an adjustable time.

The setting value of the time lock specifies the time for which the energy generator remains blocked after ending of a differential charge.

### Frost protection (only for solar type)

The parameter *Frost protection* sets the temperature limit for activation of the frost protection function. If *OFF* is selected, the frost protection function is deactivated.

If the frost protection in the medium of a solar thermal system is not sufficient, frost protection is provided by back heating in the collector.

- The solar charging Pump is switched on if the collector temperature is below the set solar frost protection temperature.
- The solar charging Pump is switched off if the collector temperature is above the set solar frost protection temperature + 2.5 K.
- The activated frost protection function has no effect on the heat consumption measurement and runtime meter.
- The minimum runtime of the solar circuit Pump is not considered.
- An existing frost protection Request does not trigger burner blocking or a time lock.
- If there is a defect in the flow sensor during a frost protection function, the solar circuit Pump switches off.

### Recooling (only for solar type)

The parameter *Recooling* sets the temperature limit for activation of the recooling function. If *OFF* is selected, the recooling function is deactivated.

During the summer months, very strong sunshine can result in overheating of the storage(s). The recooling function is active to give the system the possibility of reducing the temperature during the night or when the sunshine reduces.

With this function, the solar circuit Pump / SOP valve is switched dependent on the storage temperature SBUS and the collector temperature SCFS.

As soon as the temperature at the SBUS has fallen below the storage maximum temperature by the set recooling difference, the solar charging Pump is switched off and/or the valve closed.

- *Solar circuit Pump On*: When the storage temperature (SBUS) has exceeded the storage maximum temperature and collector temperature at the SCFS is below 40°C.
- *Solar circuit Pump Off*: When the temperature at the SBUS has fallen below the storage maximum temperature by the set recooling difference.

### Forced draining

The parameter *Forced draining* is used to select the target for the forced draining of excess energy.

If the set storage maximum temperature in the buffer storage is exceeded, the excess energy is dissipated as configured. This prevents overheating of the energy generator.

DHW, heating circuits, heating buffers (only for configuration with charging control) are possible targets. Alternatively, a relay output can be selected with External, via which the energy can be forwarded via a Pump to a lower level buffer storage.

#### NOTE

---

When assigning of the forced draining, ensure that the hydraulic scheme enables forced dissipation into the selected area.

---

#### Parallel connection

The value entered here is subtracted from the actual Request value (at GEN, DHW, buffer). This reduced “Setpoint” is forwarded to the energy generator as a Request value.

If priority parallel connection is used and the energy generator is blocked by the “Priority mode” Operation mode, a direct release of the energy generator takes place upon undershooting of Setpoint-reduced Request value with the specified switching difference. This even occurs if a time lock is active.

If the actual temperature of the energy generator now exceeds the Setpoint (without Setpoint reduction) with the entered switching difference, a switchover to priority mode occurs.

The actual temperature and the Setpoint refer according to the set priority operation mode

- to the buffer if a buffer charging Pump is present,
- to the hot water tank if a storage tank charging Pump is present.

#### Behaviour in the event of an error

A defect (open circuit/short circuit) of a flow or storage sensor effects the Pump function dependent on the type of differential control.

Sensor defect	Type: Solar	Type: Solid fuel	Type: Differential
Flow sensor	Solar Pump: OFF	Sold fuel Pump: ON	Differential Pump: OFF
Buffer storage sensor	Solar Pump: OFF	Sold fuel Pump: OFF	Differential Pump: OFF

The forced shutdown of the Pump takes place subject to adhering to the set minimum runtime.

### 9.8.1 Differential control solar – double buffer system with charge valve switchover

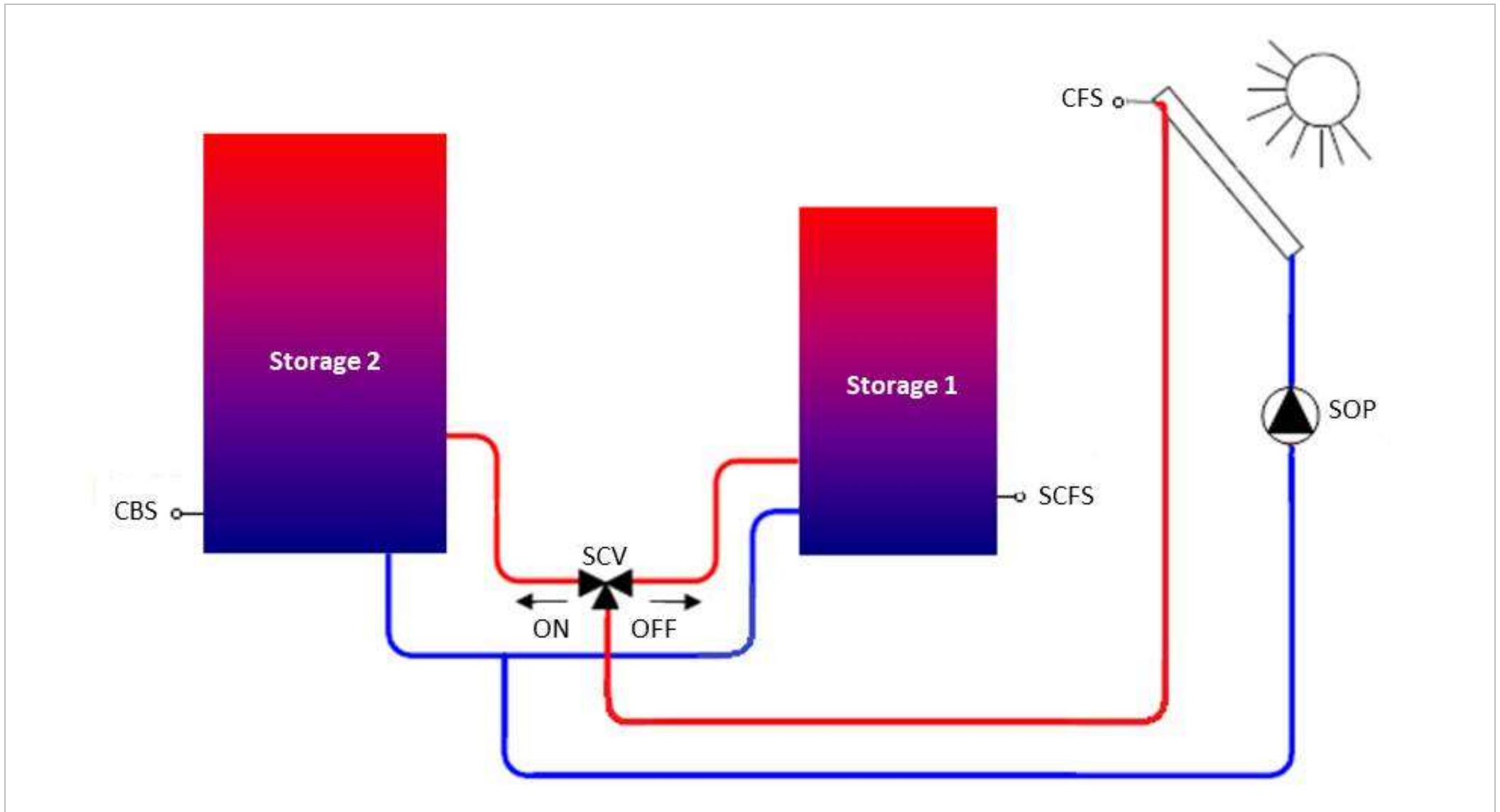

Fig. 60: Double buffer system of a solar thermal system (example)

In systems that have both an external hot water storage and a buffer storage, a diverter valve (SLV) can be used to switch between loading the hot water storage and loading the buffer storage from the solar thermal system.



The purpose of this valve is to ensure that the use of solar energy for hot water heating is prioritised.

Only after the DHW storage is charged does a changeover to the buffer storage occur, which can then accept the still supplied energy up to the point when the storage maximum temperature is reached.

#### **Changeover time**

The changeover of the diverter valve of the buffer to the hot water charging takes place cyclically at fixed intervals of 30 minutes. A check is now performed to determine whether hot water charging can be carried out by the collector. To do so, the valve remains for at least the specified changeover time (test cycle) at the hot water setting. Once the test cycle is completed, a changeover back to the buffer storage takes place.

If, in the meantime, the switch-on requirement for charging the DHW storage is fulfilled (storage 1), charging of the DHW storage is started immediately.

#### **Changeover temperature**

The changeover temperature specifies the temperature level of storage 1. The temperature is measured by the solar charge valve sensor (SLVS).

### 9.8.2 Differential control solar – double collector array

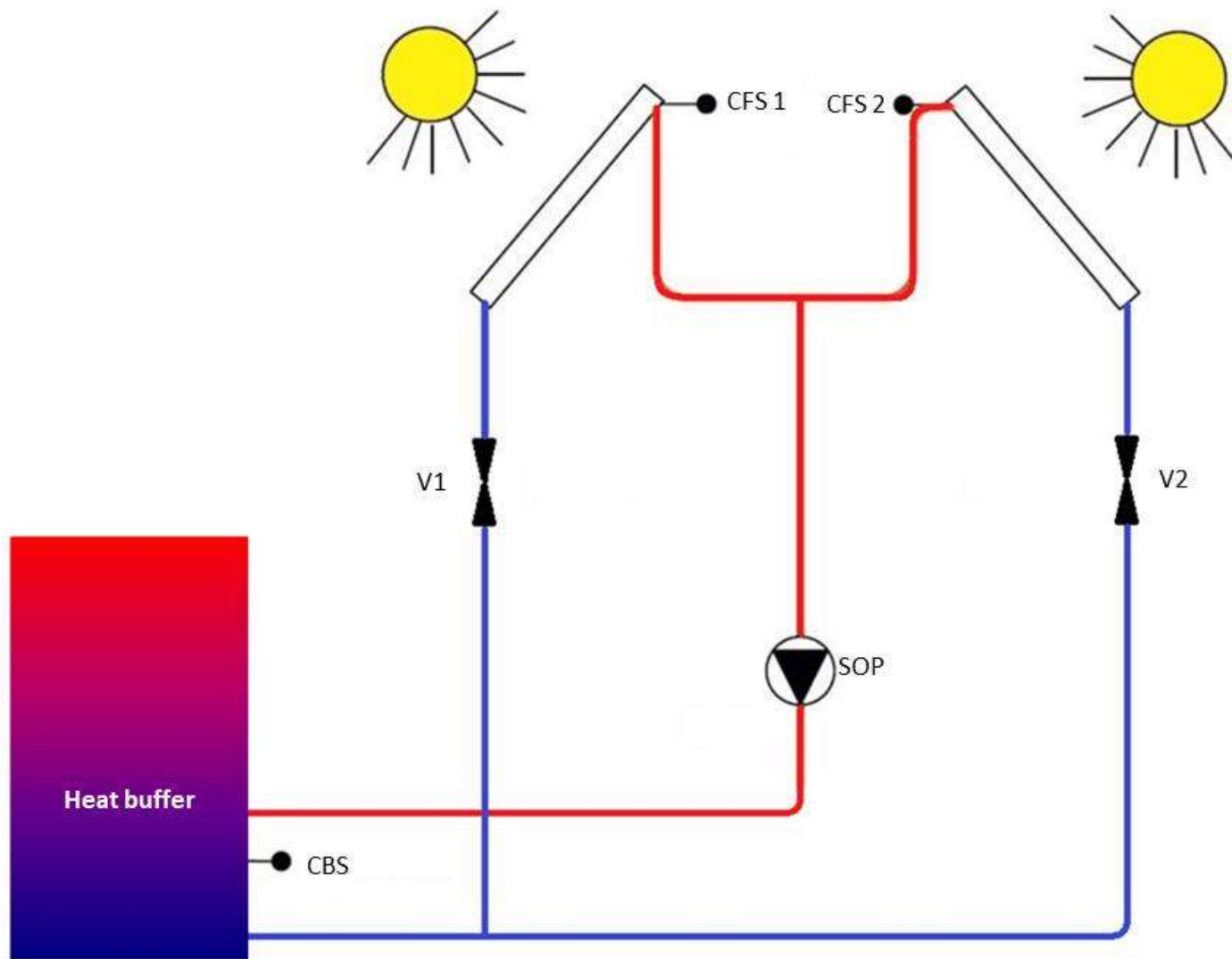

Fig. 61: Solar - double collector array (example)

A double collector array works with a central solar charging Pump (SOP). Dependent on the temperature difference V1 or V2 is released.

The output of the solar circuit Pump (main solar circuit Pump) is connected via a logical OR circuit with valve output V1 and V2 of the two differential controllers, i.e. if one of the two outputs (V1/V2) is active, the solar circuit Pump runs.

The valves shut according to the minimum time and overrun time. No different settings are made in the parameter configuration. Both collectors work with the same settings!

The anti-lock function also activates the outputs V1 and V2 for the set time.

### 9.8.3 Differential control solar – double collector system and double buffer system with charge valve switchover

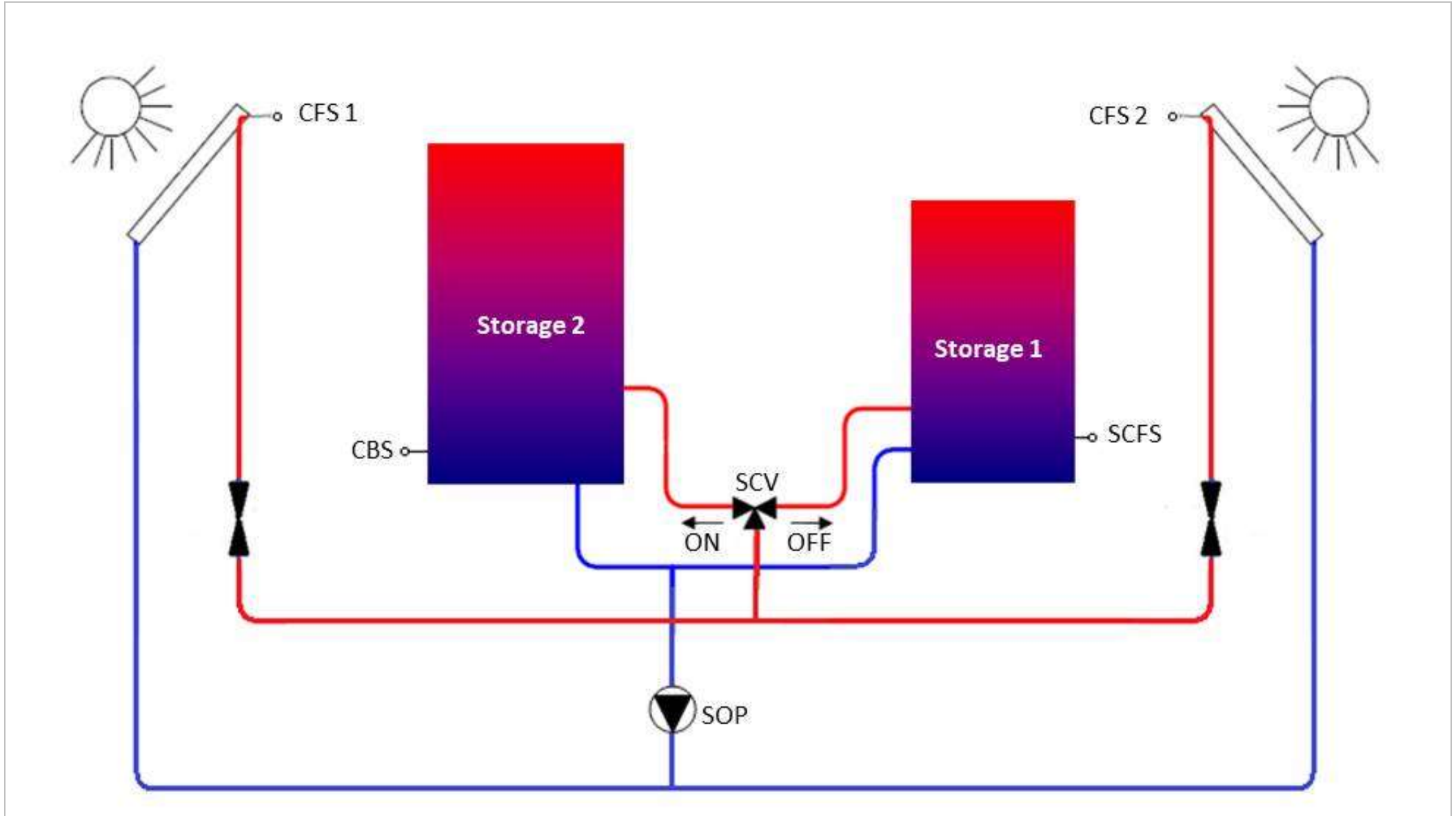

Fig. 62: Double collector system and double buffer system with charge valve switchover

The variant present here is functionally a combination of double buffer and double collector array.

#### **9.8.4 Pump – differential control**

For a function description of the Pump see section "Pump-function", on page 145.

For a function description of the Pump anti-lock function see section "Anti-lock function", on page 144.

#### **9.8.5 Heat balance – differential control**

For a function description of heat consumption measurement see section "Heat balancing", on page 150.

## 9.9 External Request

### 9.9.1 Setpoint connection via 0-10V

A Setpoint can be generated externally via a configured 0-10V input (EF10V = voltage in Setpoint temperature) using 0-10V. This is connected to a selected heating circuit, hot water or heating buffer, whereby the control Setpoints remain unchanged. The highest Setpoint is executed.

This means: If a requirement value of e.g. 35°C is required for the heating circuit from the weather conditions or room control, a Setpoint connection below this 35°C is not taken into account. Operation modes (scenes) and switching times are also not taken into account by the Setpoint connection.

In the menu Configuration - Hardware - Characteristic curve it is possible to define the characteristic diagram 0-10V (minimum V/°C and maximum V/°C).

### 9.9.2 Request contact heating buffer

It is possible to configure a Request contact (On/Off) for the heating buffer (Configuration - Function - Heating buffer). When the Request contact (On) is activated, the Setpoint for the heating buffer is set according to an adjustable constant temperature (heating buffer - basic setting). However, if there is a higher Request to the buffer from the system, it is executed. The highest Setpoint is executed.

Operation modes (scenes) and switching times are not taken into account by the Request contact.

### 9.9.3 Switching contact

By means of a switching contact to be parameterized in the Extras menu, it is possible to have this switching contact influence a room group, heating zone or hot water externally as a Request contact or modem function.

Any input can be used as a switching contact, provided it is designed as a digital input 0/1 (off/on) (see Configuration - Hardware - Input). The inputs E1- to E15 are potential-free, while the inputs E16 and E17 are controlled by a 230V signal. For these two inputs 0V = input open, 230V = input closed.

The functionality that the switch contact is to trigger for the room group, heating zone or hot water can be selected individually in the respective Room/Room group/Hot water basic setting menu.

The following functional properties exist:

	Operation mode	State	Setpoint
<b>Off</b>	Works independently of a configured switching contact.		
<b>Standby</b>	Input open:	no influence, operation according to current settings	
	Input short-circuited:	Standby operation mode	
	Heating:	Switch contact	Off/Frost protection Room frost
	DHW:	Switch contact	Setpoint 5.0°C

	Operation mode	State	Setpoint	
<b>Setback</b>	Input open:	no influence, operation according to current settings		
	Input short-circuited:	Operation mode setback		
	Heating:	Switching contact	Heating	Night Setpoint
	DHW:	Switching contact	Setpoint	Night Setpoint
<b>Heating</b>	Input open:	no influence, operation according to current settings		
	Input short-circuited:	Heating mode mode		
	Heating:	Switching contact	Heating	Day Setpoint
	DHW:	Switching contact	Setpoint	Day Setpoint
<b>Frost protection - heating (modem contact)</b>	Input open:	Operation mode standby (with AT and RT frost protection monitoring)		
	Heating:	Switching contact	Off/Frost protection	Room frost
	DHW:	Switching contact	Setpoint	5.0°C
	Input short-circuited:	Heating mode mode		
	Heating:	Switching contact	Heating	Day Setpoint
	DHW:	Switching contact	Setpoint	Day Setpoint
<b>Shutdown - heating (Request contact exclusively for heating zones, not hot water)</b>	Input open:	Total shutdown without AT and RT Frost protection monitoring. HK frost protection (5°C) is maintained.		
	Heating:	Switching contact	Shutdown	--
	Input short-circuited:	Heating mode mode		
	Heating:	Switching contact	Heating	Day Setpoint

## 9.10 Thermostat

In the configuration menu it is possible to assign an available output with a thermostat function.

This function is not assigned to any other control function and can be used as a free thermostat function.

Once an available output has been selected as a thermostat, a sensor input must be selected for the thermostat function to operate on. After configuration, a menu "Thermostat" is available for further settings.

With the adjustable Setpoint (menu Thermostat - Basic setting) the lower switching point (ON) is set. The adjustable switching difference is set to the Setpoint, from which the upper switching point (OFF) is formed.



## 10 Troubleshooting

### 10.1 Display of fault messages

Error messages are displayed in the heatapp! system depending on the end device (heatcon! MMI, heatapp! APP, PC user interface). There are two types of error messages. On the one hand, there are system error messages such as sensor errors. There are also logical error messages which indicate that a setpoint temperature has not been reached. The logical error message can be triggered by a hydraulic problem in the system, such as a defective pump or valve. The logical error messages can be activated or deactivated in the System menu.

#### **Example:**

The outside sensor connected to input SI 4 has a wire break.

According to the table "The heatcon! system offers the possibility of displaying and evaluating fault messages from a burner control system connected via a GEN bus (OpenTherm) in the *heatcon!* system.

The fault messages can be filtered in three groups or completely deactivated.

heatcon! ", on page 261: 8-4-1 = Sensor at input I4, short circuit

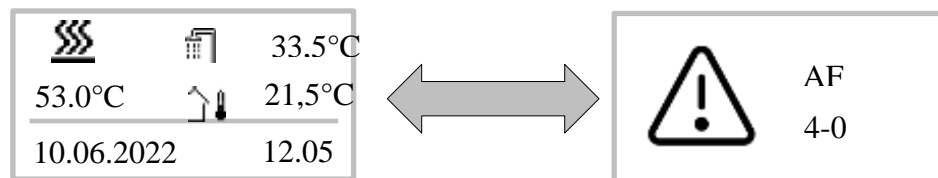

Fig. 63: Fault message in heatcon! MMI (example)

Fault messages are automatically displayed in the *heatcon!* MMI display in alternation with the basic display. If several fault messages exist simultaneously, they are displayed one after the other.

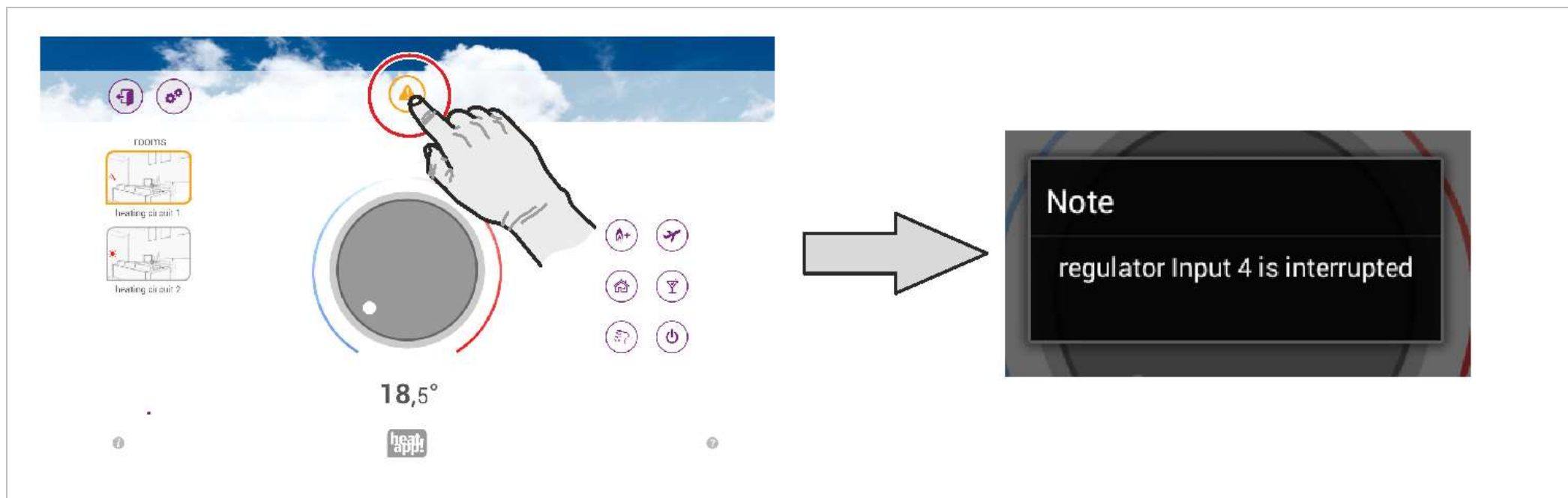

Fig. 64: Typical fault message in the heatapp! APP



In the heatapp! App, fault messages are indicated by a triangle symbol.

Tapping the symbol cOffes a message box to be displayed containing the actual fault messages.

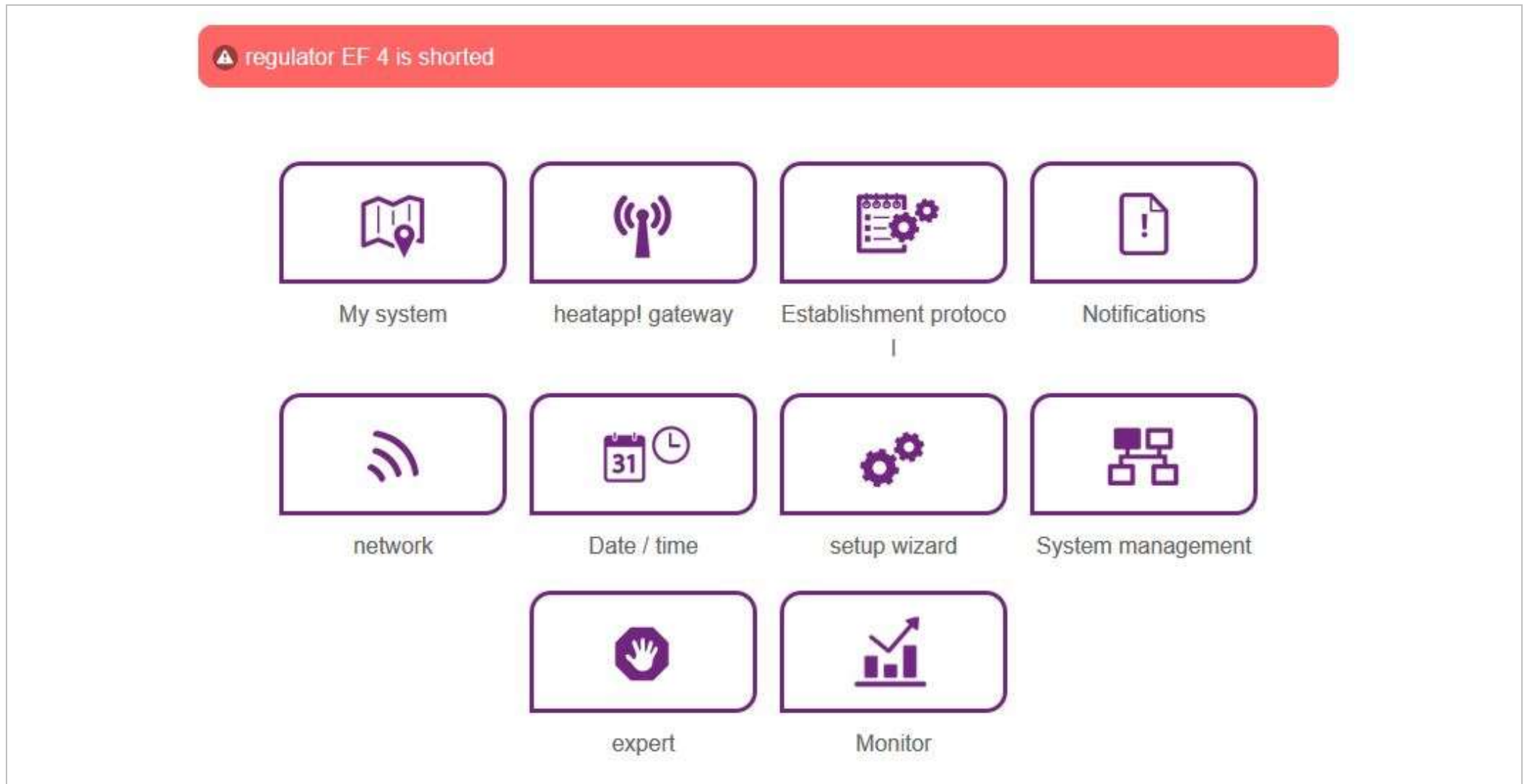

Fig. 65: Typical fault message on the PC user interface

Fault messages are displayed in the main menu on the PC user interface.

Error messages can also be sent as e-mail messages or push messages. Via the "Notification" button in the PC user interface or in the app in the system menu you can select the send message and the recipient.



Fig. 66: Button Notifications

## Mail notifications

Here you can specify e-mail addresses, to which error messages, notifications and other information is sent.

Admin Admin ▼

e-mail: Admin@online.de ✕

Add a new e-mail address

Save e-mail addresses

## User accounts

Here you can select users that should receive a push notification.

Admin Admin

Verwalter Verwalter

Save user accounts

Fig. 67: Notification

## 10.2 Fault messages of connected burner control systems

Menu	Parameter	Description
Expert / System /	Error code machine	<p>Selection of which fault messages of a machine are displayed and processed in the system (e.g. EO).</p> <ul style="list-style-type: none"><li>• <i>Off:</i> No fault messages of the burner control system are evaluated.</li><li>• <i>Locking:</i> Only locking of the burner control system is evaluated</li><li>• <i>Blocking:</i> Only locking and blocking of the burner control system is evaluated</li><li>• <i>Warning:</i> Locking, blocking and warnings of the burner control system are evaluated.</li></ul>

The *heatcon!* system offers the possibility of displaying and evaluating fault messages from a burner control system connected via a GEN bus (OpenTherm) in the *heatcon!* system. The fault messages can be filtered in three groups or completely deactivated.

### 10.3 heatcon! Error codes

Error code	Error number	Error-state	Disableable	Error location		Error type
W(n)-	GEN-spezifisch	System	Yes	Machine warning	GEN Adress 0 ... n	Warning message machine
B(n)-	GEN -spezifisch	System	Yes	Machine blocking	GEN Adress 0 ... n	Blocking message machine
E(n)-	GEN -spezifisch	System	Yes	Machine locking	GEN Adress 0 ... n	Locking message machine
4 ... 15	0	System	No	Sensor	Input E4 ... E15	Interruption
	1					Short circuit
1 ... 17	7	System	Yes	Faultmessage	Faultmessage input	Systemmessage (optional)
21 ... 24	0	System	No	Sensor	EM-1 Input E1 ... E4	Interruption
	1					Short circuit
31 ... 34	0	System	No	Sensor	EM-2 Input E1 ... E4	Interruption
	1					Short circuit
33	5	System	Yes	Energy generator	Emission control	Emission blocking
	6	System	Yes			Emission locking
49	4	Logisch	Yes	Energy generator 2		Setpoint temperature not reached
50	3	System	Yes	Energy generator		Start detection: GEN does not switch on
50	4	Logisch	Yes	Energy generator 1		Setpoint temperature not reached
51	4	Logisch	Yes	Domestic hot water		Setpoint temperature not reached
53 ... 76	5	Logisch	Yes	Room	Room 1 ... 24	Roomtemperature not reached
	15	System	No			Valve configured without sensor
	20	System	No			Heating supply not available
	21	System	No			Cooling supply not available
70	6	System	No	Bus	Machine	Fault connection to machine
70	1	System	No	EC		internal fault

Error code	Error number	Error-state	Disableable	Error location		Error type
70	9					
71	1					
71	6	System	No	Bus	EM-1	Fault connection to EM-1
72	6	System	No	Bus	EM-2	Fault connection to EM-2
81 ... 85	4	Logisch	Yes	Heating circuit	Heating circuit 1 ... 5	Setpoint temperature not reached
101 ... 124	1 ... 4	System	Yes	Room	Room 1 ... 24	Wireless valve 1 ... 4 Low battery
	9	System	Yes			Roomsensor Low battery
201 ... 224	1 ... 4	System	No	Room	Room 1 ... 24	Wireless valve 1 ... 4 no radio connection
	9					Roomsensor no radio connection

## 10.4 Fehlermeldungen

Error		Display MMI	Display App	Error description Code
Code	no.			
1	7		Controller EF 1 reports a malfunction	System message - fault message input active
4	0	<i>Display occurs according to the function assignment</i>	Controller EF 4 is interrupted	Eingang E4 (Fühler-) Interruption
4	1	<i>Display occurs according to the function assignment</i>	Controller EF 4 is short circuited	Input E4 (Sensor-)Short circuit
5	0	<i>Display occurs according to the function assignment</i>	Controller EF 5 is interrupted	Input E5 (Sensor-) Interruption
5	1	<i>Display occurs according to the function assignment</i>	Controller EF 5 is short circuited	Input E5 (Sensor-)Short circuit
6	0	<i>Display occurs according to the function assignment</i>	Controller EF 6 is interrupted	Input E6 (Sensor-) Interruption
6	1	<i>Display occurs according to the function assignment</i>	Controller EF 6 is short circuited	Input E6 (Sensor-)Short circuit
7	0	<i>Display occurs according to the function assignment</i>	Controller EF 7 is interrupted	Input E7 (Sensor-) Interruption
7	1	<i>Display occurs according to the function assignment</i>	Controller EF 7 is short circuited	Input E7 (Sensor-)Short circuit
8	0	<i>Display occurs according to the function assignment</i>	Controller EF 8 is interrupted	Input E8 (Sensor-) Interruption
8	1	<i>Display occurs according to the function assignment</i>	Controller EF 8 is short circuited	Input E8 (Sensor-)Short circuit
9	0	<i>Display occurs according to the function assignment</i>	Controller EF 9 is interrupted	Input E9 (Sensor-) Interruption
9	1	<i>Display occurs according to the function assignment</i>	Controller EF 9 is short circuited	Input E9 (Sensor-)Short circuit
10	0	<i>Display occurs according to the function assignment</i>	Controller EF 10 is interrupted	Input E10 (Sensor-) Interruption
10	1	<i>Display occurs according to the function assignment</i>	Controller EF 10 is short circuited	Input E10 (Sensor-)Short circuit



Error		Display MMI	Display App	Error description Code
Code	no.			
11	0	<i>Display occurs according to the function assignment</i>	Controller EF 11 is interrupted	Input E11 (Sensor-) Interruption
11	1	<i>Display occurs according to the function assignment</i>	Controller EF 11 is short circuited	Input E11 (Sensor-)Short circuit
12	0	<i>Display occurs according to the function assignment</i>	Controller EF 12 is interrupted	Input E12 (Sensor-) Interruption
12	1	<i>Display occurs according to the function assignment</i>	Controller EF 12 is short circuited	Input E12 (Sensor-)Short circuit
13	0	<i>Display occurs according to the function assignment</i>	Controller EF 13 is interrupted	Input E13 (Sensor-) Interruption
13	1	<i>Display occurs according to the function assignment</i>	Controller EF 13 is short circuited	Input E13 (Sensor-)Short circuit
14	0	<i>Display occurs according to the function assignment</i>	Controller EF 14 is interrupted	Input E14 (Sensor-) Interruption
14	1	<i>Display occurs according to the function assignment</i>	Controller EF 14 is short circuited	Input E14 (Sensor-)Short circuit
15	0	<i>Display occurs according to the function assignment</i>	Controller EF 15 is interrupted	Input E15 (Sensor-) Interruption
15	1	<i>Display occurs according to the function assignment</i>	Controller EF 15 is short circuited	Input E15 (Sensor-)Short circuit
21	0	<i>Display occurs according to the function assignment</i>	Extension module 1 EF 1 is interrupted	EM-1 Input E1 (Sensor-) Interruption
21	1	<i>Display occurs according to the function assignment</i>	Extension module 1 EF 1 is short circuited	EM-1 Input E1 (Sensor-)Short circuit
22	0	<i>Display occurs according to the function assignment</i>	Extension module 1 EF 2 is interrupted	EM-1 Input E2 (Sensor-) Interruption
22	1	<i>Display occurs according to the function assignment</i>	Extension module 1 EF 2 is short circuited	EM-1 Input E2 (Sensor-)Short circuit
23	0	<i>Display occurs according to the function assignment</i>	Extension module 1 EF 3 is interrupted	EM-1 Input E3 (Sensor-) Interruption

Error		Display MMI	Display App	Error description Code
Code	no.			
23	1	<i>Display occurs according to the function assignment</i>	Extension module 1 EF 3 is short circuited	EM-1 Input E3 (Sensor-)Short circuit
24	0	<i>Display occurs according to the function assignment</i>	Extension module 1 EF 4 is interrupted	EM-1 Input E4 (Sensor-) Interruption
24	1	<i>Display occurs according to the function assignment</i>	Extension module 1 EF 4 is short circuited	EM-1 Input E4 (Sensor-)Short circuit
31	0	<i>Display occurs according to the function assignment</i>	Extension module 2 EF 1 is interrupted	EM-2 Input E1 (Sensor-) Interruption
31	1	<i>Display occurs according to the function assignment</i>	Extension module 2 EF 1 is short circuited	EM-2 Input E1 (Sensor-)Short circuit
32	0	<i>Display occurs according to the function assignment</i>	Extension module 2 EF 2 is interrupted	EM-2 Input E2 (Sensor-) Interruption
32	1	<i>Display occurs according to the function assignment</i>	Extension module 2 EF 2 is short circuited	EM-2 Input E2 (Sensor-)Short circuit
33	0	<i>Display occurs according to the function assignment</i>	Extension module 2 EF 3 is interrupted	EM-2 Input E3 (Sensor-) Interruption
33	1	<i>Display occurs according to the function assignment</i>	Extension module 2 EF 3 is short circuited	EM-2 Input E3 (Sensor-)Short circuit
33	5	Energy generator	Energy generator Exhaust gas is in blocking	Exhaust gas monitoring - Exhaust gas bling
33	6	Energy generator	Energy generator Exhaust gas is in locking mode	Exhaust gas monitoring - Exhaust gas locking
34	0	<i>Display occurs according to the function assignment</i>	Extension module 2 EF 4 is interrupted	EM-2 Input E4 (Sensor-) Interruption
34	1	<i>Display occurs according to the function assignment</i>	Extension module 2 EF 4 is short circuited	EM-2 Input E4 (Sensor-)Short circuit
49	4	Energy generator	Energiererzeuger 2 Setpoint was not reached	GEN 2 Setpoint temperature not reached within 90 minutes

Error		Display MMI	Display App	Error description Code
Code	no.			
50	3	Energy generator	Energy generator does not switch on	GEN- Minimum temperature is not reached within the set starter detection
50	4	Energy generator	Energy generator 1 Setpoint was not reached	GEN 1 Setpoint temperature not reached within 90 minutes
51	4	Domestic hot water	Domestic hot water 1 Setpoint was not reached	Domestic hot water Setpoint temperature not reached within 240 minutes
53	5	Room 1	(Room 1/individual room name) Setpoint was not reached	Room-Setpoint temperature not reached within 180 minutes - Room 1
53	20	Room 1	(room 1/individually created room name) Supply Heating mode is not registered	Room supply is not available (deactivated)
53	21	Room 1	(Room 1/individually created room name) Supply Cooling mode is not registered	Room supply is not available (deactivated)
54	5	Room 2	(Room 2/individual room name) Setpoint was not reached	Room-Setpoint temperature not reached within 180 minutes - Room 2
54	20	Room 2	(room 2/individually created room name) Supply Heating mode is not registered	Room supply is not available (deactivated)
54	21	Room 2	(Room 2/individually created room name) Supply Cooling mode is not registered	Room supply is not available (deactivated)
55	5	Room 3	(Room 3/individual room name) Setpoint was not reached	Room-Setpoint temperature not reached within 180 minutes - Room 3
55	20	Room 3	(room 3/individually created room name) Supply Heating mode is not registered	Room supply is not available (deactivated)
55	21	Room 3	(Room 3/individually created room name) Supply Cooling mode is not registered	Room supply is not available (deactivated)
56	5	Room 4	(Room 4/individual room name) Setpoint was not reached	Room-Setpoint temperature not reached within 180 minutes - Room 4
56	20	Room 4	(Room 4/individually created Room name) Supply for heating operation is not registered	Room supply is not available (deactivated)
56	21	Room 4	(Room 4/individually created room name) Supply Cooling mode is not registered	Room supply is not available (deactivated)

Error		Display MMI	Display App	Error description Code
Code	no.			
57	5	Room 5	(Room 5/individual room name) Setpoint was not reached	Room-Setpoint temperature not reached within 180 minutes - Room 5
57	20	Room 5	(Room 5/individually created Room name) Supply for heating operation is not registered	Room supply is not available (deactivated)
57	21	Room 5	(Room 5/individually created room name) Supply Cooling mode is not registered	Room supply is not available (deactivated)
58	5	Room 6	(Room 6/individual room name) Setpoint was not reached	Room-Setpoint temperature not reached within 180 minutes - Room 6
58	20	Room 6	(Room 6/individually created Room name) Supply for heating operation is not registered	Room supply is not available (deactivated)
58	21	Room 6	(Room 6/individually created room name) Supply Cooling mode is not registered	Room supply is not available (deactivated)
59	5	Room 7	(Room 7/individual room name) Setpoint was not reached	Room-Setpoint temperature not reached within 180 minutes - Room 7
59	20	Room 7	(Room 7/individually created Room name) Supply for heating operation is not registered	Room supply is not available (deactivated)
59	21	Room 7	(Room 7/individually created room name) Supply Cooling mode is not registered	Room supply is not available (deactivated)
60	5	Room 8	(Room 8/individual room name) Setpoint was not reached	Room-Setpoint temperature not reached within 180 minutes - Room 8
60	20	Room 8	(Room 3/individually created Room name) Supply for heating operation is not registered	Room supply is not available (deactivated)
60	21	Room 8	(Room 8/individually created room name) Supply Cooling mode is not registered	Room supply is not available (deactivated)
61	5	Room 9	(Room 9/individual room name) Setpoint was not reached	Room-Setpoint temperature not reached within 180 minutes - Room 9
61	20	Room 9	(Room 9/individually created Room name) Supply for heating operation is not registered	Room supply is not available (deactivated)
61	21	Room 9	(Room 9/individually created room name) Supply Cooling mode is not registered	Room supply is not available (deactivated)

Error		Display MMI	Display App	Error description Code
Code	no.			
62	5	Room 10	(Room 10/individual room name) Setpoint was not reached	Room-Setpoint temperature not reached within 180 minutes - Room 10
62	20	Room 10	(Room 10/individually created Room name) Supply for heating operation is not registered	Room supply is not available (deactivated)
62	21	Room 10	(Room 10/individually created room name) Supply Cooling mode is not registered	Room supply is not available (deactivated)
63	5	Room 11	(Room 11/individual room name) Setpoint was not reached	Room-Setpoint temperature not reached within 180 minutes - Room 11
63	20	Room 11	(Room 11/individually created Room name) Supply for heating operation is not registered	Room supply is not available (deactivated)
63	21	Room 11	(Room 11/individually created room name) Supply Cooling mode is not registered	Room supply is not available (deactivated)
64	5	Room 12	(Room 12/individual room name) Setpoint was not reached	Room-Setpoint temperature not reached within 180 minutes - Room 12
64	20	Room 12	(Room 12/individually created Room name) Supply for heating operation is not registered	Room supply is not available (deactivated)
64	21	Room 12	(Room 12/individually created room name) Supply Cooling mode is not registered	Room supply is not available (deactivated)
65	5	Room 13	(Room 13/individual room name) Setpoint was not reached	Room-Setpoint temperature not reached within 180 minutes - Room 13
65	20	Room 13	(Room 13/individually created Room name) Supply for heating operation is not registered	Room supply is not available (deactivated)
65	21	Room 13	(Room 13/individually created room name) Supply Cooling mode is not registered	Room supply is not available (deactivated)
66	5	Room 14	(Room 14/individual room name) Setpoint was not reached	Room-Setpoint temperature not reached within 180 minutes - Room 14
66	20	Room 14	(Room 13/individually created Room name) Supply for heating operation is not registered	Room supply is not available (deactivated)
66	21	Room 14	(Room 14/individually created room name) Supply Cooling mode is not registered	Room supply is not available (deactivated)

Error		Display MMI	Display App	Error description Code
Code	no.			
67	5	Room 15	(Room 15/individual room name) Setpoint was not reached	Room-Setpoint temperature not reached within 180 minutes - Room 15
67	20	Room 15	(Room 15/individually created Room name) Supply for heating operation is not registered	Room supply is not available (deactivated)
67	21	Room 15	(Room 15/individually created room name) Supply Cooling mode is not registered	Room supply is not available (deactivated)
68	5	Room 16	(Room 16/individual room name) Setpoint was not reached	Room-Setpoint temperature not reached within 180 minutes - Room 16
68	20	Room 16	(Room 16/individually created Room name) Supply for heating operation is not registered	Room supply is not available (deactivated)
68	21	Room 16	(Room 16/individually created room name) Supply Cooling mode is not registered	Room supply is not available (deactivated)
69	5	Room 17	(Room 17/individual room name) Setpoint was not reached	Room-Setpoint temperature not reached within 180 minutes - Room 17
69	20	Room 17	(Room 17/individually created Room name) Supply for heating operation is not registered	Room supply is not available (deactivated)
69	21	Room 17	(Room 17/individually created room name) Supply Cooling mode is not registered	Room supply is not available (deactivated)
70	1	System	System	Internal error
70	5	Room 18	(Room 18/individual room name) Setpoint was not reached	Room-Setpoint temperature not reached within 180 minutes - Room 18
70	6	System	Energy generator 1 no data connection	Fault in the bus connection to the machine
			Energy generator 2 no data connection	
70	9	System	System	Internal error

Error		Display MMI	Display App	Error description Code
Code	no.			
70	20	Room 18	(Room 18/individually created Room name) Supply for heating operation is not registered	Room supply is not available (deactivated)
70	21	Room 18	(Room 18/individually created room name) Supply Cooling mode is not registered	Room supply is not available (deactivated)
71	1	System	System	Internal error
71	5	Room 19	(Room 19/individual room name) Setpoint was not reached	Room-Setpoint temperature not reached within 180 minutes - Room 19
71	6	System	Extension module 1 no data connection	Extension module 1 no data connection to the EC
71	20	Room 19	(Room 19/individually created Room name) Supply for heating operation is not registered	Room supply is not available (deactivated)
71	21	Room 19	(Room 19/individually created room name) Supply Cooling mode is not registered	Room supply is not available (deactivated)
72	5	Room 20	(Room 20/individual room name) Setpoint was not reached	Room-Setpoint temperature not reached within 180 minutes - Room 20
72	6	System	Extension module 2 no data connection	Extension module 2 no data connection to the EC
72	20	Room 20	(Room 20/individually created Room name) Supply for heating operation is not registered	Room supply is not available (deactivated)
72	21	Room 20	(Room 20/individually created room name) Supply Cooling mode is not registered	Room supply is not available (deactivated)
73	5	Room 21	(Room 21/individual room name) Setpoint was not reached	Room-Setpoint temperature not reached within 180 minutes - Room 21

Error		Display MMI	Display App	Error description Code
Code	no.			
73	20	Room 21	(Room 21/individually created Room name) Supply for heating operation is not registered	Room supply is not available (deactivated)
73	21	Room 21	(Room 21/individually created room name) Supply Cooling mode is not registered	Room supply is not available (deactivated)
74	5	Room 22	(Room 22/individual room name) Setpoint was not reached	Room-Setpoint temperature not reached within 180 minutes - Room 22
74	20	Room 22	(Room 22/individually created Room name) Supply for heating operation is not registered	Room supply is not available (deactivated)
74	21	Room 22	(Room 22/individually created room name) Supply Cooling mode is not registered	Room supply is not available (deactivated)
75	5	Room 23	(Room 23/individual room name) Setpoint was not reached	Room-Setpoint temperature not reached within 180 minutes - Room 23
75	20	Room 23	(Room 23/individually created Room name) Supply for heating operation is not registered	Room supply is not available (deactivated)
75	21	Room 23	(Room 23/individually created room name) Supply Cooling mode is not registered	Room supply is not available (deactivated)
76	5	Room 24	(Room 24/individual room name) Setpoint was not reached	Room-Setpoint temperature not reached within 180 minutes - Room 24
76	20	Room 24	(Room 23/individually created Room name) Supply for heating operation is not registered	Room supply is not available (deactivated)
76	21	Room 24	(Room 24/individually created room name) Supply Cooling mode is not registered	Room supply is not available (deactivated)
81	4	Heating circuit 1	Heating circuit 1 Setpoint was not reached	Heating circuit 1 Setpoint temperature not reached within 60 minutes
82	4	Heating circuit 2	Heating circuit 2 Setpoint was not reached	Heating circuit 2 Setpoint temperature not reached within 60 minutes



Error		Display MMI	Display App	Error description Code
Code	no.			
83	4	Heating circuit 3	Heating circuit 3 Setpoint was not reached	Heating circuit 3 Setpoint temperature not reached within 60 minutes
84	4	Heating circuit 4	Heating circuit 4 Setpoint was not reached	Heating circuit 4 Setpoint temperature not reached within 60 minutes
85	4	Heating circuit 5	Heating circuit 5 Setpoint was not reached	Heating circuit 5 Setpoint temperature not reached within 60 minutes
90	0	(individually created name)	Fault message input	Systemmessage – Fault message input active
101	1	Room 1	(Room 1/individual room name) Radio componente drive 1 reports Low battery	Low battery radio valve (heatapp! drive) 1 - Room 1
101	2	Room 1	(Room 1/individual room name) Radio componente drive 2 reports Low battery	Low battery radio valve (heatapp! drive) 2 - Room 1
101	3	Room 1	(Room 1/individual room name) Radio componente drive 3 reports Low battery	Low battery radio valve (heatapp! drive) 3 - Room 1
101	4	Room 1	(Room 1/individual room name) Radio componente drive 4 reports Low battery	Low battery radio valve (heatapp! drive) 4 - Room 1
101	9	Room 1	(Room 1/individual room name) heatapp! sense reports Low battery	Low battery Roomsensor (heatapp! sense) Room 1
102	1	Room 2	(Room 2/individual room name) Radio componente drive 1 reports Low battery	Low battery radio valve (heatapp! drive) 1 - Room 2
102	2	Room 2	(Room 2/individual room name) Radio componente drive 2 reports Low battery	Low battery radio valve (heatapp! drive) 2 - Room 2
102	3	Room 2	(Room 2/individual room name) Radio componente drive 3 reports Low battery	Low battery radio valve (heatapp! drive) 3 - Room 2
102	4	Room 2	(Room 2/individual room name) Radio componente drive 4 reports Low battery	Low battery radio valve (heatapp! drive) 4 - Room 2

Error		Display MMI	Display App	Error description Code
Code	no.			
102	9	Room 2	(Room 2/individual room name) heatapp! sense reports Low battery	Low battery Roomsensor (heatapp! sense) Room 2
103	1	Room 3	(Room 3/individual room name) Radio componente drive 1 reports Low battery	Low battery radio valve (heatapp! drive) 1 - Room 3
103	2	Room 3	(Room 3/individual room name) Radio componente drive 2 reports Low battery	Low battery radio valve (heatapp! drive) 2 - Room 3
103	3	Room 3	(Room 3/individual room name) Radio componente drive 3 reports Low battery	Low battery radio valve (heatapp! drive) 3 - Room 3
103	4	Room 3	(Room 3/individual room name) Radio componente drive 4 reports Low battery	Low battery radio valve (heatapp! drive) 4 - Room 3
103	9	Room 3	(Room 3/individual room name) heatapp! sense reports Low battery	Low battery Roomsensor (heatapp! sense) Room 3
104	1	Room 4	(Room 4/individual room name) Radio componente drive 1 reports Low battery	Low battery radio valve (heatapp! drive) 1 - Room 4
104	2	Room 4	(Room 4/individual room name) Radio componente drive 2 reports Low battery	Low battery radio valve (heatapp! drive) 2 - Room 4
104	3	Room 4	(Room 4/individual room name) Radio componente drive 3 reports Low battery	Low battery radio valve (heatapp! drive) 3 - Room 4
104	4	Room 4	(Room 4/individual room name) Radio componente drive 4 reports Low battery	Low battery radio valve (heatapp! drive) 4 - Room 4
104	9	Room 4	(Room 4/individual room name) heatapp! sense reports Low battery	Low battery Roomsensor (heatapp! sense) Room 4
105	1	Room 5	(Room 5/individual room name) Radio componente drive 1 reports Low battery	Low battery radio valve (heatapp! drive) 1 - Room 5
105	2	Room 5	(Room 5/individual room name) Radio componente drive 2 reports Low battery	Low battery radio valve (heatapp! drive) 2 - Room 5
105	3	Room 5	(Room 5/individual room name) Radio componente drive 3 reports Low battery	Low battery radio valve (heatapp! drive) 3 - Room 5

Error		Display MMI	Display App	Error description Code
Code	no.			
105	4	Room 5	(Room 5/individual room name) Radio componente drive 4 reports Low battery	Low battery radio valve (heatapp! drive) 4 - Room 5
105	9	Room 5	(Room 5/individual room name) heatapp! sense reports Low battery	Low battery Roomsensor (heatapp! sense) Room 5
106	1	Room 6	(Room 6/individual room name) Radio componente drive 1 reports Low battery	Low battery radio valve (heatapp! drive) 1 - Room 6
106	2	Room 6	(Room 6/individual room name) Radio componente drive 2 reports Low battery	Low battery radio valve (heatapp! drive) 2 - Room 6
106	3	Room 6	(Room 6/individual room name) Radio componente drive 3 reports Low battery	Low battery radio valve (heatapp! drive) 3 - Room 6
106	4	Room 6	(Room 6/individual room name) Radio componente drive 4 reports Low battery	Low battery radio valve (heatapp! drive) 4 - Room 6
106	9	Room 6	(Room 6/individual room name) heatapp! sense reports Low battery	Low battery Roomsensor (heatapp! sense) Room 6
107	1	Room 7	(Room 7/individual room name) Radio componente drive 1 reports Low battery	Low battery radio valve (heatapp! drive) 1 - Room 7
107	2	Room 7	(Room 7/individual room name) Radio componente drive 2 reports Low battery	Low battery radio valve (heatapp! drive) 2 - Room 7
107	3	Room 7	(Room 7/individual room name) Radio componente drive 3 reports Low battery	Low battery radio valve (heatapp! drive) 3 - Room 7
107	4	Room 7	(Room 7/individual room name) Radio componente drive 4 reports Low battery	Low battery radio valve (heatapp! drive) 4 - Room 7
107	9	Room 7	(Room 7/individual room name) heatapp! sense reports Low battery	Low battery Roomsensor (heatapp! sense) Room 7
108	1	Room 8	(Room 8/individual room name) Radio componente drive 1 reports Low battery	Low battery radio valve (heatapp! drive) 1 - Room 8
108	2	Room 8	(Room 8/individual room name) Radio componente drive 2 reports Low battery	Low battery radio valve (heatapp! drive) 2 - Room 8

Error		Display MMI	Display App	Error description Code
Code	no.			
108	3	Room 8	(Room 8/individual room name) Radio componente drive 3 reports Low battery	Low battery radio valve (heatapp! drive) 3 - Room 8
108	4	Room 8	(Room 8/individual room name) Radio componente drive 4 reports Low battery	Low battery radio valve (heatapp! drive) 4 - Room 8
108	9	Room 8	(Room 8/individual room name) heatapp! sense reports Low battery	Low battery Roomsensor (heatapp! sense) Room 8
109	1	Room 9	(Room 9/individual room name) Radio componente drive 1 reports Low battery	Low battery radio valve (heatapp! drive) 1 - Room 9
109	2	Room 9	(Room 9/individual room name) Radio componente drive 2 reports Low battery	Low battery radio valve (heatapp! drive) 2 - Room 9
109	3	Room 9	(Room 9/individual room name) Radio componente drive 3 reports Low battery	Low battery radio valve (heatapp! drive) 3 - Room 9
109	4	Room 9	(Room 9/individual room name) Radio componente drive 4 reports Low battery	Low battery radio valve (heatapp! drive) 4 - Room 9
109	9	Room 9	(Room 9/individual room name) heatapp! sense reports Low battery	Low battery Roomsensor (heatapp! sense) Room 9
110	1	Room 10	(Room 10/individual room name) Radio componente drive 1 reports Low battery	Low battery radio valve (heatapp! drive) 1 - Room 10
110	2	Room 10	(Room 10/individual room name) Radio componente drive 2 reports Low battery	Low battery radio valve (heatapp! drive) 2 - Room 10
110	3	Room 10	(Room 10/individual room name) Radio componente drive 3 reports Low battery	Low battery radio valve (heatapp! drive) 3 - Room 10
110	4	Room 10	(Room 10/individual room name) Radio componente drive 4 reports Low battery	Low battery radio valve (heatapp! drive) 4 - Room 10
110	9	Room 10	(Room 10/individual room name) heatapp! sense reports Low battery	Low battery Roomsensor (heatapp! sense) Room 10
111	1	Room 11	(Room 11/individual room name) Radio componente drive 1 reports Low battery	Low battery radio valve (heatapp! drive) 1 - Room 11

Error		Display MMI	Display App	Error description Code
Code	no.			
111	2	Room 11	(Room 11/individual room name) Radio componente drive 2 reports Low battery	Low battery radio valve (heatapp! drive) 2 - Room 11
111	3	Room 11	(Room 11/individual room name) Radio componente drive 3 reports Low battery	Low battery radio valve (heatapp! drive) 3 - Room 11
111	4	Room 11	(Room 11/individual room name) Radio componente drive 4 reports Low battery	Low battery radio valve (heatapp! drive) 4 - Room 11
111	9	Room 11	(Room 11/individual room name) heatapp! sense reports Low battery	Low battery Roomsensor (heatapp! sense) Room 11
112	1	Room 12	(Room 12/individual room name) Radio componente drive 1 reports Low battery	Low battery radio valve (heatapp! drive) 1 - Room 12
112	2	Room 12	(Room 12/individual room name) Radio componente drive 2 reports Low battery	Low battery radio valve (heatapp! drive) 2 - Room 12
112	3	Room 12	(Room 12/individual room name) Radio componente drive 3 reports Low battery	Low battery radio valve (heatapp! drive) 3 - Room 12
112	4	Room 12	(Room 12/individual room name) Radio componente drive 4 reports Low battery	Low battery radio valve (heatapp! drive) 4 - Room 12
112	9	Room 12	(Room 12/individual room name) heatapp! sense reports Low battery	Low battery Roomsensor (heatapp! sense) Room 12
113	1	Room 13	(Room 13/individual room name) Radio componente drive 1 reports Low battery	Low battery radio valve (heatapp! drive) 1 - Room 13
113	2	Room 13	(Room 13/individual room name) Radio componente drive 2 reports Low battery	Low battery radio valve (heatapp! drive) 2 - Room 13
113	3	Room 13	(Room 13/individual room name) Radio componente drive 3 reports Low battery	Low battery radio valve (heatapp! drive) 3 - Room 13
113	4	Room 13	(Room 13/individual room name) Radio componente drive 4 reports Low battery	Low battery radio valve (heatapp! drive) 4 - Room 13
113	9	Room 13	(Room 13/individual room name) heatapp! sense reports Low battery	Low battery Roomsensor (heatapp! sense) Room 13

Error		Display MMI	Display App	Error description Code
Code	no.			
114	1	Room 14	(Room 14/individual room name) Radio componente drive 1 reports Low battery	Low battery radio valve (heatapp! drive) 1 - Room 14
114	2	Room 14	(Room 14/individual room name) Radio componente drive 2 reports Low battery	Low battery radio valve (heatapp! drive) 2 - Room 14
114	3	Room 14	(Room 14/individual room name) Radio componente drive 3 reports Low battery	Low battery radio valve (heatapp! drive) 3 - Room 14
114	4	Room 14	(Room 14/individual room name) Radio componente drive 4 reports Low battery	Low battery radio valve (heatapp! drive) 4 - Room 14
114	9	Room 14	(Room 14/individual room name) heatapp! sense reports Low battery	Low battery Roomsensor (heatapp! sense) Room 14
115	1	Room 15	(Room 15/individual room name) Radio componente drive 1 reports Low battery	Low battery radio valve (heatapp! drive) 1 - Room 15
115	2	Room 15	(Room 15/individual room name) Radio componente drive 2 reports Low battery	Low battery radio valve (heatapp! drive) 2 - Room 15
115	3	Room 15	(Room 15/individual room name) Radio componente drive 3 reports Low battery	Low battery radio valve (heatapp! drive) 3 - Room 15
115	4	Room 15	(Room 15/individual room name) Radio componente drive 4 reports Low battery	Low battery radio valve (heatapp! drive) 4 - Room 15
115	9	Room 15	(Room 15/individual room name) heatapp! sense reports Low battery	Low battery Roomsensor (heatapp! sense) Room 15
116	1	Room 16	(Room 16/individual room name) Radio componente drive 1 reports Low battery	Low battery radio valve (heatapp! drive) 1 - Room 16
116	2	Room 16	(Room 16/individual room name) Radio componente drive 2 reports Low battery	Low battery radio valve (heatapp! drive) 2 - Room 16
116	3	Room 16	(Room 16/individual room name) Radio componente drive 3 reports Low battery	Low battery radio valve (heatapp! drive) 3 - Room 16
116	4	Room 16	(Room 16/individual room name) Radio componente drive 4 reports Low battery	Low battery radio valve (heatapp! drive) 4 - Room 16

Error		Display MMI	Display App	Error description Code
Code	no.			
116	9	Room 16	(Room 16/individual room name) heatapp! sense reports Low battery	Low battery Roomsensor (heatapp! sense) Room 16
117	1	Room 17	(Room 17/individual room name) Radio componente drive 1 reports Low battery	Low battery radio valve (heatapp! drive) 1 - Room 17
117	2	Room 17	(Room 17/individual room name) Radio componente drive 2 reports Low battery	Low battery radio valve (heatapp! drive) 2 - Room 17
117	3	Room 17	(Room 17/individual room name) Radio componente drive 3 reports Low battery	Low battery radio valve (heatapp! drive) 3 - Room 17
117	4	Room 17	(Room 17/individual room name) Radio componente drive 4 reports Low battery	Low battery radio valve (heatapp! drive) 4 - Room 17
117	9	Room 17	(Room 17/individual room name) heatapp! sense reports Low battery	Low battery Roomsensor (heatapp! sense) Room 17
118	1	Room 18	(Room 18/individual room name) Radio componente drive 1 reports Low battery	Low battery radio valve (heatapp! drive) 1 - Room 18
118	2	Room 18	(Room 18/individual room name) Radio componente drive 2 reports Low battery	Low battery radio valve (heatapp! drive) 2 - Room 18
118	3	Room 18	(Room 18/individual room name) Radio componente drive 3 reports Low battery	Low battery radio valve (heatapp! drive) 3 - Room 18
118	4	Room 18	(Room 18/individual room name) Radio componente drive 4 reports Low battery	Low battery radio valve (heatapp! drive) 4 - Room 18
118	9	Room 18	(Room 18/individual room name) heatapp! sense reports Low battery	Low battery Roomsensor (heatapp! sense) Room 18
119	1	Room 19	(Room 19/individual room name) Radio componente drive 1 reports Low battery	Low battery radio valve (heatapp! drive) 1 - Room 19
119	2	Room 19	(Room 19/individual room name) Radio componente drive 2 reports Low battery	Low battery radio valve (heatapp! drive) 2 - Room 19
119	3	Room 19	(Room 19/individual room name) Radio componente drive 3 reports Low battery	Low battery radio valve (heatapp! drive) 3 - Room 19

Error		Display MMI	Display App	Error description Code
Code	no.			
119	4	Room 19	(Room 19/individual room name) Radio componente drive 4 reports Low battery	Low battery radio valve (heatapp! drive) 4 - Room 19
119	9	Room 19	(Room 19/individual room name) heatapp! sense reports Low battery	Low battery Roomsensor (heatapp! sense) Room 19
120	1	Room 20	(Room 20/individual room name) Radio componente drive 1 reports Low battery	Low battery radio valve (heatapp! drive) 1 - Room 20
120	2	Room 20	(Room 20/individual room name) Radio componente drive 2 reports Low battery	Low battery radio valve (heatapp! drive) 2 - Room 20
120	3	Room 20	(Room 20/individual room name) Radio componente drive 3 reports Low battery	Low battery radio valve (heatapp! drive) 3 - Room 20
120	4	Room 20	(Room 20/individual room name) Radio componente drive 4 reports Low battery	Low battery radio valve (heatapp! drive) 4 - Room 20
120	9	Room 20	(Room 20/individual room name) heatapp! sense reports Low battery	Low battery Roomsensor (heatapp! sense) Room 20
121	1	Room 21	(Room 21/individual room name) Radio componente drive 1 reports Low battery	Low battery radio valve (heatapp! drive) 1 - Room 21
121	2	Room 21	(Room 21/individual room name) Radio componente drive 2 reports Low battery	Low battery radio valve (heatapp! drive) 2 - Room 21
121	3	Room 21	(Room 21/individual room name) Radio componente drive 3 reports Low battery	Low battery radio valve (heatapp! drive) 3 - Room 21
121	4	Room 21	(Room 21/individual room name) Radio componente drive 4 reports Low battery	Low battery radio valve (heatapp! drive) 4 - Room 21
121	9	Room 21	(Room 21/individual room name) heatapp! sense reports Low battery	Low battery Roomsensor (heatapp! sense) Room 21
122	1	Room 22	(Room 22/individual room name) Radio componente drive 1 reports Low battery	Low battery radio valve (heatapp! drive) 1 - Room 22
122	2	Room 22	(Room 22/individual room name) Radio componente drive 2 reports Low battery	Low battery radio valve (heatapp! drive) 2 - Room 22



Error		Display MMI	Display App	Error description Code
Code	no.			
122	3	Room 22	(Room 22/individual room name) Radio componente drive 3 reports Low battery	Low battery radio valve (heatapp! drive) 3 - Room 22
122	4	Room 22	(Room 22/individual room name) Radio componente drive 4 reports Low battery	Low battery radio valve (heatapp! drive) 4 - Room 22
122	9	Room 22	(Room 22/individual room name) heatapp! sense reports Low battery	Low battery Roomsensor (heatapp! sense) Room 22
123	1	Room 23	(Room 23/individual room name) Radio componente drive 1 reports Low battery	Low battery radio valve (heatapp! drive) 1 - Room 23
123	2	Room 23	(Room 23/individual room name) Radio componente drive 2 reports Low battery	Low battery radio valve (heatapp! drive) 2 - Room 23
123	3	Room 23	(Room 23/individual room name) Radio componente drive 3 reports Low battery	Low battery radio valve (heatapp! drive) 3 - Room 23
123	4	Room 23	(Room 23/individual room name) Radio componente drive 4 reports Low battery	Low battery radio valve (heatapp! drive) 4 - Room 23
123	9	Room 23	(Room 23/individual room name) heatapp! sense reports Low battery	Low battery Roomsensor (heatapp! sense) Room 23
124	1	Room 24	(Room 24/individual room name) Radio componente drive 1 reports Low battery	Low battery radio valve (heatapp! drive) 1 - Room 24
124	2	Room 24	(Room 24/individual room name) Radio componente drive 2 reports Low battery	Low battery radio valve (heatapp! drive) 2 - Room 24
124	3	Room 24	(Room 24/individual room name) Radio componente drive 3 reports Low battery	Low battery radio valve (heatapp! drive) 3 - Room 24
124	4	Room 24	(Room 24/individual room name) Radio componente drive 4 reports Low battery	Low battery radio valve (heatapp! drive) 4 - Room 24
124	9	Room 24	(Room 24/individual room name) heatapp! sense reports Low battery	Low battery Roomsensor (heatapp! sense) Room 24

Error		Display MMI	Display App	Error description Code
Code	no.			
201	1	Room 1	(Room 1/individual room name) Radio componente drive does not respond	No radio connection radio valve (heatapp! drive) 1 - Room 1
201	2	Room 1	(Room 1/individual room name) Radio componente drive does not respond	No radio connection radio valve (heatapp! drive) 2 - Room 1
201	3	Room 1	(Room 1/individual room name) Radio componente drive does not respond	No radio connection radio valve (heatapp! drive) 3 - Room 1
201	4	Room 1	(Room 1/individual room name) Radio componente drive does not respond	No radio connection radio valve (heatapp! drive) 4 - Room 1
201	9	Room 1	(Room 1/individual room name) heatapp! sense does not respond	No radio connection Roomsensor (heatapp! sense) - Room 1
202	1	Room 2	(Room 2/individual room name) Radio componente drive does not respond	No radio connection radio valve (heatapp! drive) 1 - Room 2
202	2	Room 2	(Room 2/individual room name) Radio componente drive does not respond	No radio connection radio valve (heatapp! drive) 2 - Room 2
202	3	Room 2	(Room 2/individual room name) Radio componente drive does not respond	No radio connection radio valve (heatapp! drive) 3 - Room 2
202	4	Room 2	(Room 2/individual room name) Radio componente drive does not respond	No radio connection radio valve (heatapp! drive) 4 - Room 2
202	9	Room 2	(Room 2/individual room name) heatapp! sense does not respond	No radio connection Roomsensor (heatapp! sense) - Room 2
203	1	Room 3	(Room 3/individual room name) Radio componente drive does not respond	No radio connection radio valve (heatapp! drive) 1 - Room 3
203	2	Room 3	(Room 3/individual room name) Radio componente drive does not respond	No radio connection radio valve (heatapp! drive) 2 - Room 3
203	3	Room 3	(Room 3/individual room name) Radio componente drive does not respond	No radio connection radio valve (heatapp! drive) 3 - Room 3
203	4	Room 3	(Room 3/individual room name) Radio componente drive does not respond	No radio connection radio valve (heatapp! drive) 4 - Room 3

Error		Display MMI	Display App	Error description Code
Code	no.			
203	9	Room 3	(Room 3/individual room name) heatapp! sense does not respond	No radio connection Roomsensor (heatapp! sense) - Room 3
204	1	Room 4	(Room 4/individual room name) Radio componente drive does not respond	No radio connection radio valve (heatapp! drive) 1 - Room 4
204	2	Room 4	(Room 4/individual room name) Radio componente drive does not respond	No radio connection radio valve (heatapp! drive) 2 - Room 4
204	3	Room 4	(Room 4/individual room name) Radio componente drive does not respond	No radio connection radio valve (heatapp! drive) 3 - Room 4
204	4	Room 4	(Room 4/individual room name) Radio componente drive does not respond	No radio connection radio valve (heatapp! drive) 4 - Room 4
204	9	Room 4	(Room 4/individual room name) heatapp! sense does not respond	No radio connection Roomsensor (heatapp! sense) - Room 4
205	1	Room 5	(Room 5/individual room name) Radio componente drive does not respond	No radio connection radio valve (heatapp! drive) 1 - Room 5
205	2	Room 5	(Room 5/individual room name) Radio componente drive does not respond	No radio connection radio valve (heatapp! drive) 2 - Room 5
205	3	Room 5	(Room 5/individual room name) Radio componente drive does not respond	No radio connection radio valve (heatapp! drive) 3 - Room 5
205	4	Room 5	(Room 5/individual room name) Radio componente drive does not respond	No radio connection radio valve (heatapp! drive) 4 - Room 5
205	9	Room 5	(Room 5/individual room name) heatapp! sense does not respond	No radio connection Roomsensor (heatapp! sense) - Room 5
206	1	Room 6	(Room 6/individual room name) Radio componente drive does not respond	No radio connection radio valve (heatapp! drive) 1 - Room 6
206	2	Room 6	(Room 6/individual room name) Radio componente drive does not respond	No radio connection radio valve (heatapp! drive) 2 - Room 6
206	3	Room 6	(Room 6/individual room name) Radio componente drive does not respond	No radio connection radio valve (heatapp! drive) 3 - Room 6

Error		Display MMI	Display App	Error description Code
Code	no.			
206	4	Room 6	(Room 6/individual room name) Radio componente drive does not respond	No radio connection radio valve (heatapp! drive) 4 - Room 6
206	9	Room 6	(Room 6/individual room name) heatapp! sense does not respond	No radio connection Roomsensor (heatapp! sense) - Room 6
207	1	Room 7	(Room 7/individual room name) Radio componente drive does not respond	No radio connection radio valve (heatapp! drive) 1 - Room 7
207	2	Room 7	(Room 7/individual room name) Radio componente drive does not respond	No radio connection radio valve (heatapp! drive) 2 - Room 7
207	3	Room 7	(Room 7/individual room name) Radio componente drive does not respond	No radio connection radio valve (heatapp! drive) 3 - Room 7
207	4	Room 7	(Room 7/individual room name) Radio componente drive does not respond	No radio connection radio valve (heatapp! drive) 4 - Room 7
207	9	Room 7	(Room 7/individual room name) heatapp! sense does not respond	No radio connection Roomsensor (heatapp! sense) - Room 7
208	1	Room 8	(Room 8/individual room name) Radio componente drive does not respond	No radio connection radio valve (heatapp! drive) 1 - Room 8
208	2	Room 8	(Room 8/individual room name) Radio componente drive does not respond	No radio connection radio valve (heatapp! drive) 2 - Room 8
208	3	Room 8	(Room 8/individual room name) Radio componente drive does not respond	No radio connection radio valve (heatapp! drive) 3 - Room 8
208	4	Room 8	(Room 8/individual room name) Radio componente drive does not respond	No radio connection radio valve (heatapp! drive) 4 - Room 8
208	9	Room 8	(Room 8/individual room name) heatapp! sense does not respond	No radio connection Roomsensor (heatapp! sense) - Room 8
209	1	Room 9	(Room 9/individual room name) Radio componente drive does not respond	No radio connection radio valve (heatapp! drive) 1 - Room 9
209	2	Room 9	(Room 9/individual room name) Radio componente drive does not respond	No radio connection radio valve (heatapp! drive) 2 - Room 9

Error		Display MMI	Display App	Error description Code
Code	no.			
209	3	Room 9	(Room 9/individual room name) Radio componente drive does not respond	No radio connection radio valve (heatapp! drive) 3 - Room 9
209	4	Room 9	(Room 9/individual room name) Radio componente drive does not respond	No radio connection radio valve (heatapp! drive) 4 - Room 9
209	9	Room 9	(Room 9/individual room name) heatapp! sense does not respond	No radio connection Roomsensor (heatapp! sense) - Room 9
210	1	Room 10	(Room 10/individual room name) Radio componente drive does not respond	No radio connection radio valve (heatapp! drive) 1 - Room 10
210	2	Room 10	(Room 10/individual room name) Radio componente drive does not respond	No radio connection radio valve (heatapp! drive) 2 - Room 10
210	3	Room 10	(Room 10/individual room name) Radio componente drive does not respond	No radio connection radio valve (heatapp! drive) 3 - Room 10
210	4	Room 10	(Room 10/individual room name) Radio componente drive does not respond	No radio connection radio valve (heatapp! drive) 4 - Room 10
210	9	Room 10	(Room 10/individual room name) heatapp! sense does not respond	No radio connection Roomsensor (heatapp! sense) - Room 10
211	1	Room 11	(Room 11/individual room name) Radio componente drive does not respond	No radio connection radio valve (heatapp! drive) 1 - Room 11
211	2	Room 11	(Room 11/individual room name) Radio componente drive does not respond	No radio connection radio valve (heatapp! drive) 2 - Room 11
211	3	Room 11	(Room 11/individual room name) Radio componente drive does not respond	No radio connection radio valve (heatapp! drive) 3 - Room 11
211	4	Room 11	(Room 11/individual room name) Radio componente drive does not respond	No radio connection radio valve (heatapp! drive) 4 - Room 11
211	9	Room 11	(Room 11/individual room name) heatapp! sense does not respond	No radio connection Roomsensor (heatapp! sense) - Room 11
212	1	Room 12	(Room 12/individual room name) Radio componente drive does not respond	No radio connection radio valve (heatapp! drive) 1 - Room 12

Error		Display MMI	Display App	Error description Code
Code	no.			
212	2	Room 12	(Room 12/individual room name) Radio componente drive does not respond	No radio connection radio valve (heatapp! drive) 2 - Room 12
212	3	Room 12	(Room 12/individual room name) Radio componente drive does not respond	No radio connection radio valve (heatapp! drive) 3 - Room 12
212	4	Room 12	(Room 12/individual room name) Radio componente drive does not respond	No radio connection radio valve (heatapp! drive) 4 - Room 12
212	9	Room 12	(Room 12/individual room name) heatapp! sense does not respond	No radio connection Roomsensor (heatapp! sense) - Room 12
213	1	Room 13	(Room 13/individual room name) Radio componente drive does not respond	No radio connection radio valve (heatapp! drive) 1 - Room 13
213	2	Room 13	(Room 13/individual room name) Radio componente drive does not respond	No radio connection radio valve (heatapp! drive) 2 - Room 13
213	3	Room 13	(Room 13/individual room name) Radio componente drive does not respond	No radio connection radio valve (heatapp! drive) 3 - Room 13
213	4	Room 13	(Room 13/individual room name) Radio componente drive does not respond	No radio connection radio valve (heatapp! drive) 4 - Room 13
213	9	Room 13	(Room 13/individual room name) heatapp! sense does not respond	No radio connection Roomsensor (heatapp! sense) - Room 13
214	1	Room 14	(Room 14/individual room name) Radio componente drive does not respond	No radio connection radio valve (heatapp! drive) 1 - Room 14
214	2	Room 14	(Room 14/individual room name) Radio componente drive does not respond	No radio connection radio valve (heatapp! drive) 2 - Room 14
214	3	Room 14	(Room 14/individual room name) Radio componente drive does not respond	No radio connection radio valve (heatapp! drive) 3 - Room 14
214	4	Room 14	(Room 14/individual room name) Radio componente drive does not respond	No radio connection radio valve (heatapp! drive) 4 - Room 14
214	9	Room 14	(Room 14/individual room name) heatapp! sense does not respond	No radio connection Roomsensor (heatapp! sense) - Room 14

Error		Display MMI	Display App	Error description Code
Code	no.			
215	1	Room 15	(Room 15/individual room name) Radio componente drive does not respond	No radio connection radio valve (heatapp! drive) 1 - Room 15
215	2	Room 15	(Room 15/individual room name) Radio componente drive does not respond	No radio connection radio valve (heatapp! drive) 2 - Room 15
215	3	Room 15	(Room 15/individual room name) Radio componente drive does not respond	No radio connection radio valve (heatapp! drive) 3 - Room 15
215	4	Room 15	(Room 15/individual room name) Radio componente drive does not respond	No radio connection radio valve (heatapp! drive) 4 - Room 15
215	9	Room 15	(Room 15/individual room name) heatapp! sense does not respond	No radio connection Roomsensor (heatapp! sense) - Room 15
216	1	Room 16	(Room 16/individual room name) Radio componente drive does not respond	No radio connection radio valve (heatapp! drive) 1 - Room 16
216	2	Room 16	(Room 16/individual room name) Radio componente drive does not respond	No radio connection radio valve (heatapp! drive) 2 - Room 16
216	3	Room 16	(Room 16/individual room name) Radio componente drive does not respond	No radio connection radio valve (heatapp! drive) 3 - Room 16
216	4	Room 16	(Room 16/individual room name) Radio componente drive does not respond	No radio connection radio valve (heatapp! drive) 4 - Room 16
216	9	Room 16	(Room 16/individual room name) heatapp! sense does not respond	No radio connection Roomsensor (heatapp! sense) - Room 16
217	1	Room 17	(Room 17/individual room name) Radio componente drive does not respond	No radio connection radio valve (heatapp! drive) 1 - Room 17
217	2	Room 17	(Room 17/individual room name) Radio componente drive does not respond	No radio connection radio valve (heatapp! drive) 2 - Room 17
217	3	Room 17	(Room 17/individual room name) Radio componente drive does not respond	No radio connection radio valve (heatapp! drive) 3 - Room 17
217	4	Room 17	(Room 17/individual room name) Radio componente drive does not respond	No radio connection radio valve (heatapp! drive) 4 - Room 17

Error		Display MMI	Display App	Error description Code
Code	no.			
217	9	Room 17	(Room 17/individual room name) heatapp! sense does not respond	No radio connection Roomsensor (heatapp! sense) - Room 17
218	1	Room 18	(Room 18/individual room name) Radio componente drive does not respond	No radio connection radio valve (heatapp! drive) 1 - Room 18
218	2	Room 18	(Room 18/individual room name) Radio componente drive does not respond	No radio connection radio valve (heatapp! drive) 2 - Room 18
218	3	Room 18	(Room 18/individual room name) Radio componente drive does not respond	No radio connection radio valve (heatapp! drive) 3 - Room 18
218	4	Room 18	(Room 18/individual room name) Radio componente drive does not respond	No radio connection radio valve (heatapp! drive) 4 - Room 18
218	9	Room 18	(Room 18/individual room name) heatapp! sense does not respond	No radio connection Roomsensor (heatapp! sense) - Room 18
219	1	Room 19	(Room 19/individual room name) Radio componente drive does not respond	No radio connection radio valve (heatapp! drive) 1 - Room 19
219	2	Room 19	(Room 19/individual room name) Radio componente drive does not respond	No radio connection radio valve (heatapp! drive) 2 - Room 19
219	3	Room 19	(Room 19/individual room name) Radio componente drive does not respond	No radio connection radio valve (heatapp! drive) 3 - Room 19
219	4	Room 19	(Room 19/individual room name) Radio componente drive does not respond	No radio connection radio valve (heatapp! drive) 4 - Room 19
219	9	Room 19	(Room 19/individual room name) heatapp! sense does not respond	No radio connection Roomsensor (heatapp! sense) - Room 19
220	1	Room 20	(Room 20/individual room name) Radio componente drive does not respond	No radio connection radio valve (heatapp! drive) 1 - Room 20
220	2	Room 20	(Room 20/individual room name) Radio componente drive does not respond	No radio connection radio valve (heatapp! drive) 2 - Room 20
220	3	Room 20	(Room 20/individual room name) Radio componente drive does not respond	No radio connection radio valve (heatapp! drive) 3 - Room 20



Error		Display MMI	Display App	Error description Code
Code	no.			
220	4	Room 20	(Room 20/individual room name) Radio componente drive does not respond	No radio connection radio valve (heatapp! drive) 4 - Room 20
220	9	Room 20	(Room 20/individual room name) heatapp! sense does not respond	No radio connection Roomsensor (heatapp! sense) - Room 20
221	1	Room 21	(Room 21/individual room name) Radio componente drive does not respond	No radio connection radio valve (heatapp! drive) 1 - Room 21
221	2	Room 21	(Room 21/individual room name) Radio componente drive does not respond	No radio connection radio valve (heatapp! drive) 2 - Room 21
221	3	Room 21	(Room 21/individual room name) Radio componente drive does not respond	No radio connection radio valve (heatapp! drive) 3 - Room 21
221	4	Room 21	(Room 21/individual room name) Radio componente drive does not respond	No radio connection radio valve (heatapp! drive) 4 - Room 21
221	9	Room 21	(Room 21/individual room name) heatapp! sense does not respond	No radio connection Roomsensor (heatapp! sense) - Room 21
222	1	Room 22	(Room 22/individual room name) Radio componente drive does not respond	No radio connection radio valve (heatapp! drive) 1 - Room 22
222	2	Room 22	(Room 22/individual room name) Radio componente drive does not respond	No radio connection radio valve (heatapp! drive) 2 - Room 22
222	3	Room 22	(Room 22/individual room name) Radio componente drive does not respond	No radio connection radio valve (heatapp! drive) 3 - Room 22
222	4	Room 22	(Room 22/individual room name) Radio componente drive does not respond	No radio connection radio valve (heatapp! drive) 4 - Room 22
222	9	Room 22	(Room 22/individual room name) heatapp! sense does not respond	No radio connection Roomsensor (heatapp! sense) - Room 22
223	1	Room 23	(Room 23/individual room name) Radio componente drive does not respond	No radio connection radio valve (heatapp! drive) 1 - Room 23
223	2	Room 23	(Room 23/individual room name) Radio componente drive does not respond	No radio connection radio valve (heatapp! drive) 2 - Room 23

Error		Display MMI	Display App	Error description Code
Code	no.			
223	3	Room 23	(Room 23/individual room name) Radio componente drive does not respond	No radio connection radio valve (heatapp! drive) 3 - Room 23
223	4	Room 23	(Room 23/individual room name) Radio componente drive does not respond	No radio connection radio valve (heatapp! drive) 4 - Room 23
223	9	Room 23	(Room 23/individual room name) heatapp! sense does not respond	No radio connection Roomsensor (heatapp! sense) - Room 23
224	1	Room 24	(Room 24/individual room name) Radio componente drive does not respond	No radio connection radio valve (heatapp! drive) 1 - Room 24
224	2	Room 24	(Room 24/individual room name) Radio componente drive does not respond	No radio connection radio valve (heatapp! drive) 2 - Room 24
224	3	Room 24	(Room 24/individual room name) Radio componente drive does not respond	No radio connection radio valve (heatapp! drive) 3 - Room 24
224	4	Room 24	(Room 24/individual room name) Radio componente drive does not respond	No radio connection radio valve (heatapp! drive) 4 - Room 24
224	9	Room 24	(Room 24/individual room name) heatapp! sense does not respond	No radio connection Roomsensor (heatapp! sense) - Room 24

## 11 Accessories

The accessories listed below are available for the *heatcon!* system.

### 11.1 Outside sensor Outside temperature



Fig. 68: Outside sensor Outside temperature

Outside sensor for measuring the outside temperature at the building.

The measured outside temperature is indicated in the *heatapp!* app.

The measured outside temperature can also be used to switch off the heating above a certain outside temperature.

Sensor type	Measuring range
KTY	-50 ... 90 °C

## 11.2 Immersion sensor KVT



Fig. 69: Immersion sensor KVT

Immersion sensor, e.g. for use as an energy generator sensor, hot water sensor (with integrated DHW storages), return flow sensor, etc.

The immersion sensor is available in two versions:

- KVT 20/2/6: 2 m cable length
- KVT 20/5/6: 5 m cable length

Sensor type	Measuring range
KTY	-50 ... 120 °C

### 11.3 Immersion sensor PT1000



Fig. 70: Immersion sensor PT1000

Immersion sensor with increased temperature measuring range, e.g. for use as an exhOfft gas sensor or solar collector sensor.

Versions:

- PT1000/6: 2.5 m cable length

Sensor type	Measuring range
PT1000	-50 ... 500 °C

## 11.4 Flow sensor VF



G0031

Fig. 71: Flow sensor VF

Contact sensor, e.g. for measuring the heating flow or return temperature in mixer-controlled heating circuits.

The contact sensor is available in two versions:

- VF 202: 2 m cable length
- VF 204: 4 m cable length

Sensor type	Measuring range
KTY	-50 ... 120 °C

## 11.5 heatcon! Sensor-Set

The heatcon! sensor set can be purchased as an accessory. It contains the following sensors:

- 1x outdoor sensor AF 200
- 2x Flow sensor VF 202B Connection cable length 2m
- 1x Immersion sensor TF A20-20-03 (KVT20/2/6), length 2m
- 1x Immersion sensor TF A20-50-03 (KVT 20/5/6), length 5m

Article number 9900902000

## 11.6 heatcon! Device bus cable

Our device bus cables are used when several devices need to be connected or longer distances need to be bridged.

- heatcon! Device bus cable 280 mm (plug / plug)
- heatcon! Device bus cable 3000 mm (plug / stranded wire)

Article number 9600906000

Article number 9600907000

Pin assignment of device bus cable

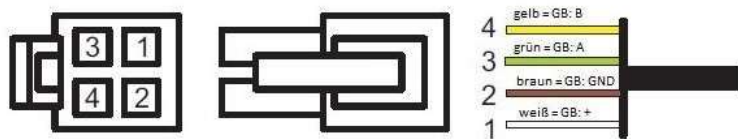

heatcon! EC  
heatcon! EM 100

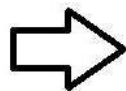

heatcon! EM 101

## 12 Technical data

### 12.1 heatcon! EC

**heatcon!**

**EC 13xx Pro  
MMI 200**



*heatcon!* Heating controller system comprising:

Control: ***heatcon! EC 13xx Pro***

Operation: ***heatcon! MMI 200***

Weather-compensated electronic boiler water temperature controller for all heat and cold producing energy sources

- Control of DHW heating
- Solar and solid fuel
- Buffer storage management
- Multi-valence and cascade management
- Up to 2 energy generator with one heatcon! EC
- Up to 3 control units in the system
- Up to 3 heating circuits with every heatcon! EC
- Up to 2 expansions (EM) for each heatcon! EC
- 1 Roomcontrol RC130 unit for each available heating circuit on the 2-wire bus
- Optionally with single room control *heatapp!*
  - Bonus in the ErP calculation
  - Up to 24 rooms
- Set-up, operation and service via app, PC or MMI 200
- Menu controlled set-up in just a few steps
- Free inputs and outputs can be used for other functions
- Sensors can be assigned to several functions
- App-based mobile remote control and maintenance
- MMI with clear display
- Adjustable MMI display
- User-friendly operation using speed buttons

1	Article number
heatcon EC 1351 Pro RS485 EbV EEZ-Bus	9600310000
heatcon EC 1321 Pro OpenTherm Bus	9600311000
MMI 200 white	9601400000
MMI 200 black	9600400000



Technical data	
heatcon! EC	
Installation	EC 1351 Pro top hat rail installation in the energy generator
Operating system	Enbeedet, Linux
Network connections, USB	<ul style="list-style-type: none"> <li>RJ45 Ethernet</li> <li>USB 2.0</li> </ul>
Power supply	230 V ±10 %, 50 Hz
Power consumption	max. 9VA
Protection class	I with functional earth (*)
IP rating	IP00
Fusing	User-supplied
Energy generator bus	heatcon! EC 1351Pro RS485 EbV GEN-Bus heatcon! EC 1321Pro Open Therm Bus
Ambient conditions	
<ul style="list-style-type: none"> <li>Storage temperature</li> <li>Operating temperature</li> </ul>	-25 ... +60 °C -10 ... +50 °C
Connections screw terminals	<ul style="list-style-type: none"> <li>Mains voltage L, N, </li> <li>1 x potential-free relay ARSP, max. 230V / 6A (Pin A1)</li> <li>2 x potential-free relay ARSP, max. 230V / 2A (Pin A2/A3)</li> <li>10 x relay 230V ONOR, max. 2A, sum current: max. 10A</li> <li>2 x opto-coupler input IOC 230V</li> <li>9 x sensor pulse input EFI</li> <li>3 x sensor pulse 0...10V input EFI 10V</li> <li>3 x pulse input PI</li> <li>2 x output 0...10V PWM O10VP</li> <li>Energy generator bus RS485 EbV GEN bus</li> <li>Connection room device bus RC (2-wire bus)</li> <li>Connection control unit MMI 200</li> <li>EbV device bus</li> </ul>
Standards	DIN EN 60730
Dimensions	210 x 90 x 61 mm (length x width x height) with top-hat rail
Weight	335 g
Colour heatcon! EC 1351 Pro	Grey

**\*) Note**

The **heatcon! EC 13xx Pro** is supplied with a top hat rail housing. Protection class I, earth conductor connection for functional purposes. **Protection against contact and the IP 20 degree of protection must be ensured by installation.**

**heatcon! MMI 200**

Installation	MMI 200 in standard cut-out 144 x 96 mm
Ambient conditions <ul style="list-style-type: none"><li>• Storage temperature</li><li>• Operating temperature</li></ul>	-25 ... +60 °C -10 ... +50 °C
Dimensions	144 x 96 x 29 mm (length x width x height)
Weight	125 g
MMI display dimensions	Graphic display 70 x 35 mm
MMI colour	Black or White

## 12.2 heatcon! EM 100

### heatcon! Extension module EM 100

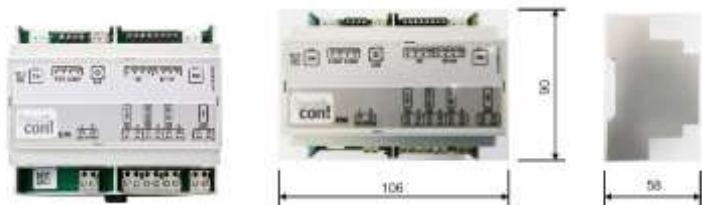

heatcon! Extension module EM 100 Article number 9600704000

#### heatcon! Extension module EM 100

##### Functions:

- Heating circuit expansion
- Expansion in-and outputs 0-10V / PVM

##### Features:

- Hat rail installation in the energy generator
- Up to 2 expansions (EM) for each heatcon! EC

#### Technical data

Installation	Hat rail installation in the energy generator
Outlets	EbV – device bus
Connection technology	4-wire technology, screw terminal connection
Maximum permissible cable length	50 m
Power supply	230 V ±10 %, 50 Hz
Power consumption	max. 9VA
IP class	0 (*)
IP rating	/ IP00
Fusing	User-supplied
Ambient conditions	
• Storage temperature	-25 ... +60 °C
• Operating temperature	-10 ... +50 °C
Connections screw terminals	<ul style="list-style-type: none"> <li>• Mains voltage L, N</li> <li>• 1 x potential-free relay ARSP, max. 230V / 2A</li> <li>• 3 x relay 230V ARS, max. 2A, sum current: max. 10A</li> <li>• 2 x sensor pulse input EFI</li> <li>• 2 x sensor pulse 0...10V input EFI 10V</li> <li>• 2 x output 0..10V-PWM A10VP</li> <li>• 2 x EbV – device bus</li> </ul>
Standards	DIN EN 60730
Dimensions	106 x 90 x 61 mm (length x width x height) with hat rail
Weight	240 g
Colour	Grey

**\*Note** The *heatcon! EM 100* is supplied with a top hat rail housing. Protection class I, earth conductor connection for functional purposes. Protection against contact and the IP 20 degree of protection must be ensured by installation.

## 12.3 heatcon! EM 101

### Extension module EM 101



heatcon! Extension module EM 101 Article number 9600708000

#### heatcon! Extension module EM 101

##### Functions:

- Heating circuit expansion
- Expansion in-and outputs 0-10V / PVM

##### Merkmale:

- Wall housing
- Up to 2 expansions (EM) for each heatcon! EC

#### Technical data

Installation	Wall-mounted case
Outlets	EbV – device bus
Connection technology	4-wire technology, screw terminal connection
Maximum permissible cable length	50 m
Power supply	230 V $\pm$ 10 %, 50 Hz
Power consumption	max. 9VA
IP class	IP 30
IP rating	/ IP00
Fusing	User-supplied
Ambient conditions <ul style="list-style-type: none"> <li>• Storage temperature</li> <li>• Operating temperature</li> </ul>	-25 ... +60 °C -10 ... +50 °C
Connections screw terminals	<ul style="list-style-type: none"> <li>• Mains voltage L, N</li> <li>• 1 x potential-free relay ARSP, max. 230V / 2A</li> <li>• 3 x relay 230V ARS, max. 2A, sum current: max. 10A</li> <li>• 2 x sensor pulse input EFI</li> <li>• 2 x sensor pulse 0...10V input EFI 10V</li> <li>• 2 x output 0..10V-PWM A10VP</li> <li>• 1 x EbV – device bus</li> </ul>
Standards	DIN EN 60730
Dimensions	145,5 x161 x 48 mm (length x width x height)
Weight	405 g
Colour	white

## 12.4 heatcon! EM 110 – OT

heat  
con!

### Extension module EM 110 – OT



### heatcon! Extension module EM 110 - OT

**Function:**

- OpenTherm module

**Attributes:**

- Hat rail housing
- Up to 4 heatcon! EM 110 – OT per heatcon! EC 1351 pro possible
- Each heatcon! EM 110 – OT up to 2 OpenTherm machines

### heatcon! Extension module EM 110 – OT

Article number 9600709000

**Technical data**

Installation	Hat rail housing in the energy generator
Outlets	GEN (GEN) – Bus 485 OpenTherm Bus
Connection technology	Screw terminal connection
Maximum cable length to enegery generator	50 m
Maximum cable length to OpenTherm	50 m
Power supply	via heatcon! EC 1351 pro
IP class	0
IP rating	IP00
Ambient conditions	
<ul style="list-style-type: none"> <li>• Storage temperature</li> <li>• Operating temperature</li> </ul>	-25 ... +60 °C -10 ... +50 °C
Connections screw terminals	<ul style="list-style-type: none"> <li>• 2 x energy generator bus 485</li> <li>• 2 x OpenTherm Bus</li> </ul>
Standards	DIN EN 60730
Dimensions	53 x 90 x 61 mm (length x width x height) including hat rail
Colour	Grey

## 12.5 heatcon! EM – GBA

heatcon!

### Extension module EM - GBA



### heatcon! Extension module EM - GBA

**Function:**

- Connection module when using more than 2 heatcon! EC

**Attribute:**

- Hat rail housing

### heatcon! Extension module EM – GBA

Article number 9600710000

### Technical data

Installation	Hat rail housing in the energy generator
Outlets	Device bus
Connection technology	<ul style="list-style-type: none"> <li>• Screw terminal connection</li> <li>• Plug contact</li> </ul>
Maximum cable length	100 m
cable cross-section	0,8 mm <sup>2</sup>
IP class	0
IP rating	IP00
Ambient conditions	
<ul style="list-style-type: none"> <li>• Storage temperature</li> <li>• Operating temperature</li> </ul>	-25 ... +60 °C -10 ... +50 °C
Connections	<ul style="list-style-type: none"> <li>• 2 x device bus screw terminal</li> <li>• 2 x devicebus plug contact</li> </ul>
Standards	DIN EN 60730
Dimensions	35 x 90 x 61 mm (length x width x height) including hat rail
Colour	Grey

## 12.6 Cable lengths and cross-sections

Cables for mains voltage (power supply, burner, Pumps, actuators)	
Cross-section	1.5 mm <sup>2</sup>
Maximum cable length	Unlimited cable length as part of an in-house installation

Cables for safety extra low voltage (sensors, analogue signal cables, contacts, etc.)	
Cross-section	0.5 mm <sup>2</sup>
Maximum cable length	100 m (double line) Longer distances are possible but increase the risk of interference.

Data bus connections	
Cross-section	0.6 mm
Type	J-Y(St)Y 1 x 2 x 0.6 mm
Maximum cable length	50 m (double line), longest section between the <i>heatcon! EC</i> and a device to be supplied). Longer distances are possible but increase the risk of interference.

## 12.7 Resistance values for sensors of type KTY20

°C	kΩ	°C	kΩ	°C	kΩ	°C	kΩ
-20	1,386	0	1,630	20	1,922	70	2,786
-18	1,393	2	1,658	25	2,000	75	2,883
-16	1,418	4	1,686	30	2,080	80	2,982
-14	1,444	6	1,714	35	2,161	85	3,082
-12	1469	8	1,743	40	2,245	90	3,185
-10	1,495	10	1,772	45	2,330	95	3,290
-8	1,522	12	1,802	50	2,418	100	3,396
-6	1,549	14	1,831	55	2,507		
-4	1,576	16	1,862	60	2,598		
-2	1,603	18	1,892	65	2,691		

## 12.8 Resistance values for sensors of type PT1000

°C	kΩ	°C	kΩ	°C	kΩ	°C	kΩ
0	1000	80	1308,93	140	1535,75	280	2048,76
10	1039,02	85	1327,99	150	1573,15	300	2120,19
20	1077,93	90	1347,02	160	1610,43	320	2191,15
25	1093,46	95	1366,03	170	1647,60	340	2261,66
30	1116,72	100	1385,00	180	1684,65	360	2331,69
40	1155,39	105	1403,95	190	1721,58	380	2401,27
50	1193,95	110	1422,86	200	1758,40	400	2470,38
60	1232,72	115	1441,75	220	1831,68	450	2641,12
70	1270,72	120	1460,61	240	1904,51	500	2811,00
75	1289,84	130	1498,24	260	1976,86		



## 13 Appendix

### 13.1 Hydraulic examples

#### NOTE

The following hydraulic examples are presented in simplified format matched to the *heatcon!* System. Hydraulic safety equipment is not shown.

#### 13.1.1 Single or two-stage GEN with unmixed heating circuit and DHW

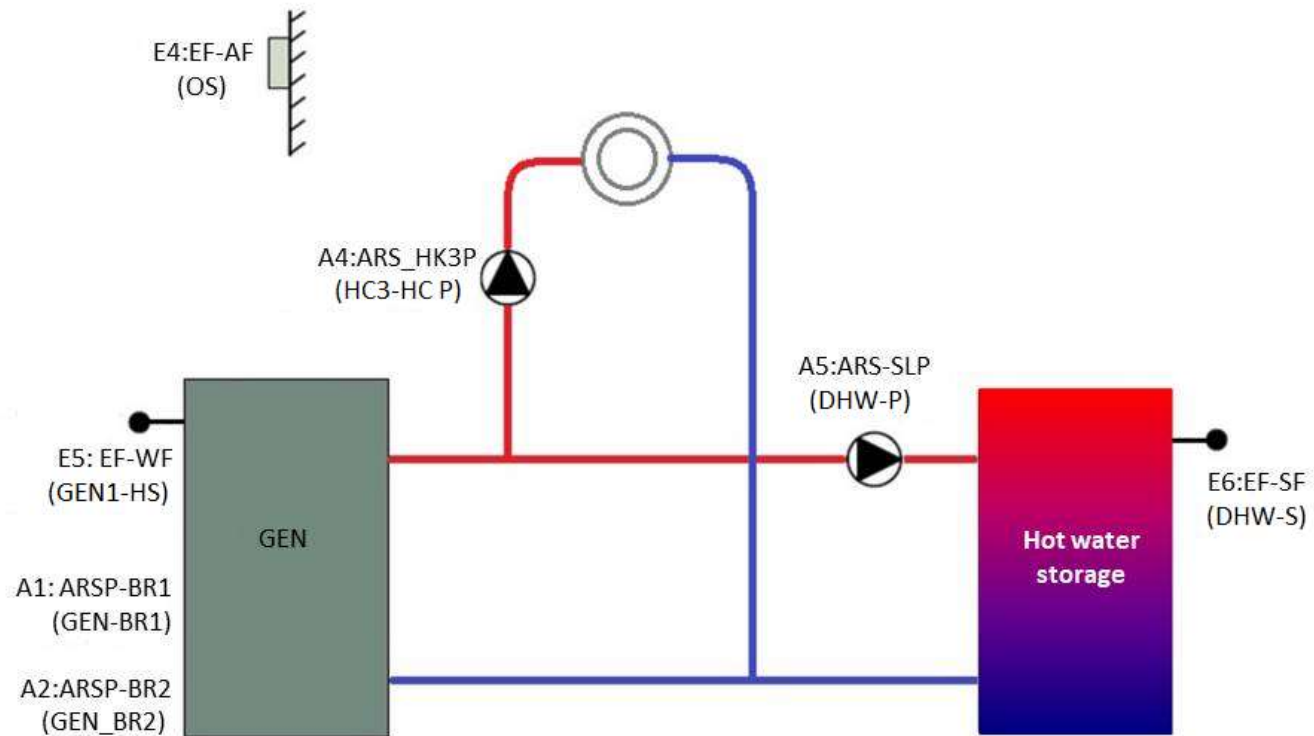

Fig. 72

Wizard hydraulic setup	Individual setting
Energy generator 1	Single-stage burner/two-stage burner
Energy generator 2	Off
Heating buffer	Off
Hot water operation	Storage pump
Heating circuit 1	Off
Heating circuit 2	Off
Heating circuit 3	Direct circuit
Differential control 1	Off

Inputs	Assignment	WG 1000 Connection (left)	Outputs	Assignment	WG 1000 Connection (right)
E1:EI	---	---	A1:ARSP-BR1	EEZ-BR1	18 / 19 (T1/T2)
E2:EI	---	---	A2:ARSP-BR2AUF	EEZ-BR2	2 / 4 (T6/T8)
E3:EI	---	---	A3:ARSP-BR2ZU	---	
E4:EF-AF	AF	39 / 40	A4:ARS-HKP3	HK3-HKP	28 / 29 / 30
E5:EF-WF	EEZ-WF (KF)	37 / 38	A5:ARS-SLP	WW-SLP	13 / 14 / 15
E6:EF-SF	WW-SF	18 / 19	A6:ARS-HK1AUF	---	
E7:EF-VF1	---	---	A7:ARS-HK1ZU	---	
E8:EF-VF2	---	---	A8:ARS-HK1P	---	
E9:EF-DIF1VF	---	---	A9:ARS-SOP	---	
E10:EF-DIF1PF	---	---	A10:ARS-HPP	---	
E11:EF-PF1	---	---	A11:ARS-HK2AUF	---	
E12:EF-PF2	---	---	A12:ARS-HK2ZU	---	
E13:EF-10V	---	---	A13:ARS-HK2P	---	
E14:EF-10V	---	---	A14:A10VP	---	
E15:EF-10V	---	---	A15:A10VP	---	

Inputs	Assignment	WG 1000 Connection (left)	Outputs	Assignment	WG 1000 Connection (right)
E16:EO-1	---	---			
E17:EO-2	---	---			

The **bold and underlined assignments** must be manually configured, all other assignments are automatically pre-assigned.

#### NOTE

In the setup wizards HC1 or HC2 can also be selected as unmixed heating circuits (unmixed circuits).

Here HC3 was selected as an example.

Menu	Parameter	Individual setting
No additional configuration is required	–	–

### 13.1.2 Single or two-stage H-GEN with one unmixed heating circuit and DHW separate circuit with a main Pump (HP) as a feed Pump

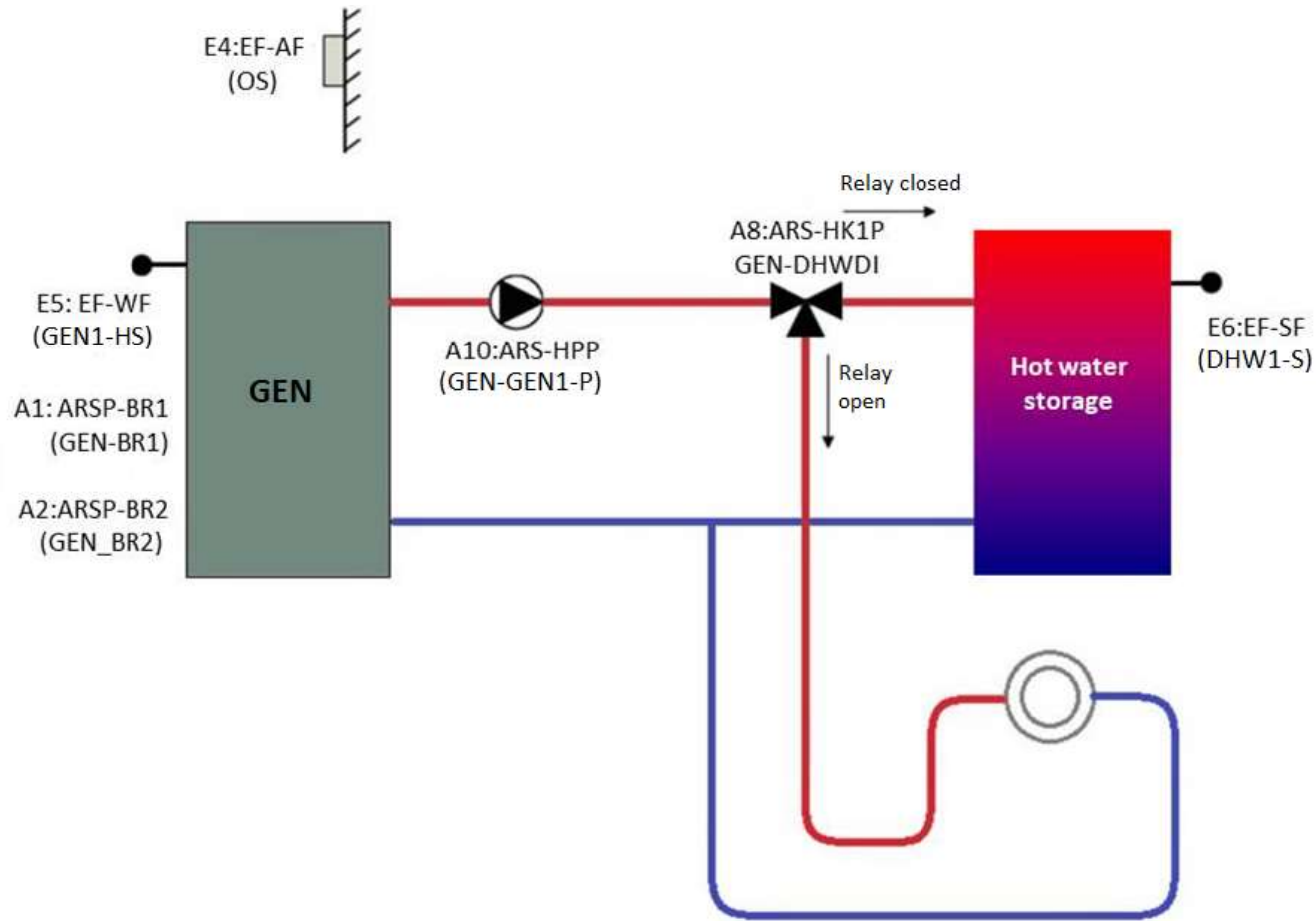

Fig. 73

Wizard hydraulic setup	Individual setting
Energy generator 1	Single-stage burner/two-stage burner
Energy generator 2	Off
Heating buffer	Off
Hot water operation	Storage pump

Wizard hydraulic setup	Individual setting
Heating circuit 1	Off
Heating circuit 2	Off
Heating circuit 3	Off
Differential control 1	Off

Inputs	Assignment	WG 1000 Connection (left)	Outputs	Assignment	WG 1000 Connection (right)
E1:EI	---	---	A1:ARSP-BR1	EEZ-BR1	18 / 19 (T1/T2)
E2:EI	---	---	A2:ARSP-BR2AUF	EEZ-BR2	2 / 4 (T6/T8)
E3:EI	---	---	A3:ARSP-BR2ZU	---	
E4:EF-AF	AF	39 / 40	A4:ARS-HKP3	HK3-HKP	28 / 29 / 30
E5:EF-WF	EEZ-WF (KF)	37 / 38	A5:ARS-SLP	WW-SLP	Wird nicht verwendet
E6:EF-SF	WW-SF	18 / 19	A6:ARS-HK1AUF	---	
E7:EF-VF1	---	---	A7:ARS-HK1ZU	---	
E8:EF-VF2	---	---	A8:ARS-HK1P	EEZ-UWW	25 / 26 / 27
E9:EF-DIF1VF	---	---	A9:ARS-SOP	---	
E10:EF-DIF1PF	---	---	A10:ARS-HPP	EEZ-EEZP	5 / 6 / 7
E11:EF-PF1	---	---	A11:ARS-HK2AUF	---	
E12:EF-PF2	---	---	A12:ARS-HK2ZU	---	
E13:EF-10V	---	---	A13:ARS-HK2P	---	
E14:EF-10V	---	---	Eingang 230V E16:EO-1	EEZ-BZ1	17 (B4)
E15:EF-10V	---	---	Eingang 230V E17:EO-2	EEZ-BZ2	1 (B5)
Ausgang A14:A10VP	---				

Inputs	Assignment	WG 1000 Connection (left)	Outputs	Assignment	WG 1000 Connection (right)
Ausgang A15:A10VP	---				

The **bold and underlined assignments** must be manually configured, all other assignments are automatically pre-assigned.

#### NOTE

The output *A5:ARS-SLP* is automatically pre-assigned by the hot water function. In this configuration, the output is not used, but is not however available for other functions.

Menu	Parameter	Individual setting
Expert / Configuration / function / Energy generator	Pump relais	A10:ARS
Expert / Configuration / function / Energy generator	Diverter valve hot water (UWW)	A8:ARS

13.1.3 Single or two-stage GEN with unmixed heating circuit, DHW and circulation pump

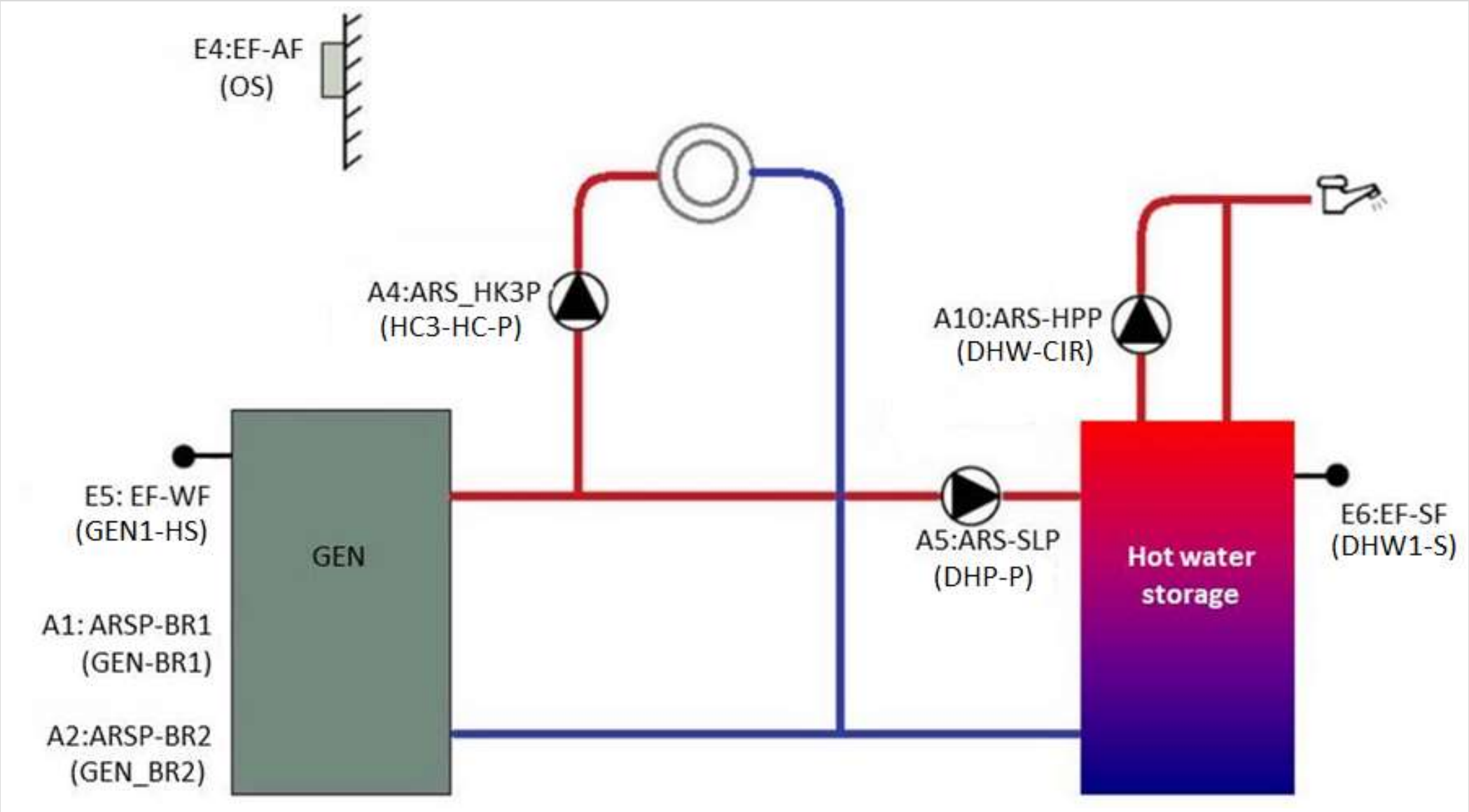

Fig. 74

Wizard hydraulic setup	Individual setting
Energy generator 1	Single-stage burner/two-stage burner
Energy generator 2	Off
Heating buffer	Off
Hot water operation	Storage pump
Heating circuit 1	Off
Heating circuit 2	Off
Heating circuit 3	Direct circuit
Differential control 1	Off

Inputs	Assignment	WG 1000 Connection (left)	Outputs	Assignment	WG 1000 Connection (right)
E1:EI	---	---	A1:ARSP-BR1	EEZ-BR1	18 / 19 (T1/T2)
E2:EI	---	---	A2:ARSP-BR2AUF	EEZ-BR2	2 / 4 (T6/T8)
E3:EI	---	---	A3:ARSP-BR2ZU	---	
E4:EF-AF	AF	39 / 40	A4:ARS-HKP3	HK3-HKP	28 / 29 / 30
E5:EF-WF	EEZ-WF (KF)	37 / 38	A5:ARS-SLP	WW-SLP	13 / 14 / 15
E6:EF-SF	WW-SF	18 / 19	A6:ARS-HK1AUF	---	
E7:EF-VF1	---	---	A7:ARS-HK1ZU	---	
E8:EF-VF2	---	---	A8:ARS-HK1P	---	
E9:EF-DIF1VF	---	---	A9:ARS-SOP	---	
E10:EF-DIF1PF	---	---	A10:ARS-HPP	WW-ZKP	5 / 6 / 7
E11:EF-PF1	---	---	A11:ARS-HK2AUF	---	
E12:EF-PF2	---	---	A12:ARS-HK2ZU	---	
E13:EF-10V	---	---	A13:ARS-HK2P	---	



Inputs	Assignment	WG 1000 Connection (left)	Outputs	Assignment	WG 1000 Connection (right)
E14:EF-10V	---	---	Eingang 230V E16:EO-1	EEZ-BZ1	17 (B4)
E15:EF-10V	---	---	Eingang 230V E17:EO-2	EEZ-BZ2	1 (B5)
Ausgang A14:A10VP	---				
Ausgang A15:A10VP	---				

The **bold and underlined assignments** must be manually configured, all other assignments are automatically pre-assigned.

#### NOTE

In the setup wizards HC1 or HC2 can also be selected as unmixed heating circuits (unmixed circuits).

Here HC3 was selected as an example.

Menu	Parameter	Individual setting
Expert / Configuration / function / Domestic hot water	circulation pump	A10:ARS

### 13.1.4 Single or two-stage H-GEN with one unmixed, one mixed heating circuit and DHW

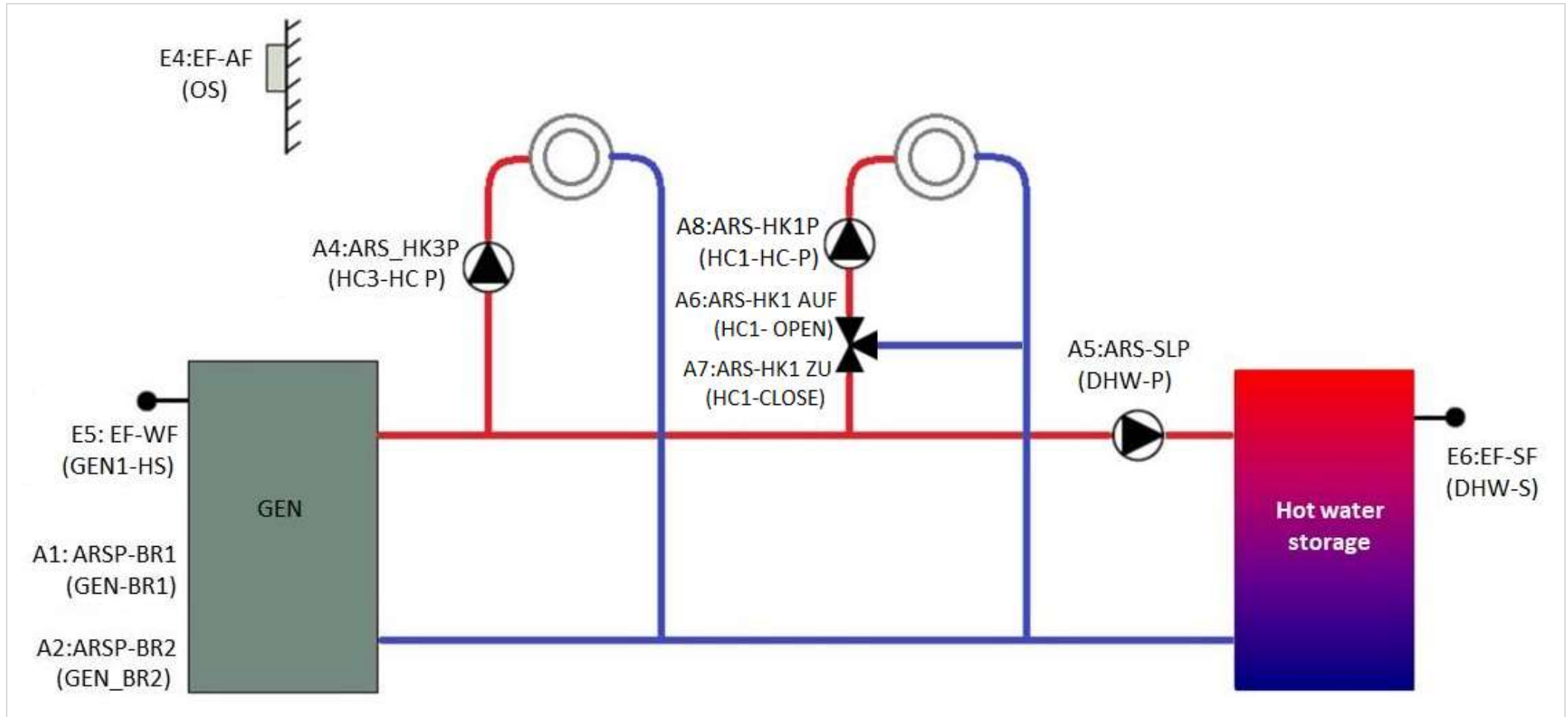

Fig. 75

Wizard hydraulic setup	Individual setting
Energy generator 1	Single-stage burner/two-stage burner
Energy generator 2	Off
Heating buffer	Off
Hot water operation	Storage pump

Wizard hydraulic setup	Individual setting
Heating circuit 1	Mixing circuit
Heating circuit 2	Off
Heating circuit 3	Direct circuit
Differential control 1	Off

Inputs	Assignment	WG 1000 Connection (left)	Outputs	Assignment	WG 1000 Connection (right)
E1:EI	---	---	A1:ARSP-BR1	EEZ-BR1	18 / 19 (T1/T2)
E2:EI	---	---	A2:ARSP-BR2AUF	EEZ-BR2	2 / 4 (T6/T8)
E3:EI	---	---	A3:ARSP-BR2ZU	---	
E4:EF-AF	AF	39 / 40	A4:ARS-HKP3	HK3-HKP	28 / 29 / 30
E5:EF-WF	EEZ-WF (KF)	37 / 38	A5:ARS-SLP	WW-SLP	13 / 14 / 15
E6:EF-SF	WW-SF	18 / 19	A6:ARS-HK1AUF	HK1 AUF	24
E7:EF-VF1	HK1-VF	35 / 36	A7:ARS-HK1ZU	HK1 ZU	23
E8:EF-VF2	---	---	A8:ARS-HK1P	HK1 P	25 / 26 / 27
E9:EF-DIF1VF	---	---	A9:ARS-SOP	---	
E10:EF-DIF1PF	---	---	A10:ARS-HPP	---	
E11:EF-PF1	---	---	A11:ARS-HK2AUF	---	
E12:EF-PF2	---	---	A12:ARS-HK2ZU	---	
E13:EF-10V	---	---	A13:ARS-HK2P	---	
E14:EF-10V	---	---	Eingang 230V E16:EO-1	EEZ-BZ1	17 (B4)
E15:EF-10V	---	---	Eingang 230V E17:EO-2	EEZ-BZ2	1 (B5)
Ausgang A14:A10VP	---				
Ausgang	---				

A15:A10VP					
-----------	--	--	--	--	--

The **bold and underlined assignments** must be manually configured, all other assignments are automatically pre-assigned.

**NOTE**

In the setup wizards HC2 can also be selected as an unmixed heating circuit (unmixed circuit).  
Here HC3 was selected as an example.

Menu	Parameter	Individual setting
No additional configuration is required	-	-

### 13.1.5 Single or two-stage H-GEN with one unmixed, two mixed heating circuits and DHW

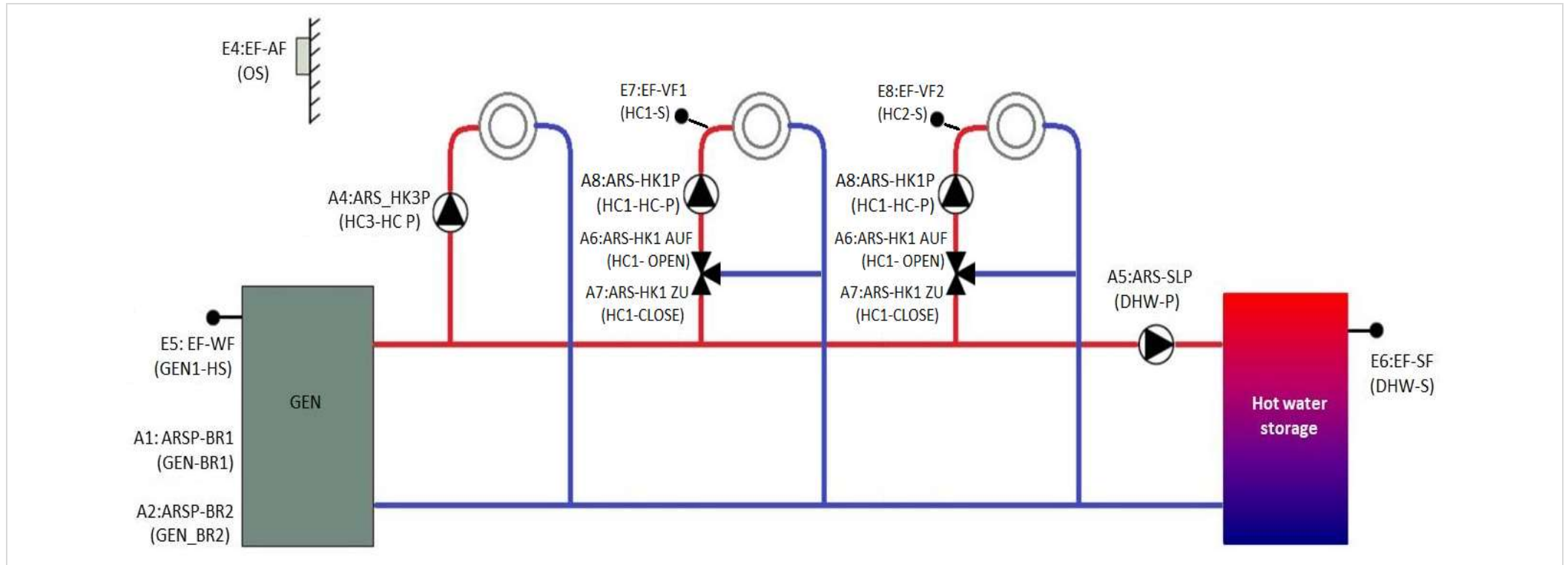

Fig. 76

Wizard hydraulic setup	Individual setting
Energy generator 1	Single-stage burner/two-stage burner
Energy generator 2	Off
Heating buffer	Off
Hot water operation	Storage pump
Heating circuit 1	Mixed circuit 1
Heating circuit 2	Mixed circuit 2
Heating circuit 3	Direct circuit
Differential control 1	Off

Inputs	Assignment	WG 1000 Connection (left)	Outputs	Assignment	WG 1000 Connection (right)
E1:EI	---	---	A1:ARSP-BR1	EEZ-BR1	18 / 19 (T1/T2)
E2:EI	---	---	A2:ARSP-BR2AUF	EEZ-BR2	2 / 4 (T6/T8)
E3:EI	---	---	A3:ARSP-BR2ZU	---	
E4:EF-AF	AF	39 / 40	A4:ARS-HKP3	HK3-HKP	28 / 29 / 30
E5:EF-WF	EEZ-WF (KF)	37 / 38	A5:ARS-SLP	WW-SLP	13 / 14 / 15
E6:EF-SF	WW-SF	18 / 19	A6:ARS-HK1AUF	HK1 AUF	24
E7:EF-VF1	HK1-VF	35 / 36	A7:ARS-HK1ZU	HK1 ZU	23
E8:EF-VF2	HK2-VF	16 / 17	A8:ARS-HK1P	HK1 P	25 / 26 / 27
E9:EF-DIF1VF	---	---	A9:ARS-SOP	---	
E10:EF-DIF1PF	---	---	A10:ARS-HPP	---	
E11:EF-PF1	---	---	A11:ARS-HK2AUF	HK2 AUF	9
E12:EF-PF2	---	---	A12:ARS-HK2ZU	HK2 ZU	8
E13:EF-10V	---	---	A13:ARS-HK2P	HK2 P	10 / 11 / 12
E14:EF-10V	---	---	Eingang E16:EO-1	EEZ-BZ1	17 (B4)
E15:EF-10V	---	---	Eingang E17:EO-2	EEZ-BZ2	1 (B5)
Ausgang A14:A10VP	---				
Ausgang A15:A10VP	---				

The **bold and underlined assignments** must be manually configured, all other assignments are automatically pre-assigned.

Menu	Parameter	Individual setting
No additional configuration is required	–	–

### 13.1.6 Buffer loading control for heating circuit and DHW Requests

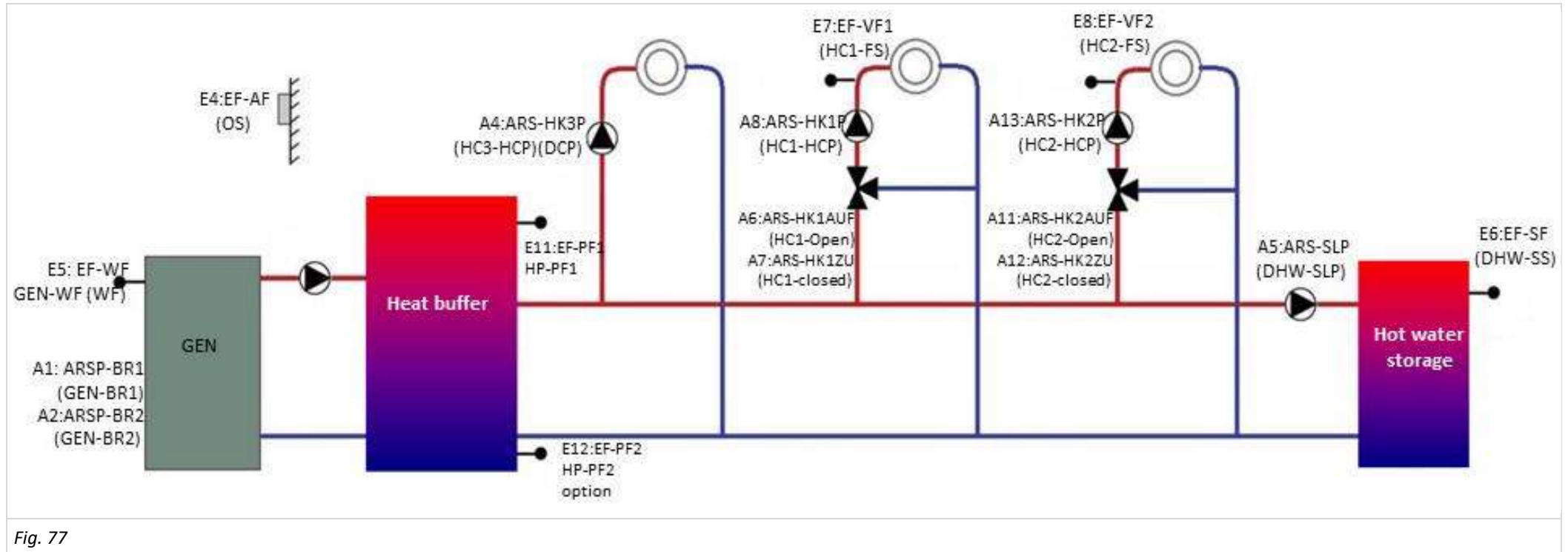

Fig. 77

Wizard hydraulic setup	Individual setting
Energy generator 1	Single-stage burner/two-stage burner
Energy generator 2	Off
Heating buffer	Charge control
Hot water operation	Storage pump
Heating circuit 1	Mixed circuit 1
Heating circuit 2	Mixed circuit 2
Heating circuit 3	Direct circuit
Differential control 1	Off

Inputs	Assignment	WG 1000 Connection (left)	Outputs	Assignment	WG 1000 Connection (right)
E1:EI	---	---	A1:ARSP-BR1	EEZ-BR1	18 / 19 (T1/T2)
E2:EI	---	---	A2:ARSP-BR2AUF	EEZ-BR2	2 / 4 (T6/T8)
E3:EI	---	---	A3:ARSP-BR2ZU	---	
E4:EF-AF	AF	39 / 40	A4:ARS-HKP3	HK3-HKP	28 / 29 / 30
E5:EF-WF	EEZ-WF (KF)	37 / 38	A5:ARS-SLP	WW-SLP	13 / 14 / 15
E6:EF-SF	WW-SF	18 / 19	A6:ARS-HK1AUF	HK1 AUF	24
E7:EF-VF1	HK1-VF	35 / 36	A7:ARS-HK1ZU	HK1 ZU	23
E8:EF-VF2	HK2-VF	16 / 17	A8:ARS-HK1P	HK1 P	25 / 26 / 27
E9:EF-DIF1VF	---	---	A9:ARS-SOP	---	
E10:EF-DIF1PF	---	---	A10:ARS-HPP	HP-HPP	5 / 6 / 7
E11:EF-PF1	HP-PF1	25 / 26	A11:ARS-HK2AUF	HK2 AUF	9
E12:EF-PF2	HP-PF2 (optional)	6 / 7	A12:ARS-HK2ZU	HK2 ZU	8
E13:EF-10V	---	---	A13:ARS-HK2P	HK2 P	10 / 11 / 12
E14:EF-10V	---	---	Eingang 230V E16:EO-1	EEZ-BZ1	17 (B4)
E15:EF-10V	---	---	Eingang 230V E17:EO-2	---	---
Ausgang A14:A10VP	---				
Ausgang A15:A10VP	---				

The **bold and underlined assignments** must be manually configured, all other assignments are automatically pre-assigned.

Menu	Parameter	Individual setting
No additional configuration is required	–	–



### 13.1.7 Buffer - discharge control to HC and DHW with solid and solar

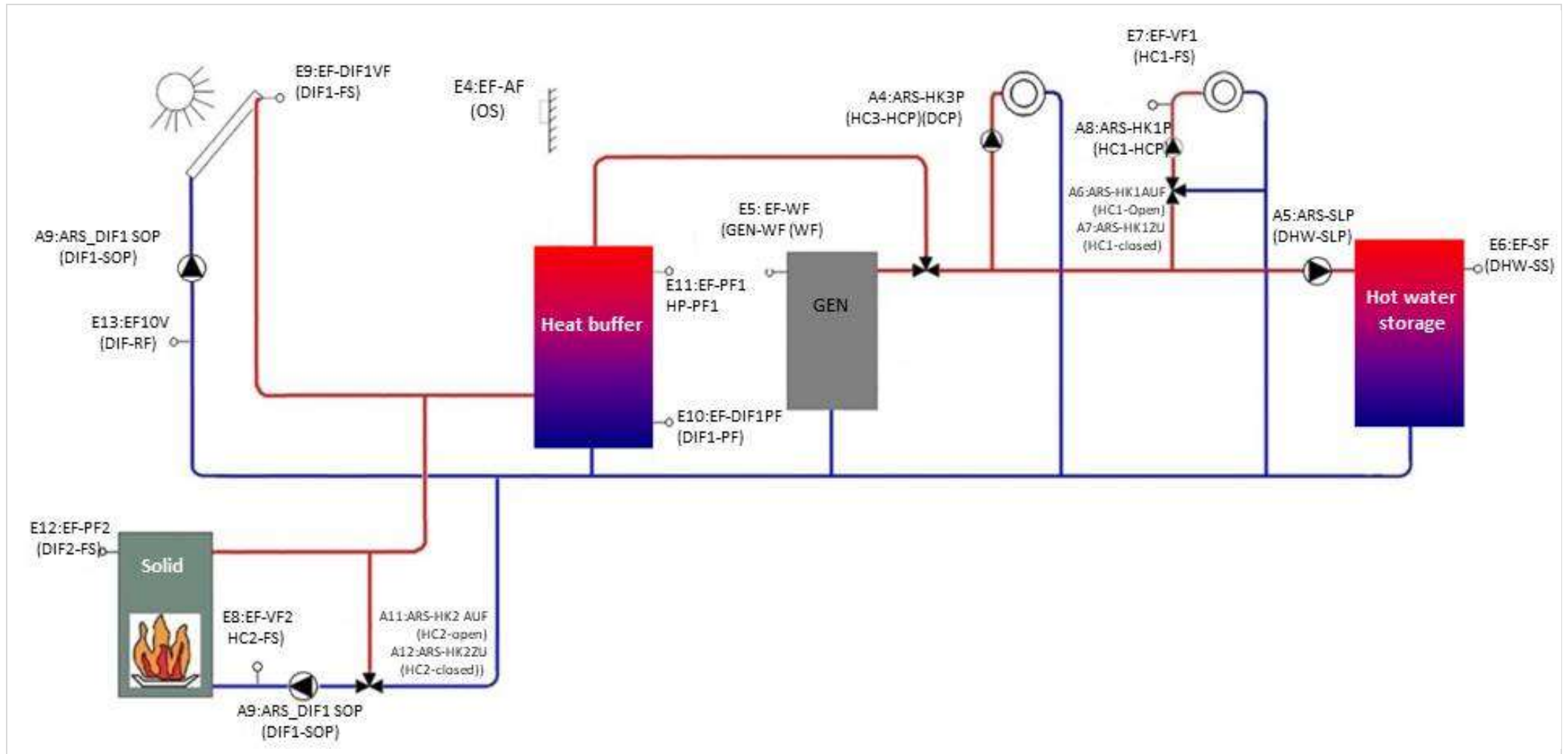

Fig. 78

Wizard hydraulic setup	Individual setting
Energy generator 1	single-stage burner
Energy generator 2	Off

Wizard hydraulic setup	Individual setting
Heating buffer	Discharge control-1
Hot water mode	Storage Pump
Heating circuit 1	Mixed circuit1
Heating circuit 2	Off
Heating circuit 3	Direct circuit
Differential1	Solar

The solids and return flow rise function must be activated in the configuration menu.

Configuration - Function - Difference 2

Menu	Parameter	Individual setting
Configuration – function – Difference 2	Function	Solid
	Leader sensor	E12:EF
	Storage sensor	E10:EF
	Pump relais	A2:ARSP
Configuration – function - Return flow	Return flow sensor	E8:EF
	Mixing valve	Heating circuit 2
Configuration – function – Difference 1	Return flow sensor	E13:EF10V
Solid fuel – Basic settings	Minimum temperature	60°C

Inputs	Assignment	WG 1000 Connection (left)	Outputs	Assignment	WG 1000 Connection (right)
E1:EI	---	---	A1:ARSP-BR1	EEZ-BR1	18 / 19 (T1/T2)
E2:EI	---	---	A2:ARSP-BR2AUF	EEZ-BR2	2 / 4 (T6/T8)
E3:EI	---	---	A3:ARSP-BR2ZU	---	
E4:EF-AF	AF	39 / 40	A4:ARS-HKP3	HK3-HKP	28 / 29 / 30
E5:EF-WF	EEZ-WF (KF)	37 / 38	A5:ARS-SLP	WW-SLP	13 / 14 / 15
E6:EF-SF	WW-SF	18 / 19	A6:ARS-HK1AUF	HK1 AUF	24

Inputs	Assignment	WG 1000 Connection (left)	Outputs	Assignment	WG 1000 Connection (right)
E7:EF-VF1	HK1-VF	35 / 36	A7:ARS-HK1ZU	HK1 ZU	23
E8:EF-VF2	HK2-VF	16 / 17	A8:ARS-HK1P	HK1 P	25 / 26 / 27
E9:EF-DIF1VF	DIF1-VF	31 / 32	A9:ARS-SOP	DIF1-SOP	20 / 21 / 22
E10:EF-DIF1PF	DIF1-PF	10 / 11	A10:ARS-HPP	HP-HPP	5 / 6 / 7
E11:EF-PF1	DIF2-VF	25 / 26	A11:ARS-HK2AUF	HK2 AUF	9
E12:EF-PF2	DIF1 VF	6 / 7	A12:ARS-HK2ZU	HK2 ZU	8
E13:EF-10V	DIF1-RF	14 / 15	A13:ARS-HK2P	HK2 P	HK2-HKP wird hier nicht verwendet
E14:EF-10V	---	---	Eingang 230V E16:EO-1	EEZ-BZ1	17 (B4)
E15:EF-10V	---	---	Eingang 230V E17:EO-2	---	---
Ausgang A14:A10VP	---				
Ausgang A15:A10VP	DIF1-DIFP	23 / 24			

The **bold and underlined assignments** must be manually configured, all other assignments are automatically pre-assigned.

### 13.2 heatcon! EC connections for print and notes

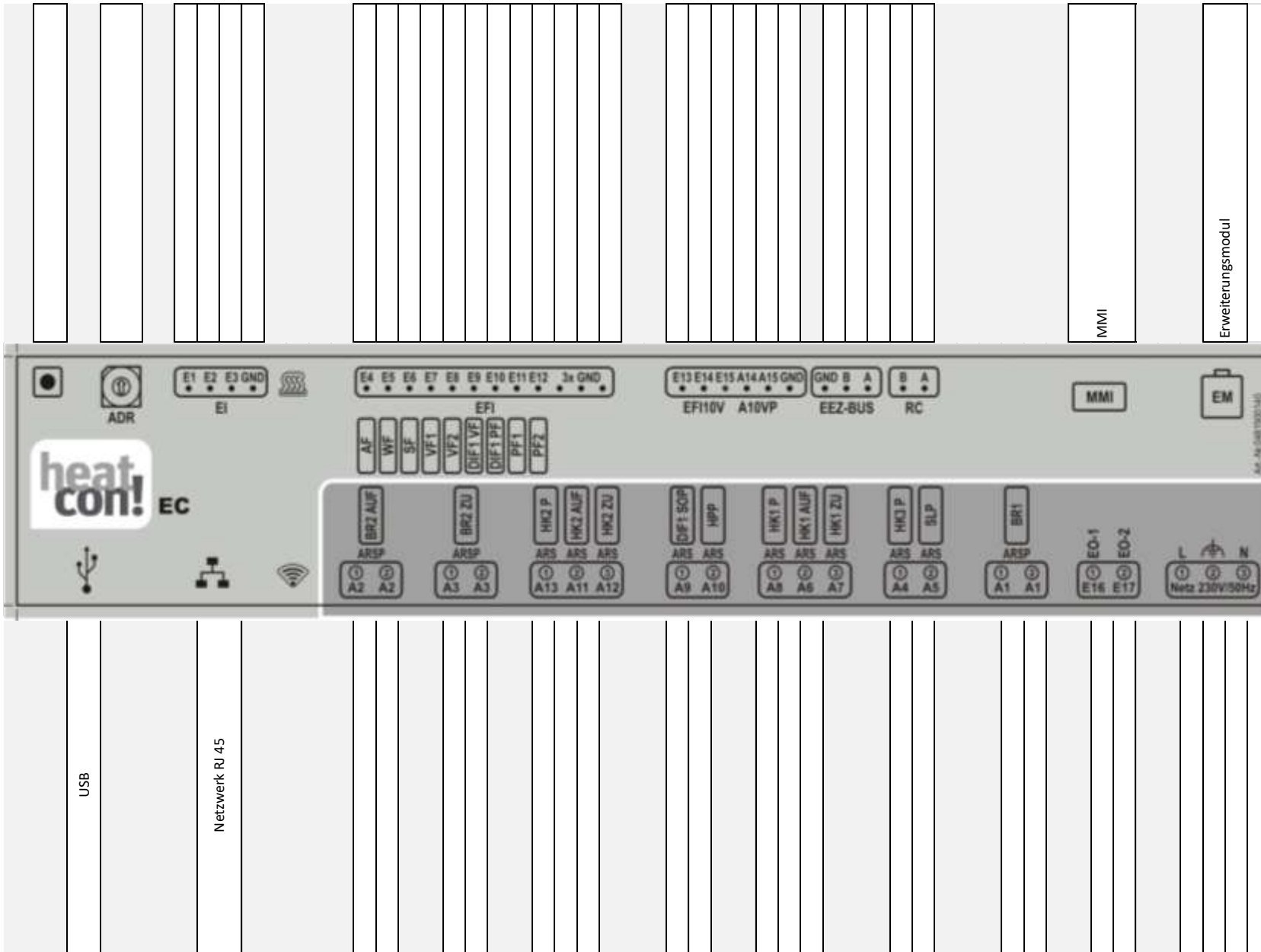

- EI Eingang Impuls
  - EFI Eingang Fühler Impuls
  - EF110V Eingang Fühler Impuls 10'
  - EO Eingang Optokoppler (Wärmemengenzähler)
  - ARS Ausgang Relais Schließer
  - ARSP Ausgang Relais Schließer potentialfrei
  - A10VP Ausgang 10V PWM (Pulsweitenmodulation)
  - EEZ Energieerzeugerbus
  - Bus
  - RC Room control
  - MMI Machine machine interface
  - EM Extension module
- Kontaktbelastbarkeit Relais:
- A1 230 V / 6A
  - A2-A13 230 V / 2A

### 13.3 Switching times table

Room	DAY	Switching time 1	Switching time 2	Switching time 3
	Mo			
	Tu			
	We			
	Th			
	Fr			
	Sa			
	Su			
	Mo			
	Tu			
	We			
	Th			
	Fr			
	Sa			
	Su			
	Mo			
	Tu			
	We			
	Th			
	Fr			
	Sa			
	Su			
	Mo			
	Tu			
	We			
	Th			

Room	DAY	Switching time 1	Switching time 2	Switching time 3
	Fr			
	Sa			
	Su			
	Mo			
	Tu			
	We			
	Th			
	Fr			
	Sa			
	Su			
	Mo			
	Tu			
	We			
	Th			
	Fr			
	Sa			
	Su			

## 13.4 Login data

**NOTE** the login data to your *heatcon!* system here:

User level	User name	Password
Expert:	<input type="text"/>	<input type="text"/>
Owner:	<input type="text"/>	<input type="text"/>

When connecting to the single room control *heatapp!* please record the password of the *heatapp! gateway* here:

heatapp! gateway	
Password:	<input type="text"/>

---

### NOTE

Create a setup log file and a data backup after completing the installation.

---

## 13.5 Access data lost - Forgotten password

During the setup of the heatapp! system, access data is created. For this purpose, a user with the expert role and a user with the administrator role must be created. The access data consists of a user name and password.

A separate, independent password is assigned for the heatapp! gateway during setup.

As of software version 2.2.39533, the heatapp! system has a "forgotten password" function. This function can be used to replace the access data. Read further in chapter **Fehler! Verweisquelle konnte nicht gefunden werden.**

For systems with an older software version, continue reading in chapter 13.5.2

### 13.5.1 Forgotten password function

The function is only available at home in the local network and must be executed via a web browser (e.g. Mozilla Firefox, Google Chrome or similar) on the PC. The wizard of the "Forgotten password" function can be called up via the web browser. The system automatically detects if a heatapp! gateway is being used. When the wizard is executed, new access data is created for a user with the expert role and a user with the owner role. If a heatapp! gateway is connected to the system, a new password is also created for the gateway.

The Forgot Password Wizard ends with the saving of a txt document, which is saved on a USB stick.

When this USB stick is plugged into the heatapp! base, the device first checks the file on the stick. If there are suitable access data for an expert and an owner here,

- all previous users with the respective rights are deleted.
- all devices connected to the system are logged out (both via the web browser function and in the app).
- the new access data for a specialist and an administrator and, if available, a new password for the gateway, are read in.

This function protects the users from unauthorised changes of the access data by third parties, as all authorised users become aware of the password change through the logout.



#### Note

If the forgotten password function is executed on a tablet or smartphone, it must be ensured that the file created can subsequently be saved on a USB stick.

The units can be called up by means of an Internet browser on a PC / laptop both via the IP address, which is read out from the router menu, and via the host name of the units.

Device	Hostname
heatcon! EC	heatapp-ec



## login

Please login to the base using the expert or owner access.

heatappl uses open source software. Click [here](#) to obtain more information.

login:

password:

[Forgot password](#)

login

The "Forgotten password" link is located below the login screen.

## Forgot password

If you have forgotten your access data, you can create new ones here. To do this, follow the wizard and at the end save the resulting "password.txt" file on a USB stick.

If the USB stick with the "password.txt" file is inserted into the unit, all existing access data and the user rights management are deleted and replaced by the user data created in the "password.txt" file.

next

The wizard guides you step by step through the function so that new access data can be generated for the system.

## Forgot password

Please enter username and password for a new owner access.

login

password

repeat your password

next

First, the user name and password for a new owner access must be created.

## Forgot password

Now please enter the new credentials for the expert-account.

Then the user name and password for a new expert access is created.

### attention



The login name does not meet the requirements. It has to be at least 5 characters long and can only contain the characters a-z, A-Z, 0-9, äöü, ÄÖÜ and B.

### attention



Please enter a password with a minimum length of 5 signs which belongs to 2 character classes, without spaces and umlauts (äöü).

The system automatically checks whether the new access data meet the necessary requirements. If this is not the case, a note appears.

## Forgot password

Please enter a new password for the gateway.

next

skip

If a gateway is connected to the heatapp! base, a new password for the gateway can be assigned here.

### Note:

If the gateway password is to be changed and the software version of the gateway is lower than 2.2.39533, an update can be installed via USB stick for gateways with a software version of 2.1.xxx or higher so that the forgotten password function becomes available. The installation of the USB update is described in chapter **Fehler! Verweisquelle konnte nicht gefunden werden.**

## Passwort vergessen

Die neuen Zugangsdaten sind erstellt. Mit „Speichern“ laden Sie die Passwort zurücksetzen Datei auf Ihren PC (in den eingestellten Download-Bereich) herunter. Kopieren Sie die Datei „password.txt“ auf einen leeren USB-Speicherstick.

Wird der USB Stick mit der „password.txt“ Datei an der heatapp! base eingesteckt, werden alle vorhandenen Zugangsdaten sowie die Rechteverwaltung der Benutzer gelöscht und durch die in der „password.txt“ Datei angelegten Benutzerdaten ersetzt.

Speichern

zurück zum Login

Download the file to your PC / laptop

Name	Änderungsdatum	Typ	Größe
password.txt	04.11.2021 08:36	Textdokument	1 KB

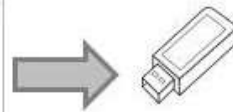

and save it on an empty USB stick.

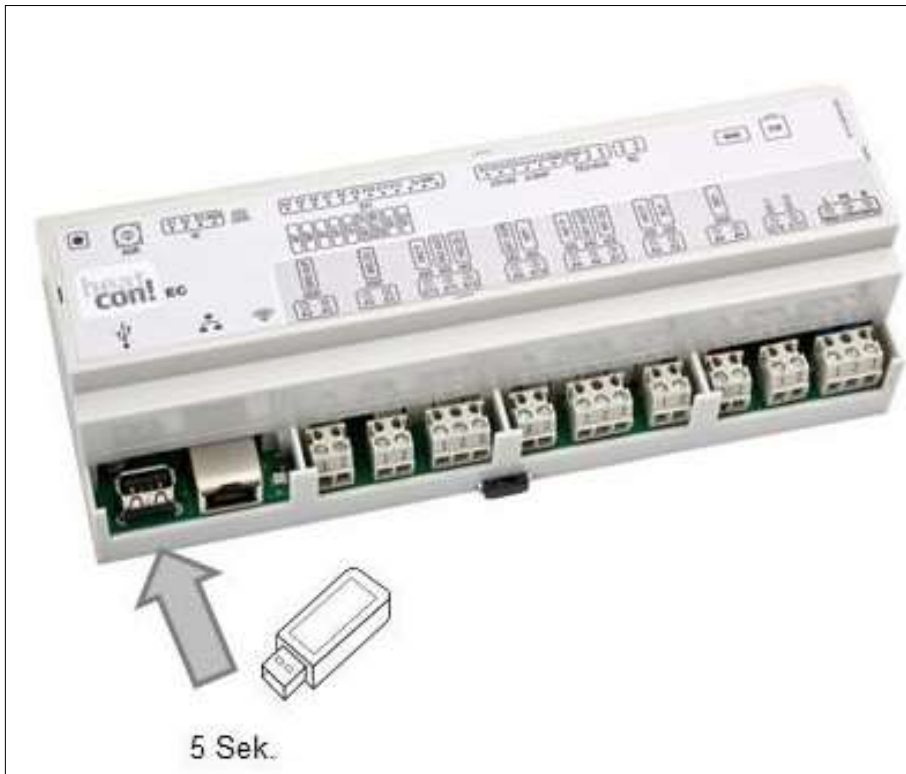

Plug the USB stick into the heatapp! base for approx. 5 seconds.

The unit checks the file if it is OK,

- all previous users with the respective rights are deleted.
- all devices connected to the system are logged out (both via the web browser function and in the app).
- The new access data for a specialist and an administrator and, if available, a new password for the gateway, are created.

You can then log in with the new access data.



If the USB stick is plugged into the PC / laptop after the password has been changed, the log file can be displayed in addition to the password file.

By opening the files, you can read out the contents.



```
password.txt - Editor
Datei Bearbeiten Format Ansicht Hilfe
admin Brita:Brita
expert Astrid:Astrid
gateway -:heatapp!
```



```
password.log - Editor
Datei Bearbeiten Format Ansicht Hilfe
2021-12-07 09:19:19 line 1: admin: 'brita' : 'Brita'
2021-12-07 09:19:19 line 3: expert: 'astrid' : 'Astrid'
2021-12-07 09:19:19 line 5: gateway: '-' : 'heatapp!'
```

By opening the files, you can read out the contents.

► **Note**

Never save a forgotten password file and a reset file on a USB stick. The reset file inevitably deletes all data on the unit and resets it to factory settings.

### 13.5.2 Reset without access data

To perform a factory reset without access data, an empty USB memory stick is required.

1. Use a blank USB memory stick with VFAT formatting
2. Create a blank text document and name it "Reset"
  - Open the USB stick on your PC / Laptop
  - Right-click
  - New
  - Text document
  - Rename it to "Reset.txt"
3. Disconnect **heatapp! base** from the LAN connection to the home network.
4. Connect **heatapp! base** to the power supply.
5. Insert the USB stick with the Reset.txt file in the **heatapp! base**.
6. Wait until the red network LED light is on.

The reset function erases all data from the devices. The data cannot be retrieved any more. Further use requires an entirely new set-up.

► **Note**

Resetting the **heatapp! gateway** results in the mandatory resetting of all radio components.