

---

# Control system

---

# THETA

## For the heating specialist Operating and installation instructions

Standard unit

Remote unit RS

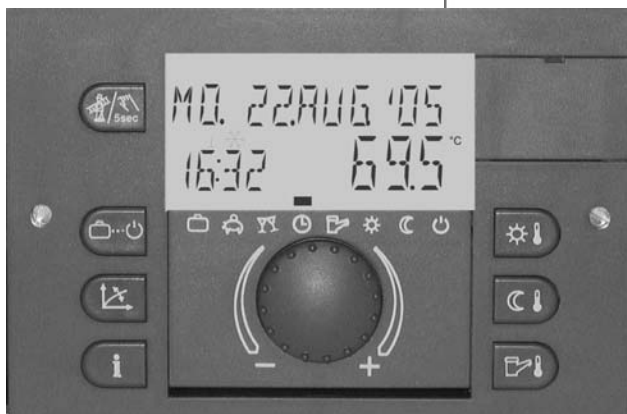
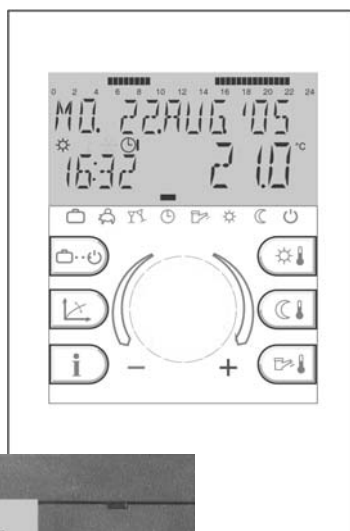

# Contents

<b>General safety instructions .....</b>	<b>3</b>
<b>Safety measures for EMC - conform installation .....</b>	<b>3</b>
<b>Standard unit .....</b>	<b>5</b>
Mounting .....	5
Electrical installation .....	5
Terminal assignment .....	6
<b>Wall socket MS-K .....</b>	<b>7</b>
Electrical installation .....	7
Terminal assignment .....	8
<b>Remote control unit RS .....</b>	<b>9</b>
Mounting location.....	9
Mounting .....	9
Terminal assignment .....	10
Electrical connections (control unit).....	10
Data bus addressing.....	10
<b>Equipment.....</b>	<b>12</b>
Outdoor sensor AF (OT).....	12
Immersion sensor KVT .....	12
Flow sensor VF .....	13
Resistance values of the sensor elements versus temperature.....	14
<b>Starting up the control unit.....</b>	<b>15</b>
Code-Input .....	15
<b>Automatic SET-Function .....</b>	<b>16</b>
<b>Alarm messages.....</b>	<b>18</b>
<b>Heating system information .....</b>	<b>19</b>
<b>Level synoptic .....</b>	<b>23</b>
Synoptic of the specialist parameters and control options .....	26

## General safety instructions

All electrical connections and safety measures have to be carried out by a specialist according to the valid norms and VDE-guidelines as well as the local instructions.

The electrical connection must be fixed (see instructions by VDE 0100).

The electrical connection has to be done according to the wiring diagram of the respective boiler control panel.

### Important!

**Deenergize the boiler before opening. Unprofessional plugging attempts under voltage may damage the control or cause dangerous electrical shocks.**

## Safety measures for EMC - conform installation

1. Cables with mains voltage must be generally installed separately from sensor and data bus cables. In this case a minimum distance of 2 cm must be observed. Crossing of lines is permitted.

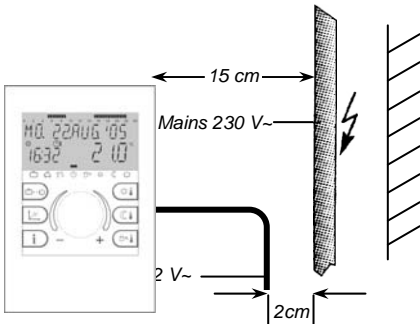

Fig. 1: Minimum distance for cable installations

2. Controls with own mains connection require a separate installation of mains and sensor or data bus cable. When using cable ducts such with internal separators are recommended.

3. Installing control or remote units close to other components with electro magnetic emission such as solid state relays, motors, transformers, dimmers, micro wave ovens, TV-sets, loud-speakers, computers, radio telephones etc. a minimum distance of 40 cm must be observed.

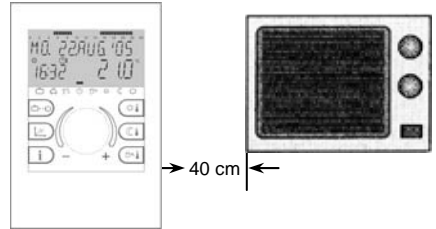

Fig. 2: Minimum distance to other electric supply

4. Between remote units and standard unit a minimum distance of 40 cm has to be observed. Several standard units may be installed side by side.
5. The mains connection of the heating plant (standard unit or boiler control panel) must be carried out as an independent electric circuit. It is not permitted to install fluorescent tubes or other machines that could produce interferences to the same electrical circuit.

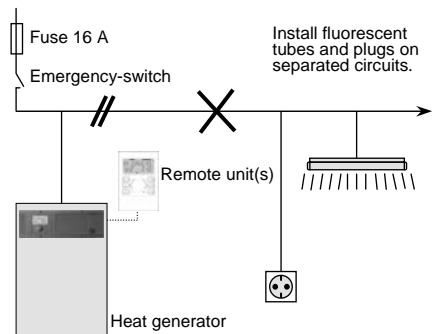

Fig. 3: Leading of electrical cables in the boiler room

6. All data bus cables must be carried out in shielded version.  
Recommended cable:  
J-Y(St)Y 1 x 2 x 0.6mm<sup>2</sup>
7. The shielding of the cable has to be connected with earth potential, i.e. boiler covering, connecting terminals - for earth potential etc. Multiple grounding is not permitted (humming loop).

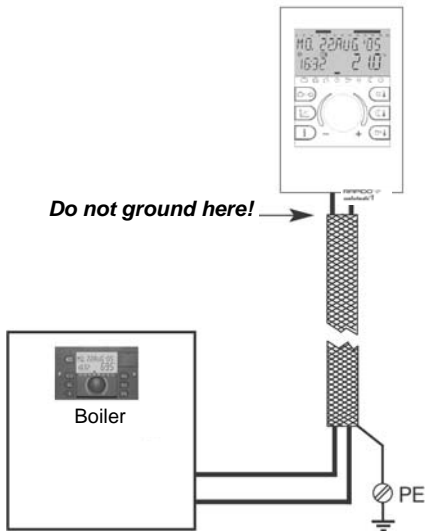

Fig. 4: Single grounding of shielding

In stellate data bus networks shall be no double grounding. The grounding must be made unilaterally in the star-point.

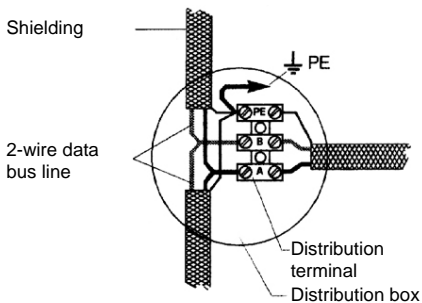

Fig. 5: Grounding in star shaped networks

8. The outside sensor may not be installed close to transmitter- or receiver-equipment (on garage walls close to receivers for radio-controlled garage door openers, ham operator antennas, radio controlled alert systems or close to big radio transmission plants).

### Cable dimensions and maximum cable length

For all 230V~ cables such as power supply, burner, pumps, actuators: 1.5 mm<sup>2</sup>

Maximum cable length:

Unlimited cable length within house installation

For all low voltage cables such as sensors, extern selectors, bus and analogue in- and outputs, heat requiring by means of extern contact, modem connection cables, etc.: 0.5 mm<sup>2</sup>

Maximum cable length: 100 m

Longer distances are possible but increase the risk of interferences.

Data bus connections: 0.6 mm<sup>2</sup>

Recommended cable:

J-Y(St)Y 1 x 2 x 0.6 mm<sup>2</sup>

Maximum cable length: 100 m

Longer distances are possible but increase the risk of interferences.

## Standard unit



### Mounting

All standard units are designed exclusively as units for incorporation and will be installed from the front side into the boiler panel after finishing the electrical wiring. The instrument is fastened by a quarter turn clockwise of the quick clamping devices at the left and right side of the front panel (1).

Removal is done in opposite direction.

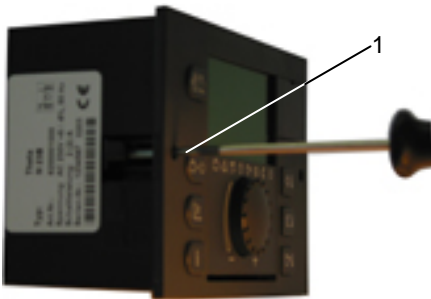

### Electrical installation

The electrical installation to the control equipment is done at the back side of the instrument via the four enclosed connecting terminals X1, X2, X3 and X4 corresponding to the identification on the coloured-marked connection pads.

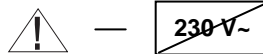

**All blue marked connecting terminals (X1) work with safety low voltage and must not get into contact with the mains voltage. At non-observance the instrument will definitely be destroyed and any warranty gets lost.**

Red marked connecting terminals (X2...X4) principally may work with mains voltage according to the current operation conditions.

For further information see documentation of the boiler manufacturer.

Electrical connection see next page.

### Note:

Cables with mains voltage must be installed **separate** from low voltage cables (data bus, sensors etc.). It is strictly prohibited to use one **cable** for both voltages. Sensor cables and data bus cables **may not** be installed **together** with mains voltage cables supplying electrical appliance which are not suppressed according to EN 60555-2.

## Terminal assignment

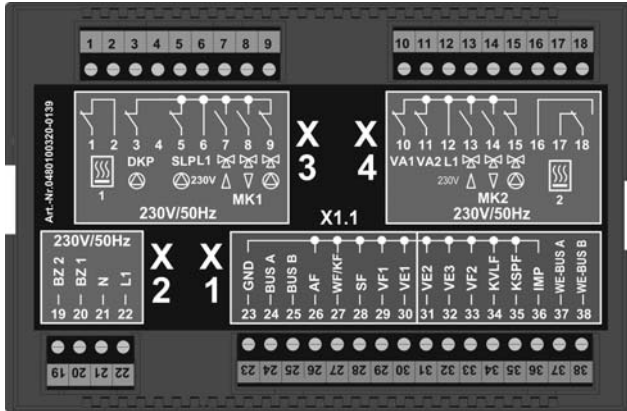

### 230 V~ Connections

- 1 – Floating exit for heat generator, output (stage 1)
- 2 – Floating exit for heat generator, input (stage 1)
- 3 – Pump for direct heating circuit
- 4 – not connected, used for coding
- 5 – Domestic hot water charging pump
- 6 – L 1 / 230 V~
- 7 – Mixing valve 1 OPEN
- 8 – Mixing valve 1 CLOSED
- 9 – Pump for mixed heating circuit 1
- 10 – Variable output 1
- 11 – Variable output 2
- 12 – L 1 / 230 V~
- 13 – Mixing valve 2 OPEN
- 14 – Mixing valve 2 CLOSED
- 15 – Pump for mixed heating circuit 2
- 16 –
- 17 – Floating exit for heat generator, output (stage 2)
- 18 – Floating exit for heat generator, input (stage 2)
- 19 – Operat. hours counter burner - (stage 2)
- 20 – Operat. hours counter burner - (stage 1)
- 21 – N / 230 V~
- 22 – L 1 / 230 V~ } mains

### Sensor and data bus connections

- 23 – Ground for data bus and sensors
- 24 – Data bus signal A
- 25 – Data bus signal B
- 26 – Outdoor sensor
- 27 – Sensor heat generator/boiler
- 28 – Domestic hot water sensor
- 29 – Flow sensor for mixed heating circuit 1
- 30 – Variable input 1
- 31 – Variable input 2
- 32 – Variable input 3
- 33 – Flow sensor for mixed heating circuit 2
- 34 – Solar panel flow sensor <sup>1)</sup>
- 35 – Solar tank sensor
- 36 – Pulse input
- 37 – Heat generator-data bus A
- 38 – Heat generator-data bus A

### Mounting into boilers

See technical documentation of boiler manufacturer.

### Wall mounting

See technical documentation »wall mounting set THETA WG«

<sup>1)</sup> Solar application only

## Wall socket MS-K



### Application:

The wall socket MS-K is used for wall mounting application of all types of standard units.

### Type

The wall-mounted connection base is intended for the sole purpose of housing the standard unit.

After plugging the standard unit into the wall socket and after finishing the electrical wiring ready for start up.

### Electrical installation

1- Break out the impressed cable inlets due to the required number and seize on top side or lower side of the wall socket according to the position of the cable channel.

Note:

Cable strain relief is prescribed if no cable duct is used.

2- Turn locking screws (1) horizontally and pull off terminal cover to the side.

3- Fix wall socket on a flat background using enclosed screws and plugs. Use drill pattern the enclosed

4- Electrical installation has to be carried out according to plant and connectivity as shown on next page.

**At non-observance the instrument will definitely be destroyed and any warranty gets lost.**

The connecting terminals of terminal blocks X7 to X10 principally may work with mains voltage according to the current operation conditions.

The wall socket is equipped completely with screwless terminals. Press lever before inserting stripped wire into terminal.

5- Attach and clamp the side terminal-covers.

6- Insert standard unit with evenly distributed pressure. The electrical connection is done by plugging the instrument into the terminals at the socket print. Lock standard unit with both quick clamping devices left and right.

### Note:

Cables with mains voltage must be installed **separate** from low voltage cables (data bus, sensors etc.). It is strictly prohibited to use **one cable** for both voltages. Use cable ducts equipped with separators, if necessary.

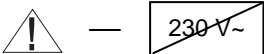

**The connecting terminals of terminal blocks X5 and X6 at the left side work with safety low voltage and must not get into contact with the mains voltage.**

# Terminal assignment

## 230 V~ Connections

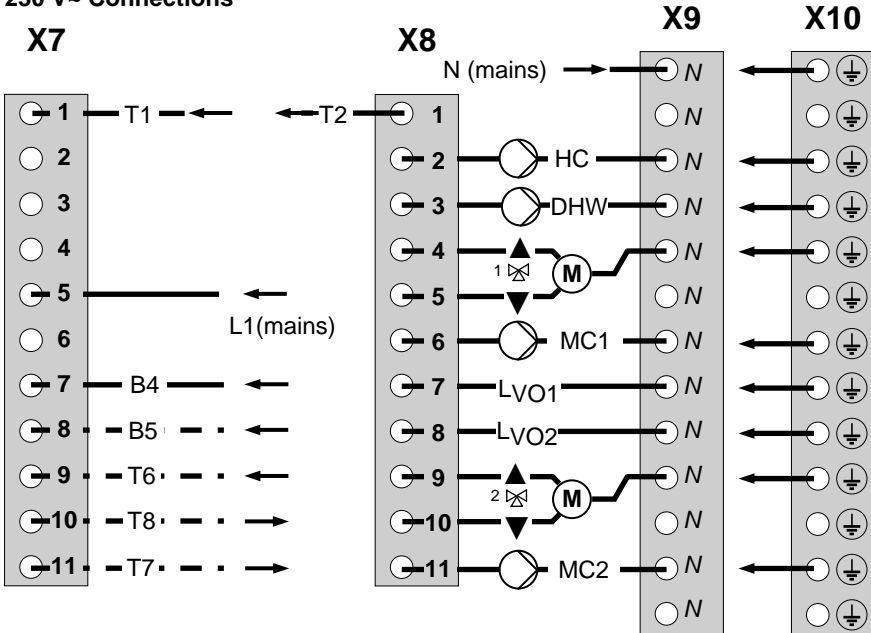

## Sensor and data bus connections

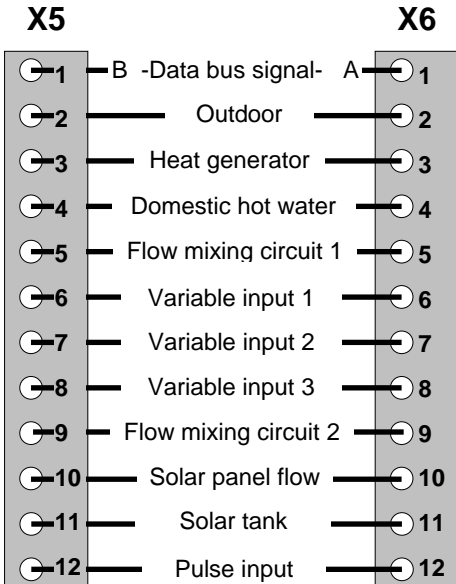

Boiler – Data bus

## Burner connections

- T1 Control terminal stage 1
- T2 Control terminal stage 1
- B4 Op. hours counter burner stage 1
- B5 Op. hours counter burner stage 2
- T6 Control terminal stage 2
- T7 Control terminal stage 2
- T8 Control terminal stage 2

- L1 Mains 230 V~ (live)
- N Mains 230 V~ (neutre)

## Pumps and actuators

- HC Pump for direct heating circuit
- DHW Domestic hot water charging pump
- MC1 Pump for mixed heating circuit 1
- MC2 Pump for mixed heating circuit 2
- 1 actuator mix. valve 1 (OPEN)
- 1 actuator mix. valve 1 (CLOSE)
- 2 actuator mix. valve 2 (OPEN)
- 2 actuator mix. valve 2 (CLOSE)
- Lvo1 Variable output 1 (live)
- Lvo2 Variable output 2 (live)



## Remote control unit RS

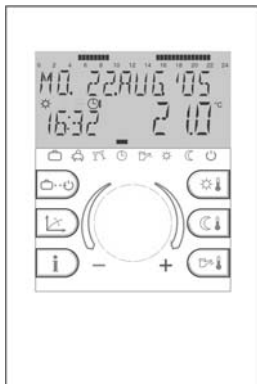

### Mounting location

- a – for applications without room sensor  
If the internal room sensor is not to be activated the RS may be mounted at any location indoors.
- b – for applications with room sensor  
The remote unit should be fixed at a height of approx. 1.20 – 1.50 m at a place most representative of all rooms. It is recommended to choose an interior wall of the coolest day room (such as entrance halls). In order to ensure sufficient air circulation at the room station, it must be mounted to the wall with a gap inbetween.

The remote unit must not be mounted

- at locations exposed to direct sunlight (seasonal variations should be taken into account)
- close to heat-producing appliances (televisions, refrigerators, wall lamps, radiators etc.)
- onto walls heated by under plaster heating pipes or chimneys.
- onto outside walls

- in corners behind curtains or shelves (due to insufficient ventilation)
- close to doors of unheated rooms (due to the influence of low temperature)
- on unsealed under-plaster wiring boxes (influence of external low temperatures due to the chimney effect of installation tubes)
- in rooms with radiators controlled by thermostatic valves (mutual influence).

### Mounting

After removing the front panel by pressing the locating lug at the lower side the socket can be mounted at the desired location using the enclosed dowel pins and screws. The cable for the bus connection has to be led through the lower cut-out of the socket.

Recommended connecting cable:

*J-Y(ST)Y 1 x 2 x 0.6mm<sup>2</sup>*

*Maximum length: 100 m*

#### Note:

For new installations use an under-plaster wiring box for perfect wiring.



Locating lug

## Terminal assignment

The wiring between remote unit and standard unit or boiler control panel has to be made by a shielded data bus cable at terminals A and B of both units. The connecting terminals **may not be changed** and have to be installed according to the labelling of the terminals A and B in the wall socket. Changing the terminals causes no displaying.

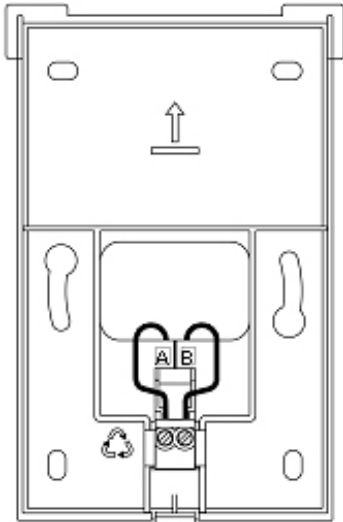

Socket (unit removed)

After completing the electrical wiring hang remote unit conclusively on top side according figure on page 9 and turn down until it clicks into the wall socket.

## Electrical connections (control unit)

See installation instructions of control unit.

## Data bus addressing

In order to guarantee a selective communication between remote units and control units it is necessary to set every remote unit in the bi-directional data bus system to the corresponding data bus address.

This concerns in the same way the coupling of control units for extension of heating circuits, which communicate on the same data bus line.

By this reason control units and remote units are equipped with **data bus addresses**.

### Data bus address (control unit)

Single control units must always have the address 10. In heating plants with several control units (maximum 5) the main controller that works on the burner gets the data bus address 10, the remaining controllers have to be set to addresses 20, 30, 40 and 50 one after the next.

### Adjustment of data bus address of the control unit

To adjust the data bus address in the control unit the corresponding specialist code must be entered in the data bus level first (see starting up the control unit).

### Adjustment of data bus address of the remote unit

The assignment between the data bus addresses of the control units and remote units is to a fixed factory preset scheme in accordance with the following table:

Control unit		Remote unit	
Function	Data bus address	Heating circuit	Data bus address
Basic control unit	10	Direct circ.(HC)	11
		MC 1	12
		MC 2	13
1. add-on unit	20	Direct circ.(HC)	21
		MC 1	22
		MC 2	23
2. add-on unit	30	Direct circ.(HC)	31
		MC 1	32
		MC 2	33
3. add-on unit	40	Direct circ.(HC)	41
		MC 1	42
		MC 2	43
4. add-on unit	50	Direct circ.(HC)	51
		MC 1	52
		MC 2	53

## Adjustment of data bus address in the remote unit

### A- First start-up

After completing the electrical installation and starting up the plant the complete segment character appears in the display of the remote unit.

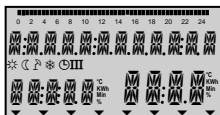

**Segment character**

Following this, the desired language can be selected in accordance with the country code (DE, GB, FR, IT, NL, ES, PT, HU, CZ, PL, RO, RU, TR, S, N, BG) and activated.

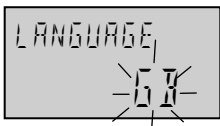

**Language**

Onto that the device identification and data bus address is displayed:

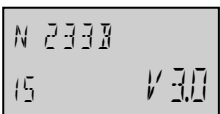

**Device identification**  
Type of control  
Software date  
Software-Version

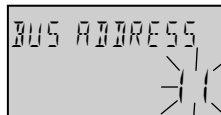

**Address adjustment**  
(See table to the left)

After setting the data bus address by means of the rotary knob and confirming by pressing the same once the number of the corresponding control unit appears automatically:

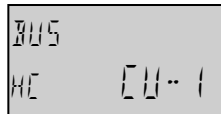

**Data bus address**  
Direct heating circuit  
Basic control unit (1)

### Important:

Double reservation of data bus addresses are not permissible and do lead automatically to troubles in the data transfer and to faulty control characteristic of the heating system.

### B – Changing data bus addresses

A data bus address can be changed subsequently as follows:

- 1 - Disconnect remote unit from data bus line (by loosening plug-in connector at the lower end)
- 2 - Plug-in connector again while pressing the rotary knob until the address adjustment appears in the display.
- 3 - Adjust new data bus address by means of the rotary knob and confirm by pressing the same once.

## Equipment

### Outdoor sensor AF (OT)



Outdoor sensor AF 200

### Mounting location

The outdoor sensor should be installed on the most exposed and coldest side of the building (north or north-west) so that it does not collect any direct sun light particularly in the morning.

**Note:** Chose the corresponding side of building due to the direction of the preferential living area.

Never mount sensor onto external heat sources such as chimneys, hot air from air shafts, sunlight or black undergrounds etc. since this will falsify the measured values considerably. The cable outlet must be directed downwards in order to avoid the intrusion of moisture.

### Electrical installation

- 1– Install sensor cable to the sensor location
- 2– Loosen lid screws and remove top
- 3– Mount open sensor case with enclosed central fixing screw. Use sealing ring! Cable outlet must be directed downwards!
- 4– Insert sensor cable. The cable insulation must be encircled by the sealing lips of cable entry.
- 5– Set up electrical connection. For the electrical installation preferably a 2-core cable with at least sectional view of  $1 \text{ mm}^2$  is recommended.

The connection is made at the screw terminal block inside the sensor case and may be changed.

- 6– Put on lid again and screw it firmly with the case. Pay attention to correct seat of sealing ring.

### Immersion sensor KVT



Options:

KVT 20/2/6 2 m cable length

Application: Boiler sensor, hot water sensor (for boiler integrated hot water tanks), return flow sensor

KVT 20/5/6 5 m cable length

Application: Hot water sensor (for add-on tanks, buffer tanks, solar collector return flow sensor etc.

### Mounting location:

In the immersion sleeve of the respective application.

### Mounting into boilers or other heat sources

Bend clutch spring to sensor top and insert sensor together with the capillary sensors of boiler thermostat (KTR), safety temperature limiter (SLT) and boiler thermometer (KTA) into the immersion sleeve. Use spring clip if necessary.

### Mounting into hot water or buffer tanks

Bend clutch spring to sensor top and insert sensor according to the instructions of the manufacturer into the dry immersion sleeve of the respective hot water tank.

### Terminal assignment

Connect sensors at the corresponding terminals of the respective control unit (see terminal diagram). The terminals may be changed.

## Flow sensor VF



Feeding sensor VF...

Options:

VF 202 2 m cable length

Application: Contact sensor for mixer controlled heating circuits onto flow- or return pipes

VF 204 4 m cable length

Application: see VF 202

### Mounting location:

Behind the mixer circuit pump, in the flow, at a minimum distance of 50 cm.

In case of use as return flow sensors:

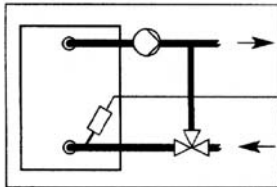

Return flow sensor

Controlled flow temperature addition by means of mixing valve

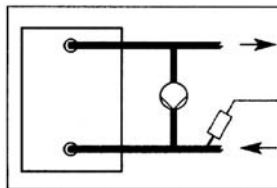

Return flow sensor

Bypass circuit by means of a bypass pump  
Boiler bypass pump

### Mounting

Clean flow or return pipe thoroughly and apply heat conducting paste.

Attach sensor on the contact place in a flush way to the tube surface by means of the enclosed clamping band.

Pay attention to firm seat!

## Terminal assignment

Connect sensors at the corresponding terminals of the respective control unit (see terminal diagram). The terminals may be changed.

## Flue gas sensor / solar panel flow sensor



Immersion sensor PT 1000/6

Options:

PT1000/6 2.5 m cable length

Application: Flue gas temperature  
Collector flow temperature

### Mounting location:

- In the flue gas tube in the minimum distance of the double tube diameter
- In the immersion sleeve of the solar collector.

### Mounting in the flue gas tube

Mount sensor clamp according to illustration below. Determine immersion depth into the core flow of the flue gas and fix sensor.

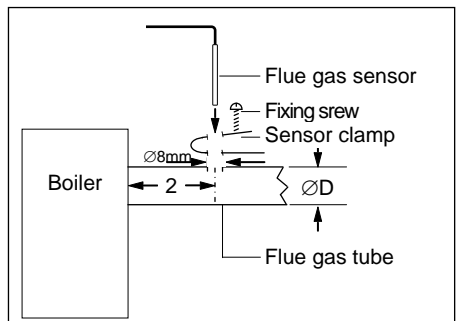

### Terminal assignment

Connect sensors at the corresponding terminals of the respective control unit (see terminal diagram). The terminals may be changed.

## Resistance values of the sensor elements versus temperature

Outdoor sensor AF 200

Heat generator/boiler sensor KVT 20  
 DHW tank sensor/buffer sensor KVT 20  
 Feeding sensor VF 202/204  
 Boiler sensor (solid fuel) KVT 20

T (°C)	R (kΩ)
- 20	1,383
- 18	1,408
- 16	1,434
- 14	1,459
- 12	1,485
- 10	1,511
- 8	1,537
- 6	1,563
- 4	1,590
- 2	1,617
± 0	1,644
2	1,671
4	1,699
6	1,727
8	1,755
10	1,783
12	1,812
14	1,840
16	1,869
18	1,898
20	1,928
25	2,002
30	2,078

T (°C)	R (kΩ)
10	1,783
12	1,812
14	1,840
16	1,869
18	1,898
20	1,928
25	2,002
30	2,078
35	2,155
40	2,234
45	2,314
50	2,395
55	2,478
60	2,563
65	2,648
70	2,735
75	2,824
80	2,914
85	3,005
90	3,098
95	3,192
100	3,287

Flue gas sensor, solar panel sensor PT1000

T (°C)	R (kΩ)	T (°C)	R (kΩ)
40	1,155	150	1,573
50	1,194	160	1,611
60	1,232	170	1,648
70	1,271	180	1,685
80	1,309	190	1,722
90	1,347	200	1,758
100	1,385	210	1,795
110	1,423	220	1,832
120	1,461	230	1,868
130	1,498	240	1,905
140	1,536	250	1,941

## Starting up the control unit

### Display test and device identification

During the first switch-on of the control unit or at return of voltage after power failure all available display segments will temporary appear:

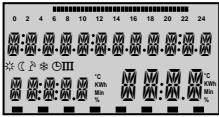

Segment character

The desired language can be selected.



Language

Onto that device identification follows:

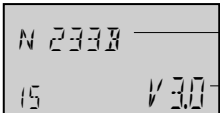

Device type

Maxcode and version number

Provided that there is not any error message, the basic display with date, time and current boiler temperature will appear in the display.

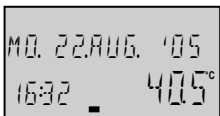

Basic Display

Date: Mon. Aug. 22, 2005  
Time: 16.32  
Temp. 40.5°C

An active summer switch-off is represented by a sunshade symbol (☀).

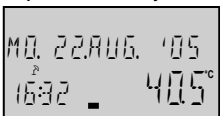

Summer switch-off active

With acting frost protection function an ice crystal symbol appears in the display (\*).

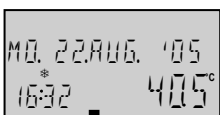



Frost protection active

## Code-Input

### Specialist code

After entering the specialist code the parameters which are certain for the heating specialist are released and can be processed according to the heating plant design.

To enter the specialist code the buttons  and  have to be pressed simultaneously for approx. 3 seconds until the request to enter the code will be displayed.

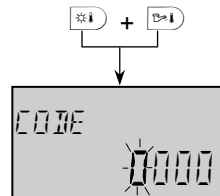

Every flashing digit can be modified with the rotary knob according to the code number and confirmed by pressing the knob once. The further digits are treated in same way.

After entering all digits correctly and confirming the last digit the specialist code is accepted by displaying *INSTALLER OK*, with wrong entry the message *CODE ERROR* will appear.

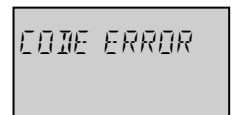
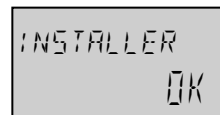

The factory preset code for the specialist is

1 2 3 4

**Note:** Contact boiler manufacturer if the factory preset specialist code is not accepted!

**Important:** Released parameters are locked again if for the duration of no further service occurs. In this case the specialist code must be entered again.

## Automatic SET-Function

This function allows to remove heating or hot water circuits from operation.

The control circuits are registered automatically, if their corresponding sensors are connected and provide acceptable measuring values. Control circuits without the corresponding sensors remain automatically without consideration.

The automatic set function will be activated after every switch-on.

## Automatical activation

Provided that the auto-set function is turned on (see *SYSTEM-Level* – parameter 14) and the initial start-up date was not yet stored, connected or disconnected sensors will be registered automatically at every switch-on of the control unit. During this time error messages of sensors (short circuit or interruption) will be suppressed.

After the initial start-up date was stored, a modified sensor configuration can only be taken over by manual activation.

## Manual activation

AUTO-SET function can be manually activated at any time by keeping the rotary knob pressed during the segment test when switching control unit on.

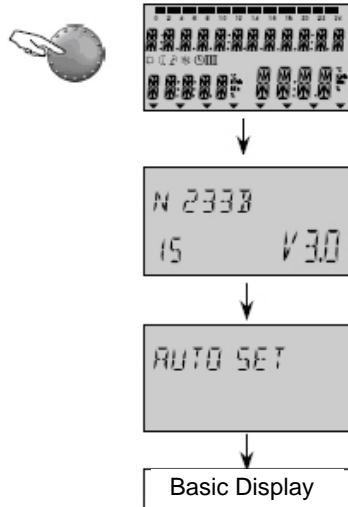



The auto set function registers the following sensors:

- Outdoor sensor
- Flow sensor 1
- Flow sensor 2
- Hot water tank sensor
- Heat generator /boiler sensor

Furthermore the auto set function is carried out only, if the control circuits which are assigned to the corresponding sensors were parameterised in the respective levels.

**For the hot water sensor:**

*HYDRAULIC Level*

Parameter 2 - Function DHW charging pump  
Setting range OFF or 1 (DHW charging pump)

**For the supply sensor 1:**

*HYDRAULIC Level*

Parameter 3 - Function mix. heating circuit 1  
Setting range OFF or 3 (mix. heating circuit)

**For the supply sensor 2:**

*HYDRAULIC Level*

Parameter 4 - Function mix. heating circuit 2  
Setting range OFF or 3 (mix. heating circuit)

**For the boiler sensor:**

*Level HEAT GENERATOR*

Parameter 1 – Type of heat generator  
Setting range OFF or 1 (1-stage-burner)

With that a programmed parameterisation will not be changed again, the current values will be checked before. A modification is carried out only if one of the adjustments listed above is given. In this way the auto set function for example never can cancel a return flow increase of mixer heating circuit 2, or can function it to a mixer heating circuit.

## Alarm messages

In order to set up a precise diagnosis in the case of malfunction the control system is equipped with an extensive alarm message system. An occurring error is always announced in the display of the corresponding basic control and stored.

There are five different categories of alarm messages:

### 1 - Sensor alarm messages

Sensor values which are not in their respective measuring range will either be sensor breaks or sensor short circuits. They appear with an error message according to their use.

### 2 - Boiler alarm messages

These messages depend on the actual switching conditions. They appear with the corresponding error message, depending on the version and allocation.

### 3 - Logical alarm messages

These messages will react on the actual control result. They appear with the corresponding error message, depending on the version and allocation.

### 4 - Bus alarm messages

These messages display address problems such as double addresses or not recognizing addresses within the data bus system. They appear with the corresponding error message, depending on the version and allocation.

### 5 - Alarm messages from boiler control

These alarm messages are transmitted by the boiler control system via a data interface and are displayed or stored in the control unit. More detailed information regarding alarm messages can be found in the boiler documentation.

The displaying characters and further processing of the logical faults can be enabled or suppressed by a corresponding parameterization in THETA (see **SYSTEM** level-parameter 13 logical error message).

### Further processing in case of alarm messages:

- Alarms will be indicated in the basic display of the control unit
- System errors appear in the information level beside the corresponding information
- Alarm messages are loaded into a alarm message log (see description below)
- Alarm messages activate in case of corresponding parameterisation an alarm output for optical or audible signalers.
- Alarm messages are transmitted via data bus to corresponding gateways.

### Table of alarm messages:

Sensors and variable inputs:

Designation	Alarm cause	Code
Outdoor sensor	break	10-0
Outdoor sensor	short circuit	10-1
Boiler sensor	break	11-0
Boiler sensor	short circuit	11-1
Flow sensor 1	break	12-0
Flow sensor 1	short circuit	12-1
DHW sensor	break	13-0
DHW sensor	short circuit	13-1
Variable input 2	break	14-0
Variable input 2	short circuit	14-1
Variable input 2	alarm	14-7
Variable input 3	break	15-0
Variable input 3	short circuit	15-1
Variable input 3	alarm	15-7
Variable input 1	break	16-0
Variable input 1	short circuit	16-1
Variable input 1	alarm	16-7
Sol.panel/buffer	break	17-0
Sol.panel/buffer	short circuit	17-1

Designation	Alarm cause	Code
Flow sensor 2	break	18-0
Flow sensor 2	short circuit	18-1
Solar panel sensor	break	19-0
Solar panel sensor	short circuit	19-1

### **Heat generator:**

Burner 1	not OFF	30-2
Burner 1	not ON	30-3
Burner 2	not OFF	31-2
Burner 2	not ON	31-3
Flue gas	exceeded	33-5
Flue gas	STL triggered	33-8

### **Temperatures:**

Heat generator	not reached	50-4
DHW	not reached	51-4
Flow mixer circuit 1	not reached	52-4
Flow mixer circuit 2	not reached	53-4
Room HC	not reached	54-4
Room-mix. circuit 1	not reached	55-4
Room-mix. circuit 2	not reached	56-4

### **Data bus errors**

Activity	no H-GEN-signal	70-6
Activity	no master	70-8

### **Condensing boiler control error**

Malfunction	locking	XXX
Malfunction	blocking	XXX

(display option dependent upon boiler control system)

## **Malfunction log**

The control unit has a malfunction log in which a maximum of 20 alarm messages can be saved. The alarm messages are displayed with date, time and malfunction type (error number). The query is carried out in the sequence of the entered alarm messages in the level *ALARM*.

The last (= most recent) alarm message is in first position (No. 01); the previous alarm messages are shifted down by a position upon each new alarm message. The last (20.) alarm message is deleted when a new message appears.

Alarm messages from condensing boiler controls represent a special feature. If enabled (SYSTEM parameters 27 and 28), these will be written into an own alarm message memory.

**Note:** Only the last 5 alarm messages will be displayed in *ALARM* level in the room devices. System parameters 27 and 28 are **not** available for room units!

## **Heating system information**

### **Heating system temperatures**

After entering of the information level by means of the information key  a query of all available plant and system temperatures can be made using the rotary pushbutton.

Provided that in the following table under the column **Display Value** a nominal value is listed, it will appear when pressing the rotary push-button.

The following information appear only under the indicated display conditions. Some displays are not available and are skipped according to the respective type of control.

Information	Displayed value	Remarks	Application
Outdoor temp. (1)	Average value / current value	Outside sensor connected	
Outdoor temp. (1)	Min-max-value from 0.00 to 24.00 h)	Outside sensor connected	
Outdoor temp. 2	Average value / current value	Outdoor sensor 2 at var. input	
Outdoor temp. 2	Min-max-value from 0.00 to 24.00 h)	Outdoor sensor 2 at var. input	
EM-SET (Energy Management setpoint value)	Maximum warm water and maximum heating circuit setpoint value in the system	Installer level	
Heat generator (1)	Nominal/actual value	Only if heat generator is defined	(..2..)
Heat generator 2	Nominal/actual value	Sensor BS 2 at variable input	(..2..)
Return flow (b. contr.)	Actual value	Return flow sensor connected at boiler control	(..C..)
Flue gas (b. contr.)	Actual value	Flue gas sensor connected at boiler control	(..C..)
Return flow	Nominal/actual value	Return flow sensor at var. input and return temp. increasing activated	
External blocking	Block mode ON, OFF	Ext. blocking at variable input	
Flue gas	Limit value/ actual value	Flue gas sensor at variable input	(..2..)
Hot water tank (1)	Nominal/actual value	Only with hot water tank	(..B..)
Hot water tank 2	Nominal/actual value	Hot water sensor 2 at var. input	(..B..)
Hot water thermostat	Charging status ON/OFF	Instead of an electronic sensor	(..B..)
Heat requirement via contact (VI-1)	Requirement ON/OFF	Switching contact at variable input	
Heat requirement via contact (VI-2)	Requirement ON/OFF	Switching contact at variable input	
Heat requirement via contact (VI-3)	Requirement ON/OFF	Switching contact at variable input	
Flow Mixed circuit 1	Nominal/actual value	Flow sensor mix. heating circuit 1 connected	(..3..)
Flow Mixed circuit 2	Nominal/actual value	Flow sensor mix. heating circuit 2 connected	(..33..)

Ambient temper. Direct heat. circuit	Nominal/actual value	Remote control necessary	(..2..)
Ambient temper. Mix. heat. circuit 1	Nominal/actual value	Remote control necessary	(..3..)
Ambient temper. Mix. heat. circuit 2	Nominal/actual value	Remote control necessary	(..33..)
Thermostat function Direct heat. circuit	THERMOSTAT DC	Room thermostat function activated OFF = no room temperature limit	(..2..)
Thermostat function Mixed circuit 1	THERMOSTAT MC1	Room thermostat function activated OFF = no room temperature limit	(..3..)
Thermostat function Mixed circuit 2	THERMOSTAT MC2	Room thermostat function activated OFF = no room temperature limit	(..33..)
Solid fuel boiler upper buffer sensor	Actual value Nominal/actual value	Solid fuel charging pump at var. output Buffer charging pump at var. output	(Type ..VV..) (Type ..VV..)
Lower buffer sensor Solar panel sensor	Nominal/actual value Actual value	Buffer sensor 2 at variable input Solar pump at variable output	(Type ..VV..) (Type ..VV..)
Solar tank	Actual value	Solar pump at variable output	(Type ..VV..)
Solar panel return flow sensor	Actual value	Solar pump at variable output Return flow sensor at var. input	(Type ..VV..)

### Operating states

After entering the information level by means of the information key  all available operating states and usage data such as counter readings, specified

performance data etc. can be requested after each other by turning the rotary push-button anti-clockwise.

Information	Display (Example)	Function	Application
Status direct circuit	<i>AUTO-P1 ECO</i> <i>HC ON</i>	Operating mode / ☹-program/mode status of heating pump	(..2..)
Status Mixed circuit 1	<i>AUTO-P1 ECO</i> <i>MC1 ON</i>	Operating mode / ☹-program/mode status of heating pump	(..3..)
Status actuator Mix. valve-1	<i>MIX. VALVE-1</i> <i>OPEN</i>	Display of direction OPEN-STOP-CLOSE	(..3..)
Status Mixed circuit 2	<i>AUTO-P1 ECO</i> <i>MC2 ON</i>	Operating mode / ☹-program/mode status of heating pump	(..33..)
Status actuator Mix. valve-2	<i>MIX. VALVE-2</i> <i>STOP</i>	Display of direction OPEN-STOP-CLOSE	(..33..)
Status heat gener. stage 1	<i>HEAT GENER.</i> <i>ON</i>	Switching state of heat generator Single stage or stage 1 (2-stage)	(..2..)
Status heat gener. stage 2	<i>HEAT GENER.</i> <i>ST-2 OFF</i>	Switching state of heat generator Stage 2	(..22..)
Status modulating heat gener.	<i>MODULATION</i> <i>57% 60%</i>	Modulating single stage heat generator, nominal and actual value	(Type ..VV..)

Status DHW circuit	<i>AUTO-P1 ECO</i> <i>DHW ON</i>	Operating mode / $\text{D}$ -program/mode status of DHW charging pump	(..B..)
Function & status Direct circuit pump	<i>OUTPUT HC-P</i> <i>EO ON</i>	Information about the assigned function and switching state of pump	(..2..)
Function & status Variable output 1	<i>OUTPUT VO-1</i> <i>SOP OFF</i>	Information about the assigned function and switching state of var. output 1	(Type ..VV..)
Function & status Variable output 2	<i>OUTPUT VO-2</i> <i>SOP OFF</i>	Information about the assigned function and switching state of var. output 2	(Type ..VV..)
Activations heat generator (St.1)	<i>NR OF STARTS</i> <i>1234 (ST-1)</i>	Accumulated number of starts Single stage or stage 1 (2-stage)	(..2...,..22..)
Operating hours heat generator (St.1)	<i>OPER. HOURS</i> <i>246</i>	Accumulated operating hours Single stage or stage 1 (2-stage)	(..3..)
Activations heat generator St. 2	<i>NR OF STARTS</i> <i>268</i>	Accumulated number of starts Stage 2	(..3..)
Operating hours heat generator St. 2	<i>OPER. HOURS</i> <i>45 ST-2</i>	Accumulated operating hours Stage 2	(..33..)
Test temp. sensor for test purpose	<i>INFO-TEMP.</i> <i>50°C</i>	Ext. sensor for test purpose at variable input	(..33..)
Operating mode ext. modem control	<i>MODEM</i> <i>AUTO</i>	Actual operating mode of external modem at variable input	(..2..)
Actual solar power	<i>HEAT POWER</i> <i>43 KW SOL</i>	Act. power of the solar system in kW	(Type ..VV..)
Solar energy balance	<i>HEAT CONS.</i> <i>2468 KWh SOL</i>	Accumulated thermal capacity of the solar system in kWh	(Type ..VV..)
Activations solar panel pump	<i>NR OF STARTS</i> <i>296 SOL</i>	Accumulated number of starts of the solar panel pump	(Type ..VV..)
Operating hours solar panel pump	<i>OPER. HOURS</i> <i>478 SOL</i>	Accumulated operating hours of the solar panel pump	(Type ..VV..)

### Application:

- (..2..) 1-stage heat generator
- (..22..) 2-stage heat generator
- (..3..) with 1 mixing circuit
- (..33..) with 2 mixing circuits
- (..B..) DHW circuit
- (..VV..) with 2 variable outputs
- (C, OT) high efficiency condensing boilers

# Level synoptic

**Entry into the level selection:** Hold rotary push-button pressed for approx. 3 seconds - automatic call of time programs  
 Select required level via rotary push-button and confirm, enter code if necessary

PARAMETER NO.	Programming		Configuration	
	TIME-DATE	TIME PROGRAMS	HYDRAULIC	SYSTEM-PARAMETERS
1	Time (Min/hrs)	see programming of time-programs		Language
2	Year		Output SOL-P	Enable time programs
3	Day-Month		Output MC1	Control mode
4	Change Su-Wi-time		Output MC1	Summer switch-off
5			Output HC	System frost protection
6			Output VA-1	Heat requiring contact VI-1
7			Output VA-2	Heat requiring contact VI-2
8		Input VI-1	Heat requiring contact VI-3	
9		Input VI-2	Climate zone	
10		Input VI-3	Type of building	
11		Indirect raising of return flow	Time for autom. exit	
12			Anti blocking protection	
13			Logical alarms	
14			Automatic Set -Function	
15				
16				
17				
18			Release cycle temp.	
19			Frost protection mode	
21				
23			Locking code for user level	
24			Scaling accord. to Fahrenheit	
25				
26				
27			Alarm messages boiler control	
28			Alarm messages 2	
29				
34				
35				
37				
			Reset to factory preset	

PARAMETER NO.	Parameterization (Heating circuits, controlled systems)					
	DHW (.B.)	UNMIXED CIRC. HC (.2.)	MIXED CIRCUI T 1 MC1 (.3.)	MIXED CIRCUI T 2 MC2 (.33.)	HEAT GENERATOR (.2., .22.)	COMMON FLOW SENSOR
1	ECO DHW temperature	Reduced mode	Reduced mode	Reduced mode	Type H-Gen	P-band Xp SVLF control
2	Legion.prot. (day)	Heating system (exponent)	Heating system (exponent)	Heating system (exponent)	Start-up protection	Sample time Ta SVLF control
3	Legion.prot. (time)	Enable room influence	Enable room influence	Enable room influence	Heat generator mini.temp.limit	I-band Tn SVLF control
4	Legion.prot. (temp.)	Room factor	Room factor	Room factor	Maximum temp. limit	
5	DHW sensor type	Adaptation heat. charact.	Adaptation heat. charact.	Adaptation heat. charact.	Minimum temp. limiting mode	
6	DHW max. temp. limit	Switch-on optimization	Switch-on optimization	Switch-on optimization	Heat generator sensor mode	
7	DHW operat. mode	Heating limit	Heating limit	Heating limit	Minimum burner run time	
8	Discharge protection	Room frost protection limit	Room frost protection limit	Room frost protection limit	Burner switch. differential I	
9	Temperature parallel shift	Room thermostat function	Room thermostat function	Room thermostat function	Burner switch. differential II	
10	DHW switching differential	Outdoor sensor assignment	Outdoor sensor assignment	Outdoor sensor assignment	Time delay stage II	
11	Ext. run time SOL-P	Constant temp. setpoint	Constant temp. setpoint	Constant temp. setpoint	Enabling mode stage II	
12	Time program CIR.	Minim. temp. limit HC	Minim. temp. limit HC	Minim. temp. limit HC	DHW charging mode stage II	
13	Econ. interval CIR. (break)	Maxim. temp. limit HC	Maxim. temp. limit HC	Maxim. temp. limit HC	Flow time boiler pump	
14	Econ. interval CIR. (period)	Heat generator parallel shift	Heat generator parallel shift	Heat generator parallel shift	Extended run time boiler pump	
15		Extended pump run time	Extended pump run time	Extended pump run time	Ext. run time feed pump	
16		Compos. floor drying function	Compos. floor drying function	Compos. floor drying function	Flue gas temp. monitoring	
17	Behaviour H-GEN ext. run time		Return flow max. temp. limit	Return flow max. temp. limit	Flue gas temp. limit	
18						
19						
21			Valve run time	Valve run time		
23		Room control P-range	Room control P-range	Room control P-range		
24		Room control Adaptation time	Room control Adaptation time	Room control Adaptation time		
25		Operating mode Holiday	Operating mode Holiday	Operating mode Holiday	Outdoor temp. locking	
26					Basic load parallel shift	
27					HC mini temp. limit	
28					Diff. Min. lim. HC	
29					H-GEN forced discharge	
34					Heating power limiting	
35					DHW power limiting	
37					Oper. hours counter	
					Reset stage I	
		HC name	HC name	HC name	Reset stage II	



Parameters without background colour: accessible to the user

Parameters with grey background: Installer parameter, only accessible with correct installer code.

Parameterization					Add-on modules	Communic.	Service				Par.Nr.
Return flow temperature raising	Solar (Type ..VV..)	Solid fuel (Type ..VV..)	Buffer (Type ..VV..)	Cascade control	.....	Data bus	Relay test	Alarms	Alarms 2	Sensor calibration	
Return temp. setpoint	Switch-on differ. collector-buffer	Minimum temp. limit	Minimum temp. limit	Switching differential	refer to the add-on module documentation	Bus address Basic unit	Heat generator.	1	1	Type	1
Switch-off differential	Switch-off differ. collector-buffer	Maximum temp. limit	Maximum temp. limit	Time delay ascend. seq.		Bus access RS HC	Heat. pump (HC)	2	2	Outdoor sensor	2
Extended pump run time	Min. run time solar pump	Switch-on differ. boiler-buffer	Heat generator parallel shift	Time delay descend. seq.		Bus access RS MC1	Heat. pump MC 1	3	3	Boiler sensor	3
	Max. solar panel temp.	Switch-off diff. boiler-buffer	Switching differential	Sequential switch-over pwr.		Bus access RS MC2	Actuator Mix.valve 1	4	4	DHW tank sensor	4
	Max. buffer temperature	Inhibition heat generator	Forced heat dissipation	Reverse boiler sequence			Heat. pump MC 2	5	5	Flow sensor MC1	5
	Solar operating mode		Drain function Switch-on differ.	Leading stage			Actuator Mix.valve 2	6	6	Flow sensor MC2	6
	Inhibition heat generator		Drain function Switch-off differ.	Peak load boiler			DHW charging pump	7	7	Solar panel sensor	7
	Change priority/parallel mode		Buffer start-up protection	Changeover			Output VA-1	8	8	Buffer sensor	8
	Solar energy balance		Buffer discharge protection	DHW quick activation			Output VA-2	9	9	Sensor VI-1	9
	Reset sol. energy balance		Buffer operating mode					10	10	Sensor VI-2	10
	Volume flow solar fluid		Ext. run time BULP				11	11	Sensor VI-3	11	
	Fluid density						12	12		12	
	Fluid heat capacity						13	13		13	
	Final switch-off temperature						14	14		14	
	Test cycle sol.load.sw.						15	15		15	
	Change over temperature						16	16		16	
							17	17		17	
							18	18		18	
							19	19		19	
							20	20		20	
										21	
										22	
										23	
										24	
										25	
										26	
										27	
										28	
										29	
										36	
										37	

# Synoptic of the specialist parameters and control options

## HYDRAULIC Level

The parameters of this level refer to the general hydraulic system of the heating plant as well as to the functionality and configuration of the programmable inputs and outputs for the corresponding plant components. They are not available in room stations!

Parameter	Designation	Setting range / Setting values	Factory preset	Individual setting
02	DHW charging pump output (Type ..B..)	OFF No function 1 DHW charging pump 4 DHW circulation pump 5 DHW electrical heating element	1	
03	Mixing circuit 1 (MC1) output (Type ..3..)	OFF No function 2 Direct circuit (outdoor temp. contr.) 3 Mixing circuit (outdoor temp. contr.) 6 Constant temp. contr. 7 Fixed value contr. 8 Raising return temp.	3	
04	Mixing circuit 2 (MC1) output (Type ..33..)	Setting range and assignment see parameter 03	3	
05	Direct circuit 1 (HC) output	OFF No function 2 Direct circuit pump 4 DHW circulation pump 5 DHW electrical heating element 6 Constant temperature control 10 Feed pump 11 Boiler circuit pump 1 12 Boiler circuit pump 2 13 Alarm output 14 Timer 15 Solar charging pump (Type ..VV..) 21 Parall. H-GEN-clearance 27 Hydraulic buffer release	2	
06	Variable output 1 (Type ..VV..)	OFF No function 4 DHW circulation pump 5 DHW electrical heating element 9 Boiler return pump 10 Feed pump 11 Boiler circuit pump 1 12 Boiler circuit pump 2 13 Alarm output 15 Solar charging pump 16 Buffer charging pump 17 Solid fuel boiler pump 19 Solar change over charging valve 20 Solar forced heat removal 21 Parall. H-GEN-clearance 26 Primary pump 27 Hydraulic buffer release	OFF	
07	Variable output 2 (Type ..VV..)	Setting range and assignment see parameter 06	OFF	
08	Variable input 1	OFF No function 1 Outdoor sensor 2 2 Boiler sensor 2 3 DHW tank sensor 2 4 Buffer sensor 2 5 Heat requirement contact 6 External alarm input 7 Return flow max. temp. limit (MC1) 8 Return flow max. temp. limit (MC2) 9 Return sensor (bypass pump) 10 External blocking (heat generator) 11 External switching modem 12 External information 13 Common flow sensor		

08	Variable input 1	14 Solar panel return sensor 16 Flue gas sensor 17 Boiler sensor (solid fuel) 18 Solid fuel buffer sensor 19 Buffer sensor 1	OFF	
09	Variable input 2 (Type ..VV..)	Setting range and assignment see parameter 08 without parameter 16 (flue gas sensor)	OFF	
10	Variable input 3 (Type ..VV..)	Setting range and assignment see parameter 08 without parameter 16 (flue gas sensor)	OFF	
11	Indirect raising of return temperature via mixing valve	OFF, ON (only Type ..3.., ..33..)	OFF	

## SYSTEM Level

The parameters in this level refer to the general limiting parameters and setting values in the heating system to be used.

Parameter	Designation	Setting range / Setting values	Factory preset	Individual setting
LANGUAGE	Language selection	DE German CZ Czech GB English PL Polish FR French RO Romanian IT Italian RU Russian NL Dutch TR Turkish ES Spanish S Swedish PT Portuguese N Norwegian HU Hungarian BG Bulgarian	DE	
TIME PROGRAM	Number of enabled time programs	P1 Only one time program enabled P1-P3 Three time programs enabled	P1	
CONTROL MODE	Enabling of separate control mode setting (room temp. specific. and operat. modes)	1 Common setting for all heating circuits 2 Individual setting for every heating circuit	1	
SUMMER		OFF no function System frost protection...30 °C Switch-off at set value	20 °C	
05	System frost protection temperature	OFF no function -20°C...Summer switch-off Frost protection at set value	3 °C	
06	Heat requiring contact at VI-1	1 Direct circuit (HC) 2 Mixed circuit 1 3 Mixed circuit 2 4 DHW ALL All circuits	1	
07	Heat requiring contact at VI-2 (Type .. (Type ..VV..)	Settings see parameter 06	1	
08	Heat requiring contact at VI-2 (Type .. (Type ..VV..)	Settings see parameter 06	1	
09	Climate zone	-20...0 °C	-12 °C	
10	Type of building	1 light construction 2 medium construction 3 heavy construction	2	
11	Time for automatic exit (return to basic display)	OFF No automatic return 0.5...5 min Automatic return to the basic display according to the set time	2 Min	
12	Pump and mix valve forced operation (Anti-blocking protection)	ON active OFF not active	ON	
13	Logical malfunction messages	OFF no display ON Display active	OFF	
14	Automatic SET-Function	OFF automat. sensor recognition deactivated ON automat. sensor recognition activated	OFF	
18	Release cycle temperature	OFF cycle temperatures blocked ON cycle temperatures released	ON	

19	Frost protection mode	OFF permafrost protection according to adjustment in parameter 05- plant frost protection 0.5...60 min cyclic operation	OFF	
23	Anti-blocking for protection	OFF (0000) no block ON (0001...9999) block	OFF	
24	Temperature display in °Fahrenheit	OFF display in °C and K ON display in °F	OFF	
27*	Alarm messages system handling Automatic boiler control	1 Shown on display screen only 2 Message from system interlocks 3 Messages from interlocks and blockages into the system 4 Message from interlocks, blockages and warnings into the system	OFF	
28	Alarm message memory 2	OFF, ON	OFF	
RESET	Reset to factory preset	in dependence on access code only to released parameters		

\* Function dependent upon support from boiler control system

## DOMESTIC HOT WATER (Type ..B..) Level

This level comprises all parameters which are necessary to program the DHW circuit with the exception of the operating time programs.

Parameter	Designation	Setting range / Setting values	Factory preset	Individual setting
DHW NIGHT	Hot water economy temperature	5 °C ... DHW maximum temperature	40 °C	
LEGION. PROT. DAY	Day for legionella protection	OFF No legionella protection Mo...Su Legionella protection on the specified day ALL Legionella protection every weekday	OFF	
03	Time for legionella protection	00:00...23:00 hour	02:00	
04	Temperature for legionella protection	10 °C ... DHW maximum temperature	65 °C	
05	Type of DHW temperature measurement	1 electronic temperature sensor 2 mechanical thermostat	1	
06	DHW- temperature limit	20 °C ... maximum boiler temperature	65 °C	
07	DHW operating mode	1 parallel mode 2 Priority mode 3 Conditional priority 4 Weather responsive parallel mode 5 Priority mode with intermediate heating 6 Priority-separation circuit 7 External operation	2	
08	DHW tank discharge protection	OFF No discharge protection ON Discharge protection activated	ON	
09	Boiler parallel shift during DHW charging	0 ... 50 K; Difference between the DHW charging temperature and DHW setpoint	15 K	
10	DHW switching differential	2 ... 20 K; Amount of DHW switching differential, symmetrical to the DHW setpoint	5 K	
11	DHW charging pump Extended running time	0 ... 60 Min	5 Min	

12	Time programm circulation pump	AUTO - Active DHW time program 1 - P1, direct heating circuit 2 - P2, direct heating circuit 3 - P3, direct heating circuit 4 - P1, mixing circuit 1 5 - P2, mixing circuit 1 6 - P3, mixing circuit 1 7 - P1, mixing circuit 2 8 - P2, mixing circuit 2 9 - P3, mixing circuit 2 10 - P1, DHW circuit 11 - P2, DHW circuit 12 - P3, DHW circuit	<b>AUTO</b>	
13	Economy intervall - cir. pump (no pulse period)	0 Min ... setpoint of parameter 14; time of circulation pump stop	<b>5 Min</b>	
14	Economy intervall - cir. pump (Period duration)	1... 60 Min Duration = shutdown time + operating time	<b>20 Min</b>	
17	Behaviour of heat generator during the extended run time	AUTO - Setpoint value to H-GEN as required OFF - H-GEN off	<b>AUTO</b>	

**Level DIRECT CIRCUIT (2.., 22..)**  
**MIXING CIRCUIT 1 (..3..)**  
**MIXING CIRCUIT 2 (..33..)**

This level contains all necessary parameters for the programming of the direct (unmixed) and/or the mixed heating circuits with the exception of the operating times programs.

Parameter	Designation	Setting range / Setting values	Factory preset	Individual setting
RED. HEATING	Type of reduced mode	ECO - Switch-off mode (frost protection) RED - Reduced mode	<b>ECO</b>	
HEAT. SYSTEM	Heating system (exponent)	1,00 ... 10,00	<b>HC =1.30</b> <b>MC =1.10</b>	
03	Room influence (with room unit )	OFF Room sensor deactivated 1 Room sensor enabled 2 Room sensor enabled, operation of room control unit blocked only display mode (room temp.) 3	<b>OFF</b>	
04	Room factor	OFF, 10 ... 500 %, RC (only room control)	<b>OFF</b>	
05	Adaptation heating curve	OFF, ON	<b>OFF</b>	
06	Optimmization (start)	OFF, 1 ... 16 h	<b>OFF</b>	
07	Heating limit	OFF, 0.5 ... 40 K	<b>OFF</b>	
08	Room frost protection limit	5 ... 30 °C	<b>10 °C</b>	
09	Room thermostat function	OFF, 0.5 ... 5 K	<b>OFF</b>	
10	Outdoor sensor assignment (only if VI n = out.sensor 2)	0 Control to mean value of out.sensor 1 + 2 1 Control to out.sensor 1 only 2 Control to out.sensor 2 only	<b>0</b>	
11	Constant temperature setpoint	10... 95 °C (only if output has been set to constant (CC) or fixed value control (FR))	<b>20 °C</b>	
12	Minimum flow temperature limit	10 °C ... Maximum temperature limit (Parameter 13)	<b>20 °C</b>	
13	Maximum temperature limit	Minimum temperature limit (parameter 12) ... maximum temperature limit H-GEN (H-GEN-parameter 04)	<b>75 °C</b>	

14	Heating circuit parallel shift	-5 ... 20 K	<b>HC=0</b> <b>MC=4</b>	
15	Heating pump (MC1, MC2) extended running time	0 ... 60 Min	<b>5 Min</b>	
16	Screed function (profile drying) (With HC only if the relevant circuit is enabled exclusively)	OFF Function switched off 1 Function heating 2 Occupation suitable heating 3 Function and occupation suitable heating	<b>OFF</b>	
21	Valve run time (only for MC1 and MC2)	10...600	<b>120</b>	
23*	P-band room control	1...100 %/K	<b>8</b>	
24*	I-band Tn room control	5...240 Min.	<b>35</b>	
25	Operating mode Holiday	STBY, RED	<b>STBY</b>	
HC-name	Heating circuit name	00000 ... ZZZZZ	<b>empty</b>	

\* only if remote unit is room controller (PARAMETER 04 = RC)

## HEAT GENERATOR LEVEL (2..., 22...)

The parameters in this level refer to the type of the relevant heat generator and to the corresponding specific control functions.

Parameter	Designation	Setting range / Setting values	Factory preset	Individual setting
01	Heat generator type	OFF without heat generator 1 Oil/Gas 1 stage (...2..) 2 Oil/Gas 2 stage (...22..) 3 Oil/Gas 2 x 1 stage (...22..) 4 variable burner 5 Automatic boiler control (...C../.OT..)	<b>1</b>	
02*	Start-up protection	OFF no start-up protection 1 Start-up protection on minim. temp. limit 2 Start-up protection on outdoor reference 3 Start up protection separated	<b>1</b>	
03*	Heat generator minimum temperature limit	5 °C ... Maximum temperature limit	<b>38 °C</b>	
04*	Heat generator maximum temperature limit	Minimum limit ... Set limit maximum limit H-GEN	<b>80 °C</b>	
05*	Heat generator minimum temperature limiting mode	1 Minimum temperature limit at heat requirement 2 Restricted minimum temp. limit 3 Permanent minimum temp. limit	<b>1</b>	
06*	Heat generator sensor mode	1 Burner switch off in case of defect 2 External Burner switch off 3 Burner enabling in case of defect <b>!!!Consider warnings!!!</b>	<b>1</b>	
07*	Minimum burner run time	0 ... 20 Min	<b>2 Min</b>	
08*	Burner switching differential I (SD I)	1-stage: 2 ... 30 K 2-stage: 2 ... (SDII - 0,5K)	<b>6 K</b>	
09*	Burner switching differential II (SD II) (...22..)	(SD I + 0,5 K) ... 30 K	<b>8 K</b>	
10*	Time delay stage 2 (...22..)	0 ... 60 min (0 = 10 Sec)	<b>0</b>	
11*	Enabling mode stage II (...22..)	1 Unlimited enabling during start-up release 2 Time out during start-up release	<b>2</b>	
12*	DHW charging mode stage 1/2 (...22..)	1 DHW charging with delayed enabling of stage 2 2 unlimited DHW charging stage 2 3 DHW charging with stage 1 only	<b>1</b>	

13*	Flow time boiler circuit pump/parallel. heat generator release	0 ... 10 Min	<b>0 Min</b>	
14*	Extended run time boiler circuit pump	0 ... 60 Min	<b>2 Min</b>	
15*	Extended run time feed pump or primary pump	0 ... 60 Min	<b>2 Min</b>	
16*	Flue gas temperature monitoring	OFF displays only flue gas temperature 0 ... 60 min Heat generator blockage in case of exceeding limit for the set time SLT Heat generator blockage in case of exceeding limit	<b>OFF</b>	
17*	Flue gas temperature limit	50 ... 500 °C	<b>200°C</b>	
25	Outdoor temp. locking	OFF, -20...+30 °C	<b>OFF</b>	
26	Basic load parallel shift (only when used in cascade mode)	0...60 K	<b>10 K</b>	
27*	Heat circuits minimum temperature limit	5 °C...KT <sub>min</sub> (only if start up release is separated - Parameter 02 = 3)	<b>36 °C</b>	
28*	Switching differential Heat circuits minimum temperature limit	2 K...20 K (only if start up release is separated - Parameter 02 = 3)	<b>4 K</b>	
29	H-GEN forced discharge	OFF no function 1 Into DHW tank 2 Into heating circuits 3 Discharge in buffer tank	<b>OFF</b>	
34*	Heating power limiting	50 ... 50 ... 100%	<b>100%</b>	
35*	Hot water power limiting	50 ... 100%	<b>100%</b>	
37	Operating hours counter	OFF AUTO 1 feedback only 2 free counter	<b>AUTO</b>	
RESET ST-1	Reset oper. hours / starts stage 1	SET	-	
RESET ST-2	Reset oper. hours / starts stage 2	SET	-	

\* Settings available depend up the type of intelligent boiler control or are preset according to the limit values of the boiler control system.

## RAISING RETURN TEMPERATURE Level

The parameters in this level refer to the special settings to increase the return temperature of heat generators. Enabling occurs only following activation in the **HYDRAULIC** level

Parameter	Designation	Setting range / Setting values	Factory preset	Individual setting
01	Return flow limiting setpoint	10 ... 95 °C	<b>20 °C</b>	
02	Switch-off differential	1 ... 20 K	<b>2 K</b>	
03	Extended run time (pump)	0 ... 60 Min	<b>1 Min</b>	

## SOLAR Level (..VV..)

The parameters in this level refer to the special settings for solar energy application. Enabling occurs only following activation in the *HYDRAULIC* level.

Parameter	Designation	Setting range / Setting values	Factory preset	Individual setting
01	Switch-on differential	(Switch-off differential +3 K) ... 30 K	<b>10 K</b>	
02	Switch-off differential	2 K ... (Switch-on differential -3 K)	<b>5 K</b>	
03	Minimum run time of solar panel pump	0 ... 60 Min	<b>3 Min</b>	
04	Maximum temperature limit of solar panel	70 ... 210 °C	<b>120 °C</b>	
05	Maximum temperature limit solar buffer	20 ... 110 °C	<b>75 °C</b>	
06	Solar operating mode	1 Priority mode 2 parallel mode 3 Priority mode DHW 4 Priority mode buffer	<b>2</b>	
07	Inhibition heat generator	OFF, 0,5 ... 24 h (Only in priority mode - Parameter 6 = 1, 3, 4)	<b>OFF</b>	
08	Change priority/parallel mode	OFF, 1 ... 30 K (only in priority mode and act. cyclic block)	<b>OFF</b>	
09	Solar energy balance	OFF No accounting 1 Accounting via flow calculation 2 Accounting via pulse processing	<b>OFF</b>	
RESET SOLAR	Reset solar energy balance	Reset: SET by pushing the rotary push-button (only if solar heat balance is enabled)	-	
11	Volume flow	0,0 ... 30 l/Min or liter/impulse (only if solar heat balance is enabled)	<b>0,0 l/Min</b>	
12	Fluid density	0,8 ... 1,2 kg/l (only if solar heat balance is enabled)	<b>1,05 kg/l</b>	
13	Fluid heat capacity	2,0 ... 5,0 KJ/kgK (only if solar heat balance is enabled)	<b>3,6 KJ/kgK</b>	
14	Final switch-off temperature	OFF, 90... 210 °C	<b>150°C</b>	
15	Test cycle solar load switch	1 ... 60 Min	<b>10 Min</b>	
16	Switch-over temperature	20...110°C	<b>75°C</b>	

## SOLID FUEL Level (..VV..)

The parameters in this level refer to the special settings for solid fuel application. Enabling occurs only following activation in the *HYDRAULIC* level.

Parameter	Designation	Setting range / Setting values	Factory preset	Individual setting
01	Minimum temperature	20 ... 80 °C	<b>60 °C</b>	
02	Maximum temperature	30 ... 100 °C	<b>90 °C</b>	
03	Switch-on differential	(Switch-off differential +3K) ... 20 K	<b>10 K</b>	
04	Switch-off differential	2 K ... (Switch-on differential - 3K)	<b>5 K</b>	
05	Inhibition heat generator	OFF, 2...180 min	<b>OFF</b>	



## BUFFER Level (..VV..)

The parameters in this level refer to the special settings regarding buffer charging. Enabling occurs only following activation in the *HYDRAULIC* level.

Parameter	Designation	Setting range / Setting values	Factory preset	Individual setting
01	Minimum temperature buffer	5 °C ... Maximum temperature buffer	20 °C	
02	Maximum temperature buffer	Minimum temperature buffer ... 95 °C	80 °C	
03	Temperature excess H-GEN	-10 ... 80 K	8 K	
04	Switching differential	1 ... 70 K	2 K	
05	Forced heat dissipation	OFF 1 Into DHW tank 2 Into heating circuits	OFF	
06	Drain function Switch-on differential	(Switch-off differential + 2 K) ... 30 K	10 K	
07	Drain function Switch-off differential	OFF (Switch-off differential + 2 K) ... 50 K	50 K	
08	Buffer start-up protection	OFF no start-up protection ON start-up protection active	ON	
09	Buffer discharge protection	OFF no discharge protection ON discharge protection active	ON	
10	Buffer operating mode	1 Charging control (heating and DHW) 2 Charging control (heating only) 3 Discharging control (heating and DHW) 4 Discharging control (heating only) 5 Charging control (change over to DHW) 6 Discharging control (to heat generator)	1	
11	Buffer loading pump extended run time	0 ... 60 min.	0 Min.	

## SUMMATION FLOW CONTROL Level

Parameter	Designation	Setting range / Setting values	Factory preset	Individual setting
01	P-band Xp SVLF-control	0,0 ... 50,0 %/K	5 %/K	
02	Sampling time Ta SVLF-control	1 ... 600 sec.	20 sec.	
03	I-band Tn SVLF-control	1 ... 600 sec.	180 sec.	

## CASCADE CONTROL Level

The parameters in this level refer to cascaded heat generators and are only accessible in the first basic unit with data bus address 10.

This level is only available if several heat generators communicate with each other in a data bus connection.

Parameter	Designation	Setting range / Setting values	Factory preset	Individual setting
01	Switching differential	6.0 ... 30 K	<b>8 K</b>	
02	Switching on delay	0...200 min	<b>0 Min</b>	
03	Switching off delay	0...60 min	<b>0 Min</b>	
04	Sequential switch-over power stage sequence	10...100%	<b>65%</b>	
05	Reverse boiler sequence	OFF, 1 ... 250 h	<b>OFF</b>	
06	Leading stage	1...n (stages)	<b>1</b>	
07	Peak load boiler from adress...	OFF 2...(max.stages) all heat generators in cascade numbered	<b>OFF</b>	
08	Changeover basis power at group formation	OFF no changeover ON changeover	<b>OFF</b>	
09	Hot water quick activation	OFF 1... max. number of increments	<b>OFF</b>	

## DATA BUS Level

The parameters in this level refer exclusively to the parameters related to the data bus and they control the access rights to each remote station.

Parameter	Designation	Setting range / Setting values	Factory preset	Individual setting
01	Bus address basic unit	10, 20, 30, 40, 50	<b>10</b>	
02	Bus access room unit HC	1 Advanced access (Owner status) 2 Simple access (Tenant status)	<b>2</b>	
03	Bus access room unit MC1	1 Advanced access (Owner status) 2 Simple access (Tenant status)	<b>2</b>	
04	Bus access room unit MC1	1 Advanced access (Owner status) 2 Simple access (Tenant status)	<b>2</b>	

## RELAY TEST Level

This level allows the check off all relays the controller contains. The relays can be selected with the rotary push-button.

Parameter	Designation	Setting range / Setting values	Factory preset	Individual setting
01	Heat generator test	Different relay sequence according to type of boiler (one or tow level)	OFF	
02	Direct heating circuit pump test	OFF-ON-OFF -...	OFF	
03	Mixing circuit pump 1 test	OFF-ON-OFF -...	OFF	
04	Mixer actuator 1 test	STOP-OPEN-STOP-CLOSE-STOP...	STOP	
05	Mixing circuit pump 2 test	OFF-ON-OFF -...	OFF	
06	Mixer actuator 2 test	STOP-OPEN-STOP-CLOSE-STOP...	STOP	
07	DHW charging pump test	OFF-ON-OFF -...	OFF	
08	Variable output 1 test	OFF-ON-OFF -...	OFF	
09	Variable output 2 test	OFF-ON-OFF -...	OFF	

## ALARM MESSAGE Level

In this level every alarm message that may appear is saved into a message memory stack (max. 20 values)

Parameter	Designation	Setting range / Setting values	Factory preset	Individual setting
01	Alarm message #1	Last alarm message		
02	Alarm message #2	Next to last alarm message		
...	...	...		
20	Alarm message #20	First alarm message		

## ALARM 2 Level (..C..)\*

In this level every alarm message that may appear is saved into a message memory stack (max. 20 values)

Parameter	Designation	Setting range / Setting values	Factory preset	Individual setting
01	Alarm message #1	Last alarm message		
02	Alarm message #2	Next to last alarm message		
...	...	...		
20	Alarm message #20	First alarm message		

\* only in connection with a H-GEN interface and SYSTEM-parameter 28=ON

## SENSOR CALIBRATION Level

In this level all the sensors connected to the control unit can be corrected by  $\pm 5$  K compared to the factory calibration value.

Parameter	Designation	Setting range / Setting values	Factory preset	Individual setting
02	Outdoor sensor	- 5 K ... + 5 K		
03	Heat generator sensor	- 5 K ... + 5 K		
04	Domestic hot water sensor	- 5 K ... + 5 K		
05	Flow sensor mixing circuit 1	- 5 K ... + 5 K		
06	Flow sensor mixing circuit 2	- 5 K ... + 5 K		
07	Solar panel sensor	- 5 K ... + 5 K		
08	Solar buffer sensor	- 5 K ... + 5 K		
09	Variable input 1 (VI 3)	- 5 K ... + 5 K		
10	Variable input 2 (VI 3)	- 5 K ... + 5 K		
11	Variable input 3 (VI 3)	- 5 K ... + 5 K		

## Notes