

## Supplement to the heating specialist instructions

## Operating and installation instructions District heat application

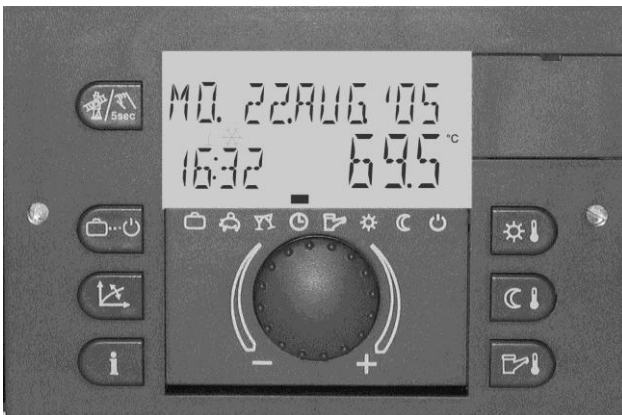

## Content

Electrical connection of the district heating application .....	3
<b>Wall base MS-K .....</b>	<b>4</b>
Terminal assignment.....	5
<b>Heating system information.....</b>	<b>6</b>
Supplementary overview of the specialist parameters and their setting options for the district heating application (version 3.6) .....	7

## Electrical connection of the district heating application

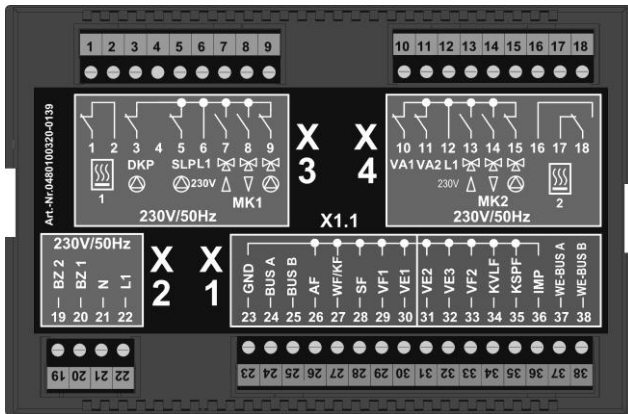

### 230 V $\sim$ Connections

- 1 – District heating valve output CLOSED (Valve control)
- 2 – District heating valve input CLOSED (Control voltage)
- 3 – Pump for direct heating circuit
- 4 – Not connected, used for coding
- 5 – Domestic hot water charging pump
- 6 – L 1 / 230 V $\sim$
- 7 – Mixing valve 1 OPEN
- 8 – Mixing valve 1 CLOSED
- 9 – Pump for mixes heating circuit 1
- 10 – Variable output 1
- 11 – Variable output 2
- 12 – L 1 / 230 V $\sim$
- 13 – Mixing valve 2 OPEN
- 14 – Mixing valve 1 CLOSED
- 15 – Pump for mixes heating circuit 2
- 16 – District heating valve output OPEN (Valve control)
- 17 – Not connected
- 18 – District heating valve input OPEN (Control voltage)
- 19 - Operat. hours counter burner - (Stage 2)
- 20 – Operat. hours counter burner - (Stage 1)
- 21 – N / 230 V $\sim$
- 22 – L 1 / 230 V $\sim$  } mains

### Sensor and data bus connections

- 23 – Ground for data bus and sensors
- 24 – Data bus signal A
- 25 – Data bus signal B
- 26 – Outdoor sensor
- 27 – Sensor heat generator/boiler
- 28 – Domestic hot water sensor
- 29 – Flow sensor for mixed heat. circuit 1
- 30 – Variable input 1
- 31 – Variable input 2
- 32 – Variable input 3
- 33 – Flow sensor for mixed heat. circuit 2
- 34 – Solar panel flow sensor <sup>1)</sup>
- 35 – Solar tank sensor
- 36 – Pulse input
- 37 – Not connected
- 38 – Not connected

### Mounting into boilers

See technical documentation of boiler manufacturer

### Wall mounting

See technical documentation „Wall mounting THETA WG 500“

<sup>1)</sup> Solar application only

## Wall base MS-K



### Application:

The MS-K wall base is used to hold the central unit and is used for wall mounting.

### Version

The wall-mounting base is prepared exclusively for holding the central unit.

The central unit is ready for operation after it has been plugged onto the base board and the outgoing electrical wiring has been completed.

### Assembly and electrical installation

1- Break out the cable glands according to number and size in accordance with the position of the cable duct at the pre-stamped points at the top or bottom.

Note:

If no cable duct is used, must ensure that the cables are suitably relieved.

2- Set the locking screws (1) horizontally and pull the terminal covers off to the side.

3- Mount the wall base on a level surface without distortion using the enclosed screws and dowels. Use the enclosed drilling template.

4- Carry out the electrical wiring according to the system design and the connection diagram overleaf.

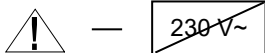

**The connection terminals of the terminal blocks X5 and X6 in the left connection**

**carry safety extra-low voltage and must never come into contact with the mains voltage! Non-observance will inevitably lead to the destruction of the unit and the loss of warranty claims!**

The terminals of the terminal blocks X7 to X10 in the right-hand connection area carry mains voltage depending on the unit version and operating state.

When connecting, press down the operating lever of the screw less terminals before inserting the conductor.

5- Fit and lock the side terminal covers.

6- Insert the central unit and snap it into place under evenly distributed pressure. The electrical connection is made via the socket connectors on the base plate. Lock the central unit in place clockwise with the two quick-clamp devices on the sides.

### Note:

**When wiring the unit, it is essential to ensure that the sensor and data bus cables are laid separately from the mains voltage cables. A common cable routing within a cable is not permissible. If necessary, use cable ducts with separators.**

# Terminal assignment

230V~ connections

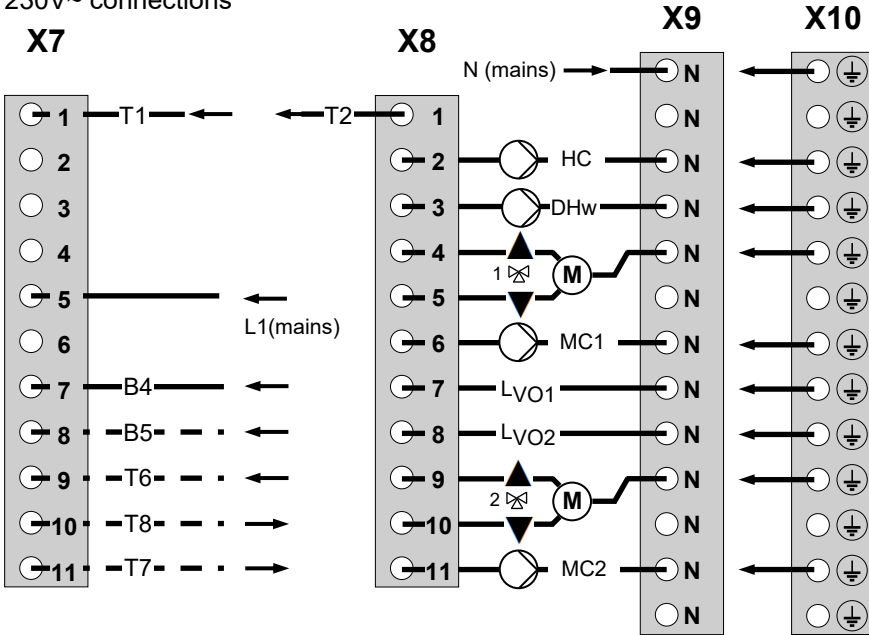

Sensor and data bus connections

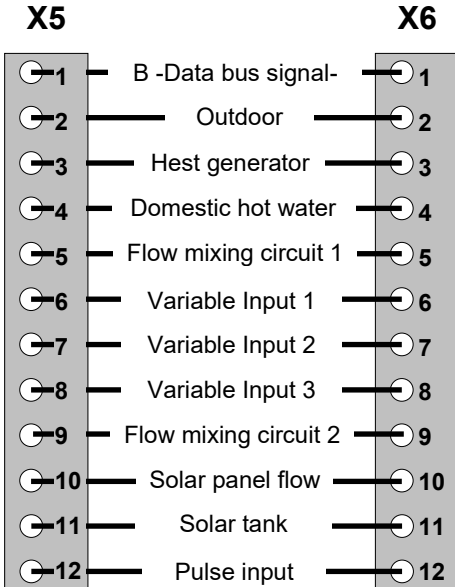

No connection

**District heating connections**

- T1 Control voltage valve CLOSED
- T2 Valve connection Valve CLOSED
- B4 Operating hours counter stage 1
- B5 Operating hours counter stage 2
- T6 Control voltage valve OPEN
- T7 Valve connection Valve OPEN
- T8 No connection
  
- L1 Mains 230 V~ (live)
- N Mains 230 V~ (neutral)

**Pumps and actuators**

- HC Pump for direct heating circuit
- DHW Domestic hot water charging pump
- MC1 Pump for mixed heating circuit 1
- MC2 Pump for mixed heating circuit 2
- 1 M ▲ Actuator mi. valve 1 (OPEN)
- 1 M ▼ Actuator mi. valve 1 (CLOSE)
- 2 M ▲ Actuator mi. valve 2 (OPEN)
- 2 M ▼ Actuator mi. valve 2 (CLOSE)
- Lvo1 Variable Output 1 (live)
- Lvo2 Variable Output 2 (live)

## Heating system information

### Heating system temperatures

After calling up the information level by means of the info key, all existing system temperatures can be called up one after the other by turning the rotary knob clockwise.

If a setpoint is indicated in the table below under the heading Display value,

it will appear when the rotary knob is pressed.

The following displays only appear under the specified display conditions. Some displays are not available according to the respective unit version and are therefore skipped.

INFORMATION	DISPLAY VALUE	DISPLAY CONDITION
Dist. heating HG-FL	Nominal/actual value	District heating programmed
Dist. heating HG-RT	Nominal/actual value	KF 2 connected as HG-RT to a variable input

### Operating states

After calling up the information level by means of the info button, all existing operating states and

acquisition data, such as meter readings, power data, etc., can be queried one after the other by turning the rotary knob anticlockwise.

INFORMATION	Display example	FUNCTION
Status district heating	<i>ACTUATOR DST-H CLOS</i>	Switching status of district heating valve

## Supplementary overview of the specialist parameters and their setting options for the district heating application (version 3.6)

### HYDRAULIC Level

The parameters in this level refer to the general system hydraulics as well as the functionality and configuration of the programmable inputs and outputs for the respective system components. These are not available in room stations!

Parameter	Designation	Setting range / Setting values	Factory setting	Setting
03	Mixing circuit 1 (MC1) output	OFF No Function : 3 Mixing circuit (outdoor temp. contr.) : 40 Constant regulator cooling 50 Pre-mixer layer charge 51 Charging valve ring line	3	
04	Mixing circuit 2 (MC2) output	Setting range and assignment see parameter 03	3	
05	Direct circuit 1 (HC) output	OFF No Function 2 Direct circuit (outdoor temp. contr.) : 41 SHC Switch heating cooling	2	
06	Variable output 1	OFF No Function : 18 Layer charge pump 41 SHC Switch heating cooling	OFF	
07	Variable output 2	Setting range and assignment see parameter 06	OFF	

### District heating application

#### Supplement level MIXER HEATING CIRCLE 1 / MIXER HEATING CIRCLE 2

PARAMETER	Designation	Setting range / Setting values	Factory setting	Setting
14	Temperature rise of heat generator/heating circuits	-5 ... 20 K	MC=4	
21	Valve run time	10...600	120	
39	Temperature spread (DHWV)	1...100 %/K	6	
40	Offset valve position (DHWV)	0...100 %	10	

### District heating level

The parameters in this level refer to the specific control functions of the district heating regulation.

PARAMETER	Designation	Setting range / Setting values	Factory setting	Setting
01	Setpoint increase	AUS, -10,0 ... 50,0 K	0,0	
02	Maximum flow temperature setpoint	10,0 ... 130,0 °C	90,0	
04	Flow temperature amplification	0,1 ... 30,0 %/K	5,0	
05	Sampling time	0 ... 60 min.	3	
06	Running time district heating valve	10 ... 1800 Sec.	120	

## Relay test level

PARAMETER	Designation	Setting range / Setting values	Factory setting	Setting
01	District heating test	STOP-OPEN-STOP-CLOS-STOP-...	STOP	

# WG 500 Anschlussbelegung / Terminal assignment

~~230V~~~

230V~

230V~

230V~

When using the THETA+ N233BHV-FW, please install two jumpers.  
X4-12 to X4-18  
X3-2 to X3-6

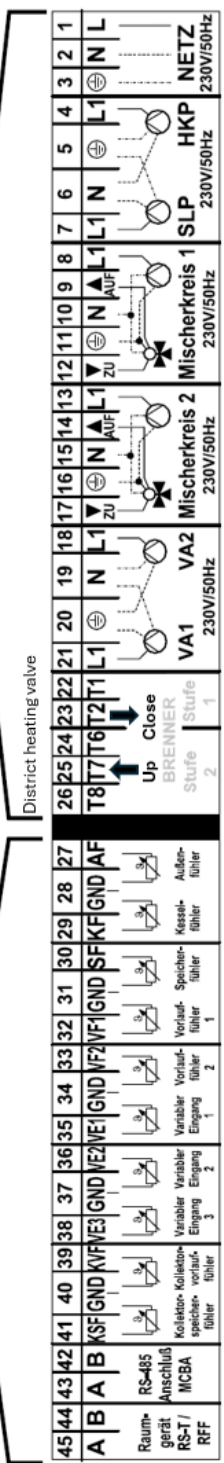
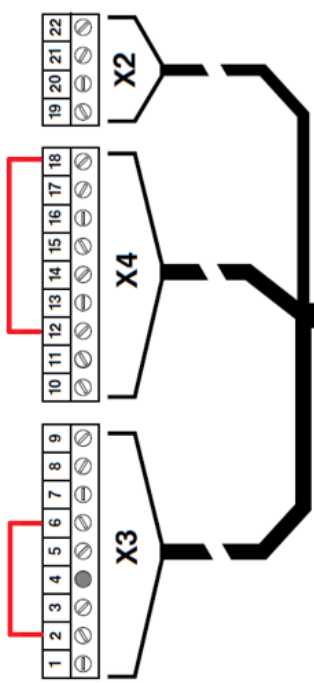

## Note